

# XCSR

## Contactless RFID Safety Switches

### User Manual

Original instructions



# Legal Information

The information provided in this guide contains description of products sold by TMSS France, its subsidiaries and other affiliated companies ('Offer') with technical specifications and technical characteristics of the performance of the corresponding Offer.

The content of this document is subject to revision at any time without notice due to continued progress in methodology, design and manufacturing.

To the extent permitted by applicable law, no responsibility or liability is assumed by TMSS France, its subsidiaries and other affiliated companies for any type of damage arising out of or in connexion with (a) informational content of this guide not conforming with or exceeding the technical specifications, or (b) any error contained in this guide, or (c) any use, decision, act or omission made or taken on the basis of or in reliance on any information contained or referred to in this guide.

**NEITHER TMSS FRANCE, ITS SUBSIDIARIES, NOR ITS OTHER AFFILIATES, AS THE CASE MAYBE, MAKE NO WARRANTY OR REPRESENTATION OF ANY KIND, WHETHER EXPRESS OR IMPLIED, AS TO WHETHER THIS GUIDE OR ANY INFORMATION CONTAINED THEREIN SUCH AS PRODUCTS WILL MEET REQUIREMENTS, EXPECTATIONS OR PURPOSE OF ANY PERSON MAKING USE THEREOF.**

Telemecanique™ Sensors is a trademark of Schneider Electric Industries SAS used under license by TMSS France. Any other brands or trademarks referred to in this guide are property of TMSS France or, as the case may be, of its subsidiaries or other affiliated companies. All other brands are trademarks of their respective owners.

This guide and its content are protected under applicable copyright laws and provided for informative use only.

No part of this guide may be reproduced or transmitted in any form or by any means (electronic, mechanical, photocopying, recording, or otherwise), for any purpose, without the prior written permission of TMSS France. Copyright, intellectual, and all other proprietary rights in the content of this guide (including but not limited to audio, video, text, and photographs) rests with TMSS France, its subsidiaries, and other affiliated companies or its licensors. All rights in such content not expressly granted herein are reserved. No rights of any kind are licensed or assigned or shall otherwise pass to persons accessing this information.

# Table of Contents

Safety Information.....	5
About the Book .....	6
General .....	7
Safety Requirements .....	8
Safety Requirements .....	8
Product Description .....	10
General Information.....	10
XCSR RFID Safety Switch General Description.....	10
How a XCSR RFID Safety Switch Works? .....	11
Operating Zones (Sao – Sar) .....	12
Definition of Characteristic Times .....	13
System Response Time (Process Safety Time) .....	14
Risk Assessment .....	15
XCSR RFID Safety Switch Functions.....	17
Operating Modes .....	17
External Device Monitoring (EDM) or Machine Primary Control Element (MPCE) Monitoring.....	19
Operating and Output States, LED Meaning .....	20
XCSR Standalone Models .....	22
XCSR Daisy-Chain Models for Series Connection.....	23
XCSR Single Models for Point-to-Point Connections .....	26
Pairing Modes.....	28
System Components .....	30
System Components Identification .....	30
XCSR Features.....	31
Installation, Wiring, and Startup.....	32
Installation.....	33
Parts List.....	33
Mounting the XCSR RFID Safety Switch.....	34
Wiring.....	40
Electrical Connections .....	41
Connection Schematics.....	46
Technical Characteristics .....	52
Technical Characteristics .....	52
XCSR RFID Safety Switch Specifications .....	52
Safety Related Data .....	57
Dimensions .....	58
Accessories .....	61
XCSR D210MDB Diagnostic Module.....	64
XCSR D210MDB Diagnostic Module.....	64
Overview.....	64

Description.....	65
Connections Configuration .....	66
Wiring.....	68
Diagnostic LED .....	70
Modbus Registers.....	71
Operating.....	76
Characteristics .....	78
Glossary.....	80

# Safety Information

## Important Information

Read these instructions carefully, and look at the equipment to become familiar with the device before trying to install, operate, service, or maintain it. The following special messages may appear throughout this documentation or on the equipment to warn of potential hazards or to call attention to information that clarifies or simplifies a procedure.



The addition of this symbol to a "Danger" or "Warning" safety label indicates that an electrical hazard exists which will result in personal injury if the instructions are not followed.



This is the safety alert symbol. It is used to alert you to potential personal injury hazards. Obey all safety messages that follow this symbol to avoid possible injury or death.

### **DANGER**

**DANGER** indicates a hazardous situation which, if not avoided, **will result in** death or serious injury.

### **WARNING**

**WARNING** indicates a hazardous situation which, if not avoided, **could result in** death or serious injury.

### **CAUTION**

**CAUTION** indicates a hazardous situation which, if not avoided, **could result in** minor or moderate injury.

### **NOTICE**

**NOTICE** is used to address practices not related to physical injury.

## Please Note

Our product should be installed, operated and maintained only by qualified personnel. Neither TMSS France nor any of its subsidiaries or other affiliated companies shall be responsible or liable for any consequences arising out of the use of this material.

A qualified person is one who has skills and knowledge related to the construction and operation of electrical equipment and its installation, and has received safety training to recognize and avoid the hazards involved.

# About the Book

## Document Scope

This manual describes the features, installation, wiring, usage, and troubleshooting of the XCSR RFID Safety Switches.

## Validity Note

The technical characteristics of the devices described in this manual also appear online. To access this information online:

Step	Action
1	Go to <a href="http://www.telemecaniquesensors.com">www.telemecaniquesensors.com</a> .
2	In the <b>Search</b> box, type the model number of a product or the name of a product range. Do not include blank spaces in the model number/product range.
3	If more than one model number appears in the <b>Products</b> search results, click on the model number that interests you.
4	To save or print a data sheet as a .pdf file, click <b>Download</b> product datasheet.

The characteristics that are described in the present document should be the same as those characteristics that appear online. In line with our policy of constant improvement, we may revise content over time to improve clarity and accuracy. If you see a difference between the document and online information, use the online information as your reference.

## QR Code

A QR code including the Telemecanique Sensors web address is present on the XCSR RFID Safety Switch marking. Technical documents are available in various languages in this website.



## Related Documents

Title of documentation	Reference number
XCSR RFID Safety Switches - Quick Start Guide	NHA77770
XCSR D210MDB Diagnostic module - Quick Start Guide	NHA77776

You can download these technical publications and other technical information from our website at [www.telemecaniquesensors.com](http://www.telemecaniquesensors.com)

## User Comments

We welcome your comments about this document. You can reach us through the customer support page on your local TeSensors website.

# General

## What's in This Part

Safety Requirements .....	8
Product Description .....	10

## Overview

This part provides detailed information about the safety requirements and product description.

# Safety Requirements

## What's in This Chapter

Safety Requirements .....	8
---------------------------	---

## Overview

This chapter describes the safety requirements in detail.

## Safety Requirements

### Precautions

#### **⚠ WARNING**

##### **IMPROPER SETUP OR INSTALLATION**

- This equipment must only be installed and serviced by qualified personnel.
- Read, understand, and follow the compliance below before installing the XCSR RFID Safety Switches.

**Failure to follow these instructions can result in death, serious injury, or equipment damage.**

## Meeting Full Compliance

The compliance of a machine and the XCSR RFID Safety Switches with safety regulations, depends on the proper application, installation, maintenance, and operation of the XCSR RFID Safety Switches. These are responsibilities of the purchaser, installer, and employer.

The employer is responsible for selecting and training the personnel necessary to properly install, operate, and maintain the machine and its safeguarding systems. The XCSR RFID Safety Switches must only be installed, checked, and maintained by a qualified person. A qualified person is defined as “a person or persons who, by possession of a recognized degree or certificate of professional training, or who, by extensive knowledge, training and experience, has successfully demonstrated the ability to solve problems relating to the subject matter and work” (ANSI B30.2).

To use the XCSR RFID Safety Switches, the given requirements must be met:

- The guarded machine must be able to stop anywhere in its cycle.
- The guarded machine must not present metallic chips in the vicinity of the XCSR RFID Safety Switches.
- The guarded machine must have a consistent stopping time and adequate control mechanisms.
- All applicable governmental and local rules, codes, and regulations must be satisfied. This is the user and employer responsibility.
- All safety-related machine control elements must be designed so that an alarm in the control logic or the control circuit breakdown does not lead to a XCSR RFID Safety Switches failure.
- Perform a test of the XCSR RFID Safety Switches during installation and after maintenance or adjustment. As well as in case of any modification of the machine controls, tooling, machine or of the RFID guarding system.

- The proper functioning of the XCSR RFID Safety Switches and its operating line must be checked on a regular basis based on the level of security required by the application (for example, number of operations, level of environmental pollution, ...).
- Perform only the test and diagnostic procedures outlined in this manual.
- Follow all procedures in this manual for proper operation of the XCSR RFID Safety Switches.
- All safety-related machine control circuit elements, including pneumatic, electric, or hydraulic controls must be control-reliable.

The enforcement of these requirements is beyond the control of TMSS France. The employer has the sole responsibility to follow the preceding requirements and any other procedures, conditions, and requirements specific to the machinery.

## Product Support

For more information about products and services in your country, visit [www.telemecaniquesensors.com](http://www.telemecaniquesensors.com).

# Product Description

## What's in This Chapter

General Information .....	10
XCSR RFID Safety Switch Functions .....	17
System Components .....	30

## Overview

This chapter describes the general information, XCSR RFID Safety Switch functions, and system components.

## General Information

### Overview

This section describes general information of the XCSR RFID Safety Switches.

## XCSR RFID Safety Switch General Description

### Overview

The XCSR RFID Safety Switches are used where personnel protection is required. The basic applications are for monitoring the position of movable safety guards to prevent hazardous situations from occurring when the safety guard is opened. Such as, for example:

- Robotic work cells
- Mobile equipments
- Transfer lines
- Assembly lines
- Roll handling equipments
- Automated equipments
- Machine tools
- Food and beverage equipments
- Packaging machines

## How a XCSR RFID Safety Switch Works?

### General Description

A XCSR RFID Safety Switch is a contactless system that consists of a microprocessor-controlled switch (also called "sensor" or "reader") and a transponder (also called "tag" or "coded actuator").

The reader is to be mounted on the fixed part of the safety guard, and the transponder on the mobile part.

There is no contact between the transponder and the switch, a radio-frequency technology is used for the communication.

The reader and the transponder are paired in factory. During the manufacturing, the reader loads into the transponder with which it is sold, a unique code. This saved digital code is the unique "key" accepted by the paired reader.

When the transponder enters the radio frequency field generated by the reader (by closing a guard door for example), the reader detects the transponder and reads the data in the transponder memory.

If the transponder code demanded by the reader is correct, the reader switches its two redundant safety outputs (OSSDs) to the **ON** state, indicating that the safety guard is closed and thus allowing the machine operation. For more details, refer to [XCSR RFID Safety Switch Functions, page 16](#).

When the transponder goes outside the field generated by the reader (by opening a guard door for example) the reader switches its two redundant safety outputs (OSSDs) to the **OFF** state in order to stop the machine, indicating that the safety guard is opened. By the use of a unique coding, RFID technology is robust against tampering (Type 4 - High level of coding - according to ISO 14119).

A transponder cannot be reprogrammed. If for any reason, like a tampering attempt, the reader does not receive from a transponder the only expected code saved in factory, the communication with the transponder is rejected by the reader. The reader then enters in Error mode and switches its safety outputs to the OFF state. A new power-up is then required. XCSR RFID Safety Switch is designed to be compliant with the safety requirements PLe - Cat 4 (ISO 13849-1), SIL3 (IEC 61508) and SILCL3 (IEC 62061).

This illustration presents the XCSR RFID Safety Switch:

- 1 Reader
- 2 Transponder
- 3 Transponder sensitive area
- 4 Reader sensitive area

## Operating Zones (Sao – Sar)

### General Description

When paired transponder and reader are both operating:

- $S_{ao}$  (Assured operating sensing distance) is the distance from the sensing face within which the presence of the specified target is correctly detected under all specified environmental conditions (for example: operating temperature, material of the mounting support) and manufacturing tolerances.
- $S_{ar}$  (Assured release sensing distance) is the distance from the sensing face beyond which the absence of the specified target is correctly detected under all specified environmental conditions (e.g operating temperature, material of the mounting support) and manufacturing tolerances.
- The value of  $S_{ao}$  is the switching distance below which the **ON** state is defined with an absolute certainty (the blue area in the drawing hereunder = OSSDs **ON**)
- The value of  $S_{ar}$  is the switching distance beyond which the **OFF** state is defined with an absolute certainty (the red area in the drawing hereunder = OSSDs **OFF**)
- $S_r$  is the real switch-on sensing distance.

The gray zone represents the “transient state”. Inside the gray area, the commutation points are thus not guaranteed (dispersions zone).

$S_{ao}$  and  $S_{ar}$  values depend on the approach directions and the misalignment between the transponder and the reader (refer to [Mounting and Operating Distances, page 33](#)).

The reader and the transponder parts must be mounted in accordance with the given  $S_{ao}$  and  $S_{ar}$  values to ensure a switch **ON** and a switch **OFF** respectively in the blue ( $<S_{ao}$ ) and red ( $>S_{ar}$ ) areas.

This diagram describes the operating zones:

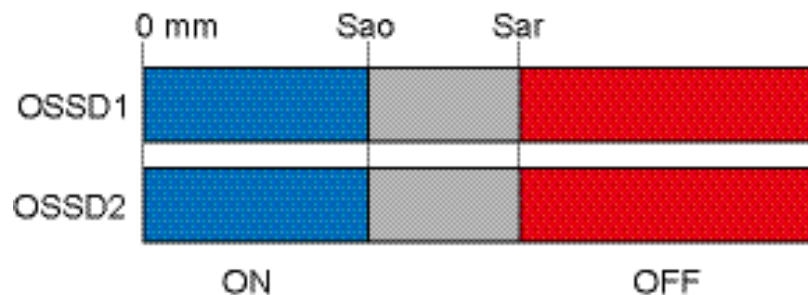

Guaranteed sensing distances for XCSR RFID Safety Switch are given in face to face configuration and without misalignment between the transponder and the reader:

- $S_{ao} = 10 \text{ mm (0.39 in)}$
- $S_{ar} = 35 \text{ mm (1.38 in)}$
- **Hysteresis:**  $3\% \times S_r \leq H_r \leq 20\% \times S_r$

Refer to [face to face mounting configuration, page 36](#).

A slight delay between the switching of the two OSSDs exists and is defined as the [OSSDs Delay Time \(TDT\), page 13](#)

## Definition of Characteristic Times

### Response Time ( $T_t$ )

Time between the transponder is entering the operating zone, and the switching of the OSSDs to the **ON** state. Typical  $T_t = 120$  ms. This time applies for only one reader. In daisy-chain configuration, each additional switch increases this time by 50 ms.

For Standalone models, the typical response time is  $T_t = 250$  ms.

### Risk Time ( $T_r$ )

Time between the transponder is leaving the operating zone, and the switching of the OSSDs to the **OFF** state.  $T_r < 120$  ms. This time applies for only one reader. In daisy-chain configuration, each additional switch increases this time by 18 ms.

### First-up Time ( $T_{ON}$ )

After a power-up, the system is performing self-tests for checking its integrity. The first-up time is the delay, from power-up, after which the system is ready for operation.  $T_{ON} < 5$  s.

### Pairing Mode Time ( $T_{PM}$ )

Time during which a new transponder pairing is possible (for “re-pairing enabled models” only).

$T_{PM} = 10$  s from First-up Time ( $T_{ON}$ ) (10 s after the initialization phase).

### Safety Inputs Inconsistency Time ( $T_{IT}$ )

For daisy-chain configuration, maximum time-out allowed for an inconsistency between the states of the two safety-related inputs. If the time-out is over with a persistent discrepancy, the OSSDs switch to the **OFF** state.  $T_{IT} < 18$  ms.

### OSSDs Delay Time ( $T_{DT}$ )

Defines the time difference between the OSSDs for switching to the OFF state.  $T_{DT} < 18$  ms.

### OSSDs Pulse Time ( $T_{PT}$ )

This time is the width of the periodic pulses generated on each OSSD to perform the monitoring of the safety outputs (short-circuit detection for example). This pulse duration must be compatible with the downstream equipment connected to the OSSDs (safety control unit for example).  $T_{PT} \text{ max} = 1.4$  ms, duty cycle maximum 300 ms.

## System Response Time (Process Safety Time)

### General Description

According to ISO 13855, the total response time (**T**) corresponding to the overall system stopping performance is calculated by the given formula:

$$T = t_1 + t_2$$

Where:

**t1** = Response time of the protection system (in second). It is the total time between the actuation of the safeguard and the switching to the OFF state of its output components. This time corresponds to the "Risk Time" ( $T_r$ )

**t2** = Stopping time of the machine (in seconds): maximum time required to terminate the hazardous machine function after the output signal from the safeguard achieves the OFF-state. This information is supplied by the machine manufacturer. The response time of the control and the output systems of the machine is included in **t2**.

#### **WARNING**

##### **IMPROPER SETUP**

- Ensure that the XCSR RFID Safety Switch is mounted far enough away from the operations hazard to fully accommodate the stopping time.
- When using a safety control unit like safety relays or controllers, the response time of the safety control unit must be added to the overall system stopping time.

**Failure to follow these instructions can result in death, serious injury, or equipment damage.**

# Risk Assessment

## General Description

Risk assessment and risk reduction are **iterative processes** described in ISO 12100, IEC 61508 & IEC 62061 (SIL and SILCL), and ISO 13849-1 (PL). There are various techniques for risk assessment, and not one of it can be considered as the right way to perform risk assessment. The standard specifies some general principles but does not specify exactly what has to be done in each case.

For safety-related data, refer to [Safety Related Data](#) section, page 57.

This flowchart describes the risk assessment process:

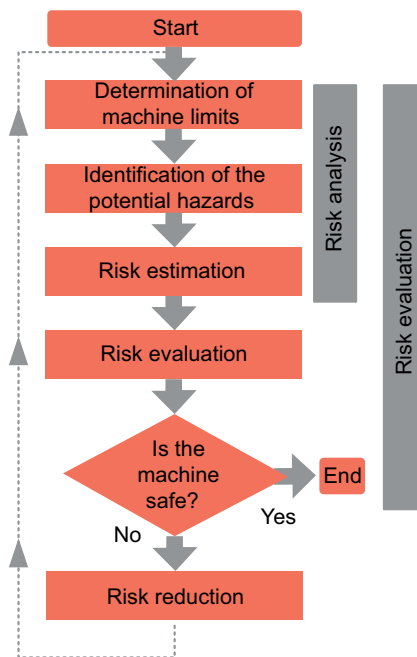

Essential steps for risk assessment are the following:

- Define tolerable risk level.
- Identify hazards.
- Analyze hazards.
- Determine whether the risks are below an acceptable level.
- Define protection measures if risks are above a tolerable level.
- Check whether protection measures taken lead to an effective risk reduction (Iterative process).

This figure describes the elements of risk to take into account for the risk estimation:

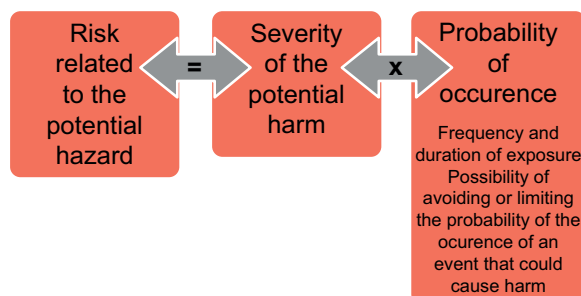

**⚠ WARNING****IMPROPER TYPE UTILIZATION**

It is the responsibility of the user or integrator to check whether the use of the XCSR RFID Safety Switch is consistent with the application risk assessment. To choose the right product for your application, perform a risk assessment.

**Failure to follow these instructions can result in death, serious injury, or equipment damage.**

For more information, refer to: [www.se.com/uk/en/download/document/DIA4ED1100102EN/](http://www.se.com/uk/en/download/document/DIA4ED1100102EN/).

## Reference Standards

The following table describes the main reference standards:

Standard	Risk assessment	Description
ISO 12100	Risk assessment and risk reduction	Safety of machinery.General principles for design.Risk assessment and risk reduction.
Standard	Safety level	Description
ISO 13849-1	Performance level (PL)	Safety-related part of control system.General principles for design.
	Category (Cat)	
IEC 61508	Safety integrity level (SIL)	Functional safety of electrical/electronic/programmable electronic safety-related systems.
IEC 62061	Safety integrity level claim limit (SILCL)	Safety of machinery.Functional safety of safety-related electrical, electronic, and programmable electronic control systems.
Standard	Type-B standards	Description
ISO 14119	Safeguards(interlocking devices)	Safety of machinery.Interlocking devices associated with guards.Principles for design and selection.
IEC 60947-5-2	Low-voltage switchgear and controlgear	Control circuit devices and switching elements. Proximity switches.
IEC 60947-5-3	Low-voltage switchgear and controlgear	Control circuit devices and switching elements. Requirements for proximity devices with defined behavior under fault found conditions (PDDB).

# XCSR RFID Safety Switch Functions

## Overview

This section describes the various functions of XCSR RFID Safety Switch.

## Operating Modes

### Introduction

The operating mode determines the start-up and operating behavior of the XCSR RFID Safety Switch. The operating mode descriptions in this section are derived from the operating state [definitions, page 20](#).

### Automatic Start

In this mode, the system enters the **Run** state after startup without operator intervention, as long as the paired transponder is in the reader detection zone. When the XCSR RFID Safety Switch is powered up, it enters the initialization phase during which its safety outputs are **OFF**. If no faults are detected and the safety guard is closed, it enters the [Run state, page 20](#) after 5 seconds maximum (refer to  $T_{ON}$  [First-up Time, page 13](#)) and the two safety outputs switch to **ON** state. In this state, when the transponder leaves the operating zone (safety guard opening), the XCSR RFID Safety Switch changes from **RUN** state to [stop state, page 20](#) (the two safety outputs switch to **OFF** state), and remains in the **Stop** state until the paired transponder enters again the detection zone (without any fault detected): the XCSR RFID Safety Switch then automatically changes from **Stop** state to **Run** state and the two safety outputs switch to **ON** state.

Automatic Start is available on XCSRC•1AM12 standalone models

#### **WARNING**

##### **IMPROPER SETUP OR INSTALLATION**

The manual Start/Restart is required in most safety applications. If you use the automatic start function, check that this automatic start mode is compatible with risk assessment performed for the application.

**Failure to follow these instructions can result in death, serious injury, or equipment damage.**

### Manual Start/Restart

When the XCSR RFID Safety Switch is powered up, it enters the initialization phase during which its safety outputs are **OFF**. If no faults are detected after the first-up time, it enters the Start/Restart state. To enter the **Run** state and switch the OSSDs to **ON**, the paired transponder must be in the reader detection zone, no faults detected, and the operator must press and release ("monitored start") the **Start** button. Then, if the XCSR RFID Safety Switch leaves the detection zone when it is in **Run** state, the XCSR RFID Safety Switch changes to **Stop** state and the safety outputs change from **ON** to **OFF** state.

If the paired transponder enters the detection zone again (and no faults are detected), the safety outputs stay at the **OFF** state until the push button is actuated.

**⚠ WARNING****UNINTENDED EQUIPMENT OPERATION**

- Follow the requirements concerning start/restart operating modes defined in ISO 12100: "Requirements for interlocking guards with a start function (control guards)" section.
- The Restart command must be installed outside the hazardous area in such way that the whole working and hazardous areas are observable. You must not access the Start/Restart command inside the hazardous area.

**Failure to follow these instructions can result in death, serious injury, or equipment damage.**

**NOTICE****UNINTENDED EQUIPMENT OPERATION**

- For «monitored manual Start/Restart», the command is effective after the operator has pressed and released the Start button, which means a transition sequence 0 Vdc → 24 Vdc → 0 Vdc on the start command. The minimum duration of this sequence must be between 200 ms and 5 s. Beyond the 5 s, the release action on the command will not activate the XCSR RFID Safety Switch. The operator will have to repeat the start/restart sequence and release the command before 5 s.
- The «monitored manual Start/Restart» is available exclusively on XCSRC•1MM12 standalone models.
- For Single and Daisy-Chain XCSR RFID Safety Switch models, refer to the safety control unit operating instructions

**Failure to follow these instructions can result in equipment damage.**

## External Device Monitoring (EDM) or Machine Primary Control Element (MPCE) Monitoring

### General Description

EDM monitoring is an important safety function.

The EDM monitors the interface between XCSR RFID Safety Switch and the guarded machine to:

- Confirm that the external devices such as switching devices like contactors are responding correctly to the XCSR safety outputs.
- Detect any inconsistency between the two external devices (that is, control relays or contactors) which could prevent a stop signal from reaching the machine primary control elements (for example, power contactors or electrovalve relays).

The EDM controls the external contactors KM1/KM2 connected to the two OSSDs.

To achieve this, normally closed contacts of the external contactors are monitored.

To perform this function, the contactors KM1/KM2 must have:

- Normally closed mirror contact, according to IEC 60947-4-1 (Annex F) for power contactors.
- Linked contacts (or force-guided contacts), according to IEC 60947-5-1 (Annex L) or IEC 61810-3 for auxiliary contactors or control relays.

XCSR RFID Safety Switch standalone models have built-in EDM function. For Daisy-Chain and Single models, refer to the safety control unit operating instructions (e.g safety relay or safety controller).

To manage the EDM function, refer to [wiring instructions, page 44](#).

## Operating and Output States, LED Meaning

### Introduction

This figure describes the diagnostic LED of the XCSR reader:

**LED 1 (TR)** Transponder state

**LED 2 (RD)** Reader/Output state

### Diagnostic LED Meanings

This table describes the operating and output states with LED meanings and output states of the XCSR RFID Safety Switch:

Operating state	LED 1 Transponder	LED 2 Reader	OSSDs	LEDs meaning	Comment
OFF	OFF	OFF	OFF	XCSR reader is unpowered	-
Initialization	Orange	Orange	OFF	XCSR reader initialization in progress	-
Configuration	Orange Fast blinking	Orange Fast blinking	OFF	XCSR reader is in configuration mode	-
	Green	Orange Fast blinking	OFF	Pairing with new transponder done: new power-up required	Only for "re-pairing enabled models"
	Orange Blinking	Red	OFF	Maximum of pairing reached	-
	Red Blinking	Red	OFF	Invalid transponder detected	Transponder not blank or not Telemecanique transponder
	Orange Fast blinking	Red	OFF	Pairing process unsuccessful	Only for "re-pairing enabled models"
Run	Green	Orange Blinking	OFF	Paired transponder detected: waiting for the start condition and/ or KM1_KM2 feedback (EDM)	Only for standalone versions
	Green	Green	ON	Paired transponder detected and all other operating conditions are correct	Door closed
	Green	Red	OFF	Paired transponder detected but the safety inputs are at the OFF state.	For Daisy-Chain models: at least one of the previous readers has its OSSDs at the OFF state (door opened, error detected or OFF state)
	OFF	Red	OFF	No transponder in the field	Door opened

Operating state	LED 1 Transponder	LED 2 Reader	OSSDs	LEDs meaning	Comment
Error detected	Red Blinking	Red Blinking	OFF	Invalid transponder or non-paired transponder detected: new power-up required after fault clearance	Possible attempted fraud or transponder damaged
	Green or OFF	1, 2, 3, 4 or 5 red flashes	OFF	Internal error detected. Contact the customer support of your country.	The color of the LED 1 depends on the presence of the transponder: Green: transponder detected OFF: no transponder detected

**NOTE :** The safe state is ensured when the two redundant safety outputs (OSSDs) are switched at the OFF state (for example: guard door opened or safety switch in error mode).

## XCSR Standalone Models

### General Description

Special models of the XCSR RFID Safety Switches (XCSRC•1•M12) are designed to be used as standalone products, when associated with contactors having mechanically linked contacts (force-guided) connected to the OSSDs that is, without any safety relay, controller, or PLC. In standalone operation, the two OSSDs are connected directly to the contactors. This connection is made through a pre-wired 8 pins M12 connector.

Refer to [Connection Schematics, page 46](#).

1 XCSRC•1MM12: XCSR RFID Safety Switch standalone model

2 KM1: contactor 1 - OSSD1

3 KM2: contactor 2 - OSSD2

#### **⚠ WARNING**

##### **IMPROPERD EQUIPMENT OPERATION**

The KM1 and KM2 contactors must have [force-guided contacts, page 19](#).

**Failure to follow these instructions can result in death, serious injury, or equipment damage.**

#### **NOTICE**

##### **UNINTENDED EQUIPMENT OPERATION**

Use of arc suppressors for KM1 & KM2 is recommended.

**Failure to follow these instructions can result in equipment damage.**

## Features and Requirements

The XCSR RFID Safety Switch standalone models have the given features and requirements:

- 2 OSSDs
- External Device Monitoring (EDM) (selected by wiring)
- Start feature:
  - Monitored manual Start/Restart: XCSR•1MM12
  - Automatic Start: XCSR•1AM12

XCSRC•1•M12 standalone models are compliant with the following safety standards SIL3 (IEC 61508) SILCL3 (IEC 62061), and PLe- Cat.4 (ISO 13849-1)

It is the aim of the risk analysis to determine whether the use of XCSRC•1•M12 standalone models are compatible with the expected safety integrity level of the entire system.

#### **⚠ WARNING**

##### **IMPROPER UTILIZATION**

It is the responsibility of the user or integrator to check whether the use of standalone XCSR RFID Safety Switch is consistent with the application risk assessment. Perform a risk assessment to choose the right product for your application.

**Failure to follow these instructions can result in death, serious injury, or equipment damage.**

# XCSR Daisy-Chain Models for Series Connection

## General Description

XCSRC•2M12 models of XCSR RFID Safety Switches can be connected in series. The daisy-chain function allows multiple safety guards to be connected in series.

Thanks to their integrated connection means, the readers can be easily wired without using additional "T" or "Y" connectors. These connection means are two M12 5 pins male connectors (a reader by-pass is less easy to operate than if it was male/female connectors).

A direct connection between the XCSR readers can thus be made by using female/female M12 5 pins cables (see [cable references, page 62](#)).

Refer to [Connection Schematics, page 46](#).

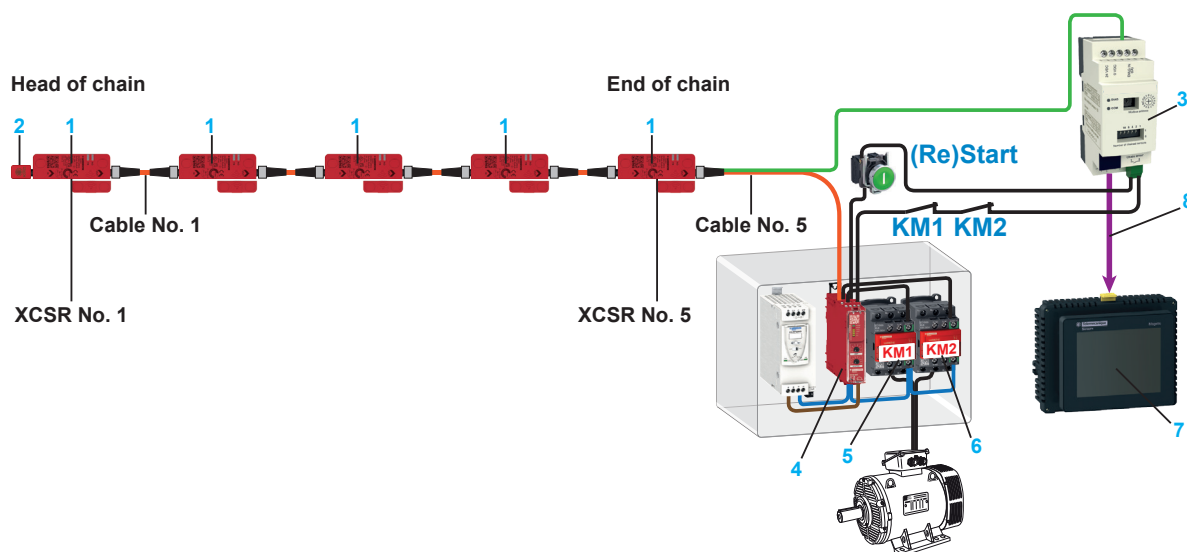

- 1 XCSRC•2M12: XCSR RFID Safety Switch Daisy-Chain model
- 2 XCSRZE: Loopback device
- 3 XCSR D210MDB: Diagnostic module
- 4 XPSUAK•••: Safety relay
- 5 KM1: contactor 1 - OSSD1
- 6 KM2: contactor 2 - OSSD2
- 7 HMI
- 8 VW3A8306R••: 2xRJ45 Modbus cable

<b>⚠ WARNING</b>
<b>UNINTENDED EQUIPMENT OPERATION</b>
The KM1 and KM2 contactors must have <a href="#">force-guided contacts, page 22</a> .
<b>Failure to follow these instructions can result in death, serious injury, or equipment damage.</b>

## Features and Requirements

Daisy-chain XCSRC•2M12 models have the given features and requirements:

- 2 OSSDs.
- Up to 20 XCSRC•2M12 can be connected in series.
- Up to 5 XCSRC•2M12 connected in series, the maximum length between each XCSRC•2M12 is 30 m (98.4 ft.).

For higher numbers of XCSRC•2M12, the maximum cable length allowed between each XCSRC•2M12 decreases. For example, for 10 XCSRC•2M12 connected in series, the maximum length between each XCSRC•2M12 is 10 m (32.8 ft.).

- The association with a safety control unit (safety relay or controller for example) is mandatory.
- External Device Monitoring (EDM) and Start/Restart conditions to be managed by a safety control unit.
- A M12 plug (XCSRZE) must be connected to the reader which starts the chain (loopback device).
- Recommended diagnosis of the chain status with the XCSR210MDB [diagnostic module, page 64](#).

### WARNING

#### IMPROPER CONNECTION

The safety inputs of the safety control unit must be suitable to XCSR OSSDs pulsed signals specified in [XCSR RFID Safety Switch specification - Characteristics Time, page 53](#).

**Failure to follow these instructions can result in death, serious injury, or equipment damage.**

### WARNING

#### IMPROPER CONNECTION

The diagnostic module, every XCSRC•2M12, and the safety control unit must be powered by the same power supply.

**Failure to follow these instructions can result in death, serious injury, or equipment damage.**

Daisy-chain models XCSRC•2M12 are compliant with the following safety standards:

- SIL3 (IEC 61508) SILCL3 (IEC 62061), and PLe- Cat.4 (ISO 13849-1)
- The overall safety integrity level of the system must consider the number of XCSRC•2M12 switches connected in series but also the reliability data of the signal processing unit and the output system.



According to ISO 13849-1 and IEC 62061, the  $PFH_D$  corresponding to a SIL3 integrity level of a safety function must be within the following limits:

$$10^{-7} \geq PFH_D \geq 10^{-8}$$

$PFH_D$  = average probability of dangerous failure per hour for high demand or continuous mode of operation

The contribution to the total  $PFH_D$  of the switches, the signal processing unit, and the output system depends on the reliability data of the devices used in the application.

An example of PFH<sub>D</sub> contribution of an entire safety function is given below:

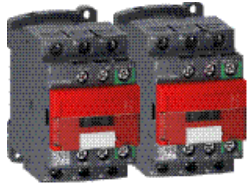
XCSR**	XPSUAF1***	TeSys redundant contactor:
PFH <sub>D</sub> = 5x10 <sup>-10</sup> per switch	PFH <sub>D</sub> = 1.13x10 <sup>-9</sup>	PFH <sub>D</sub> = 24.7x10 <sup>-9</sup>
		
Switches	Logic Treatment	Pre-actuators/Actuators

Theoretical maximum number of switches connectable in series

In this example, the maximum PFH<sub>D</sub> allowed for the series connection is:

$$[PFH_{D_{max}}] \text{ switches} = 1 \times 10^{-7} - 1.13 \times 10^{-9} - 24.7 \times 10^{-9} = 74.17 \times 10^{-9}$$

The PFH<sub>D</sub> of one XCSR RFID Safety Switch is 5x10<sup>-10</sup>, it means that the **theoretical** maximum number of XCSR RFID Safety Switch that could be connected in series, without impacting the overall safety level (SIL3-PLe) would be

$$N_{max} = 74.17 \times 10^{-9} / 5 \times 10^{-10} = 148$$

Thus, the maximum number of chainable switches will be more limited by electrical constraints

**Practical maximum number of switches connectable in series**

In practice, by considering a realistic number of switches which could be connected in series as well as electrical limitations, the maximum number of XCSR RFID Safety Switch that can be connected in series has been limited to 20.

<b>⚠ WARNING</b>
<p><b>UNINTENDED EQUIPMENT OPERATION</b></p> <p>The maximum number of switches that can be connected in series depends on different factors:</p> <ul style="list-style-type: none"> <li>• The overall safety integrity level expected for the application.</li> <li>• The cable length between each XCSR reader,</li> <li>• The output current,</li> <li>• The input voltage,</li> <li>• The wire cross section (see <a href="#">Electrical Connections, page 41</a>).</li> </ul> <p><b>Failure to follow these instructions can result in death, serious injury, or equipment damage.</b></p>

<b>⚠ WARNING</b>
<p><b>IMPROPER UTILIZATION</b></p> <p>It is the responsibility of the user or integrator to check whether the use of daisy-chain XCSR RFID Safety Switch is consistent with the application risk assessment. Perform a risk assessment to choose the right product for your application.</p> <p><b>Failure to follow these instructions can result in death, serious injury, or equipment damage.</b></p>

## XCSR Single Models for Point-to-Point Connections

### General Description

XCSRC•0M12 references are suitable for monitoring multiple safeguards by point-to-point connections to a safety control unit (safety controller or safety PLC for example).

Refer to [Connection Schematics](#), page 46.

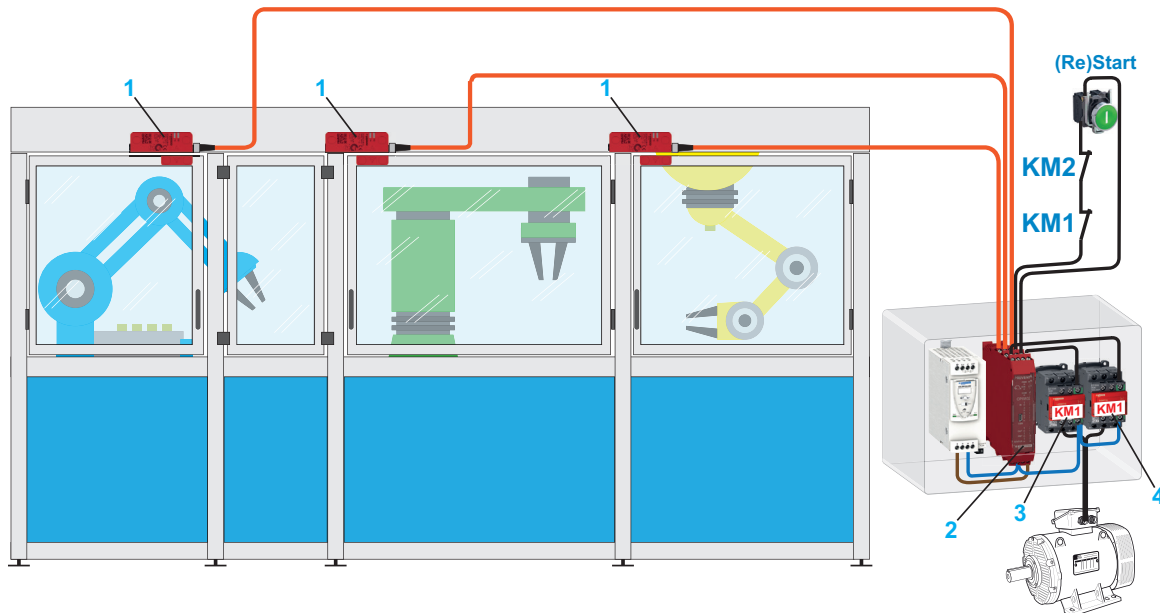

- 1 XCSRC•0M12: XCSR RFID Safety Switch single model
- 2 XPSMCMCP0802: safety controller
- 3 KM1: contactor 1 - OSSD1
- 4 KM2: contactor 2 - OSSD2

The association of the XCSR readers is, in this case, made by software at the safety control unit level.

### ⚠ WARNING

#### UNINTENDED EQUIPMENT OPERATION

The KM1 and KM2 contactors must have [force-guided contacts](#), page 19.

**Failure to follow these instructions can result in death, serious injury, or equipment damage.**

### Features and Requirements

Single XCSRC•0M12 models have the given features and requirements:

- 2 OSSDs.
- The association with a safety control unit (safety controller for example) is mandatory.
- The External Device Monitoring (EDM) and Start/Restart conditions must be managed by a safety control unit.

**⚠ WARNING****IMPROPER CONNECTION**

The safety inputs of the safety control unit must be suitable to XCSR OSSDs pulsed signals specified in [XCSR RFID Safety Switch specification - Characteristics Time, page 53](#) .

**Failure to follow these instructions can result in death, serious injury, or equipment damage.**

Single models XCSRC•0M12 are compliant with the following safety standards:

- SIL3 (IEC 61508) SILCL3 (IEC 62061), and PLe- Cat.4 (ISO 13849-1)
- The overall safety integrity level of the system must consider the configuration of XCSRC•0M12 switches connected but also the reliability data of the signal processing unit and the output system.

It is the aim of the risk analysis to determine whether the use of single models XCSRC•0M12 are compatible with the expected safety integrity level of the entire system.

**⚠ WARNING****IMPROPER UTILIZATION**

It is the responsibility of the user or integrator to check whether the use of single XCSR RFID Safety Switch is consistent with the application risk assessment. Perform a risk assessment to choose the right product for your application.

**Failure to follow these instructions can result in death, serious injury, or equipment damage.**

## Pairing Modes

### General Description

For every model (standalone, daisy-chain and single), two references corresponding to two different pairing modes are available:

- **XCSRC1•M12** “Unique pairing” models: **Unique Code, digital code saved in factory. New transponder pairing is impossible.**  
In case of transponder damage, the transponder and the reader must be both replaced.
- **XCSRC3•M12** “re-pairing enabled” models: **Unique Code, digital code saved in factory. Two new (blank) transponder pairings are possible (and only two).**

In case of transponder damage, a new blank transponder can be paired by the reader within a limit of two new transponder pairings. Blank transponders are available as spare parts (XCSRK2A3).

A new transponder pairing removes definitely the previous code saved in the reader. The previous transponder is thus no longer usable.

The transponder pairing is an automatic procedure initialized at the power-up phase.

The pairing mode (configuration state) is available during 10 s after the initialization phase.

**NOTE:** A transponder is paired only one single time and can never be reprogrammed.

#### Pairing procedure for XCSRC3•M12 models:

During the 10 s following the initialization phase, a blank transponder XCSRK2A3 must be placed in the detection zone (at a distance  $\leq S_{ao}$ , see NOTICE below) and the new pairing will be automatically performed. The previous transponder data are removed from the reader memory. A new power-up is then required.

The new transponder pairing will be rejected in the following cases:

- Transponder not blank
- Transponder blank but wrong ID
- Transponder correct but number of pairings memorized by the reader  $\geq 2$
- The reader is a unique pairing reference (**XCSRC1•M12**)

### **NOTICE**

#### **UNINTENDED EQUIPMENT OPERATION**

- For a new pairing operation, the transponder must be placed and maintained at a distance  $\leq S_{ao}$ , without misalignment with the reader, until the end of the pairing operation.
- During a transponder pairing process, do not place other transponder in the detection area.

**Failure to follow these instructions can result in equipment damage.**

**⚠ WARNING**

**UNINTENDED EQUIPMENT OPERATION**

- The possibility to pair up to two new blank transponders, provides flexibility in case of transponder damages. However, the integrity of the safety system is reduced due to the availability of actuators as spare parts which could increase the possibilities of tampering.
- Strict procedures must be implemented in order to control the access to these blank transponders and to their use.

**Failure to follow these instructions can result in death, serious injury, or equipment damage.**

## Pairing number

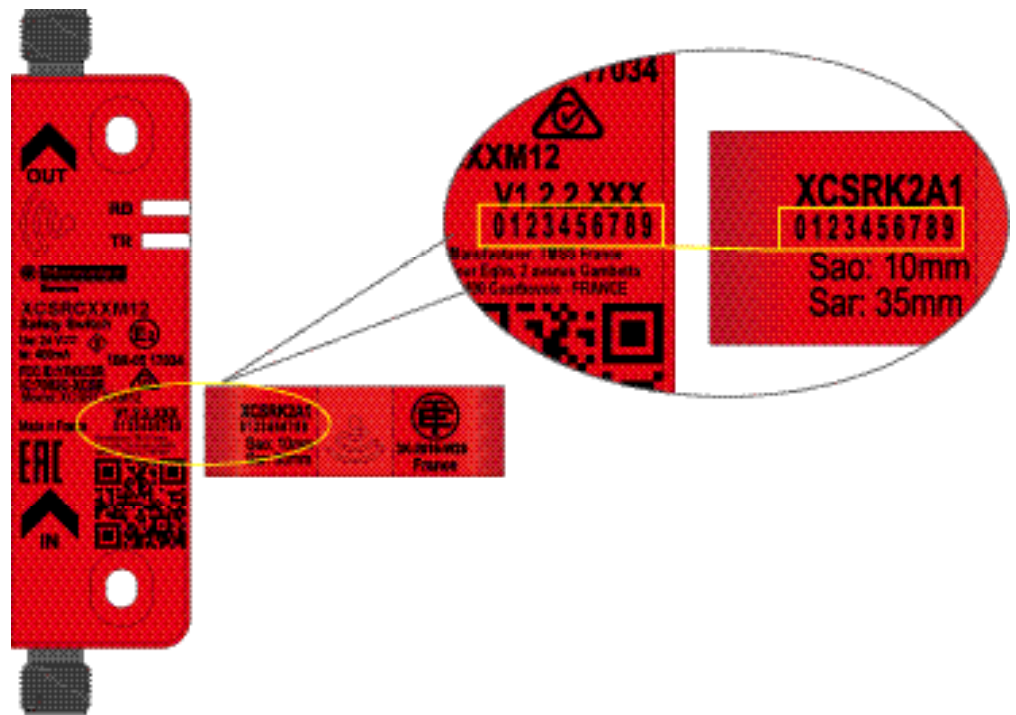

**NOTE:** During the factory pairing phase, a same traceability number is printed on both parts (transponder and reader).

# System Components

## Overview

This section describes the system components and the main features of the XCSR RFID Safety Switches.

## System Components Identification

### General Description

This figure displays the system components:

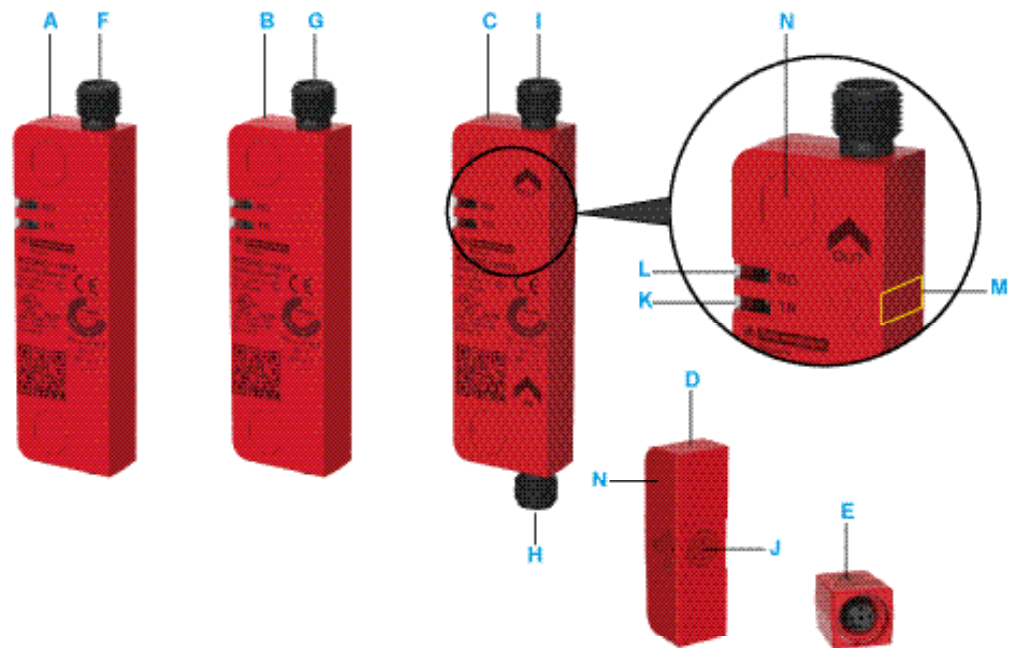

This table describes the system components:

Component	Description	Component	Description
A	XCSRC•0M12: Single	F	M12 5 pins male connector
B	XCSRC•1•M12: Standalone	G	M12 8 pins male connector
C	XCSRC•2M12: Daisy-chain	H, I	M12 5 pins male connector
D	Transponder	J	Transponder sensitive area
E	Loopback device M12	M	Reader sensitive area
K	Visualization of transponder state	N	Blanking plugs
L	Visualization of reader state		

## XCSR Features

Features This table describes the main standard features of XCSR RFID Safety Switches:

Features	XCSRC•-0M12	XCSRC•1•-M12	XCSRC•-2M12
	Single	Standalone	Daisy-chain
Two PNP safety outputs (OSSDs)	✓	✓	✓
Automatic start/restart	–	XCSRC•1A-M12	–
Monitored manual start	–	XCSRC•1M-M12	–
External Device Monitoring (EDM) feedback input	–	✓	–
EDM & Automatic/manual start/restart through safety control unit	✓	–	✓
Transponder with rotating sensitive face	✓	✓	✓
Direct series connection (daisy-chain)	–	–	✓
Point-to-point connection to a safety control unit	✓	–	–
Chain diagnosis through XCSR D210MDB diagnostic module	–	–	✓
LED indicators for status and diagnosis	✓	✓	✓
Non-shielded M12 pre-wired <a href="#">cables, page 62</a> (to be ordered separately)	✓	✓	✓
References for unique code - Unique pairing	XCSRC10-M12	XCSRC11•-M12	XCSRC12-M12
References for unique code - two new transponder pairings possible	XCSRC30-M12	XCSRC31*-M12	XCSRC32-M12
✓ indicates feature availability in the corresponding XCSR RFID Safety Switch model.			

# Installation, Wiring, and Startup

## What's in This Part

Installation..... 33  
 Wiring..... 40

## Overview

This section provides information about installation, wiring, and startup.

<b>⚠ WARNING</b>
<p><b>IMPROPER SETUP</b></p> <ul style="list-style-type: none"> <li>• Read the information in this section completely before starting the <a href="#">installation procedures, page 33</a>.</li> <li>• The XCSR RFID Safety Switch must be installed, checked, and maintained by qualified personnel as defined in the <a href="#">Meeting Full Compliance, page 8</a>.</li> <li>• The user must be familiar with the installation requirements, system controls, and features before using the XCSR RFID Safety Switch.</li> </ul> <p><b>Failure to follow these instructions can result in death, serious injury, or equipment damage.</b></p>

<b>⚠ WARNING</b>
<p><b>UNINTENDED EQUIPMENT OPERATION</b></p> <ul style="list-style-type: none"> <li>• Check the correct operation of the XCSR RFID Safety Switch at power-up phases and before each shift.</li> <li>• Presence of metallic chips (even small) in the vicinity of the XCSR RFID Safety Switch can modify the sensing distance.</li> </ul> <p><b>Failure to follow these instructions can result in death, serious injury, or equipment damage.</b></p>

# Installation

## What's in This Chapter

Parts List..... 33  
 Mounting the XCSR RFID Safety Switch..... 34

## Overview

This chapter describes the installation of the XCSR RFID Safety Switches.

## Parts List

### Parts

This figure displays the different parts of the XCSR RFID Safety Switch:

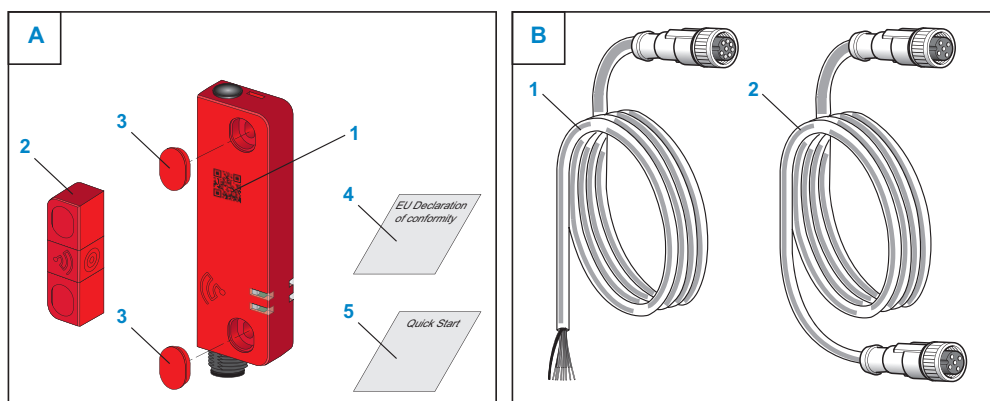

**A.** The XCSR RFID Safety Switch package includes:

1. XCSR Reader (paired in factory) with [QR Code, page 6](#)
2. XCSR Transponder (paired in factory)
3. 4 x Blanking plugs
4. EU Declaration of conformity
5. Quick start guide

**B.** M12 pre-wired [connection cables, page 62](#) (to be ordered separately):

1. Reader connection cable: female M12 5 or 8 pins pre-wired
2. Reader interconnections (daisy-chain): female/female M12 5 pins

## Mounting the XCSR RFID Safety Switch

### Overview

#### ⚠ WARNING

##### UNINTENDED EQUIPMENT OPERATION

- The operating distances depend on the approach direction.
- Before mounting the XCSR RFID Safety Switch, refer to this section.

**Failure to follow these instructions can result in death, serious injury, or equipment damage.**

### Mounting

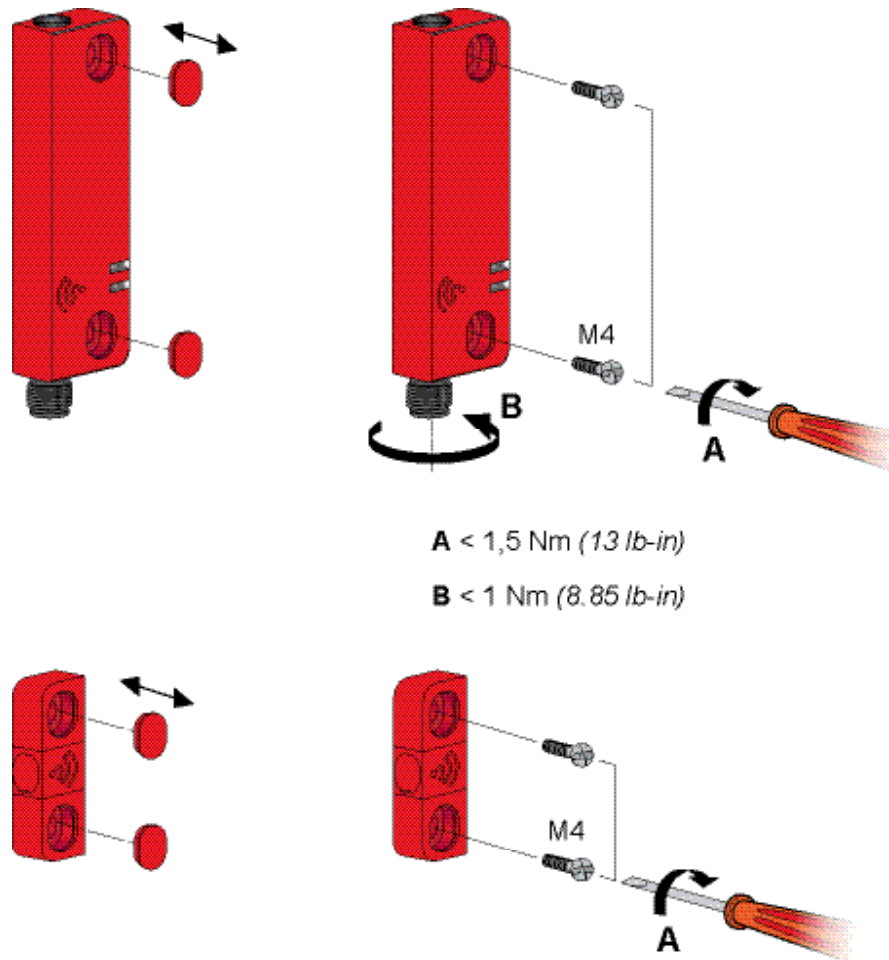

**NOTE:** To prevent unauthorized removal of the reader and/or the transponder, one-way screws are available as [Accessories, page 60](#).

## Multiple Systems

In case of applications requiring multiple readers which are mounted in close proximity, a minimum distance between readers must be respected to avoid mutual interferences:

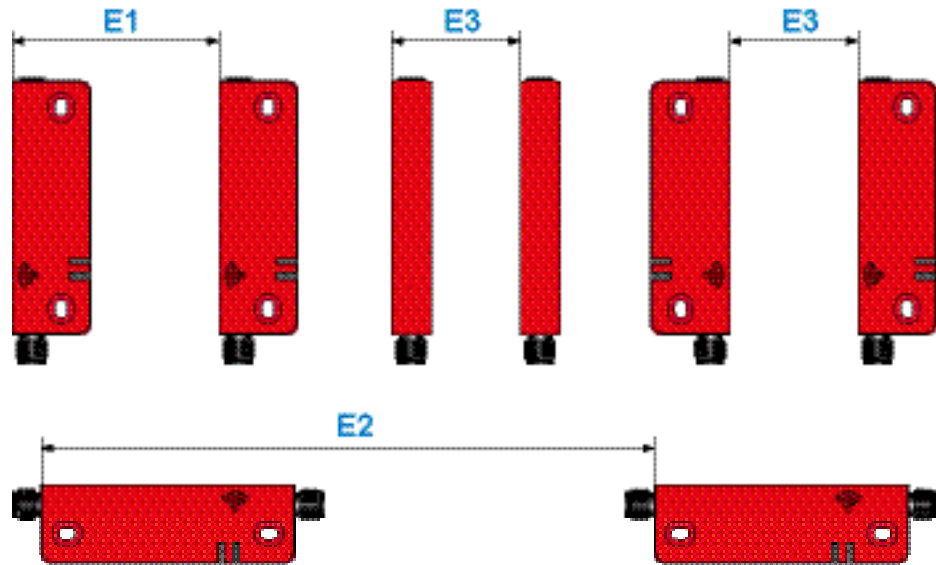

$$E1_{\min} = 120 \text{ mm} / 4.72 \text{ in}$$

$$E2_{\min} = 160 \text{ mm} / 6.30 \text{ in}$$

$$E3_{\min} = 120 \text{ mm} / 4.72 \text{ in}$$

## Functional Directions

Different allowed approach directions and associated detection curves are given below.

<b>⚠ WARNING</b>
<p><b>UNINTENDED EQUIPMENT OPERATION</b></p> <ul style="list-style-type: none"> <li>• Typical switch-on and switch-off values are given for information only, and with a non-magnetic material support for the transponder and the reader. These typical values may vary depending on the support materials used.</li> <li>• The XCSR RFID Safety Switch must always be mounted and used with respect to the assured sensing distances <math>S_{ao}</math> and <math>S_{ar}</math>. When the guard is closed, the maximum distance between the transponder and the reader must be <math>S_{ao}</math>. When the guard is being opened and up to <math>S_{ar}</math>, the protected machinery shall not present any risk of danger.</li> </ul> <p><b>Failure to follow these instructions can result in death, serious injury, or equipment damage.</b></p>

<b>⚠ WARNING</b>
<p><b>UNINTENDED EQUIPMENT OPERATION</b></p> <p>At every power-up phase, an automatic tuning between the transponder and the reader is performed. The aim of this automatic tuning is to reduce the environmental effects on the sensing distances (for example, material of the mounting support, room temperature). Thus, transponder and reader must be installed in their definitive operational conditions before operating the power-up.</p> <p><b>Failure to follow these instructions can result in death, serious injury, or equipment damage.</b></p>

## Functional Direction FD1 (“Face to Face” Mounting): PREFERRED CONFIGURATION

Thanks to its rotative (two positions) sensing head, the transponder sensing area can remain “face to face” with the reader sensing area allowing to keep optimized detection conditions. Even in case of different transponder mounting axes, the transponder and reader sensing areas can stay on the same axis:

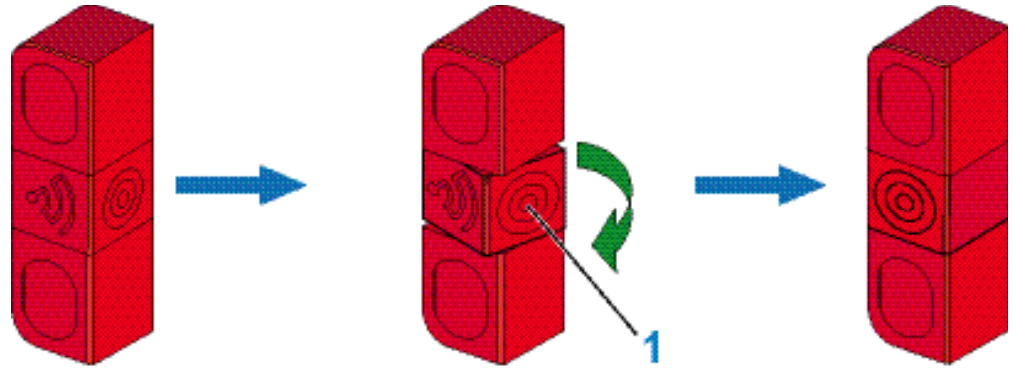

1 Transponder sensing area

In these configurations, transponder and reader sensing areas are “face to face”:

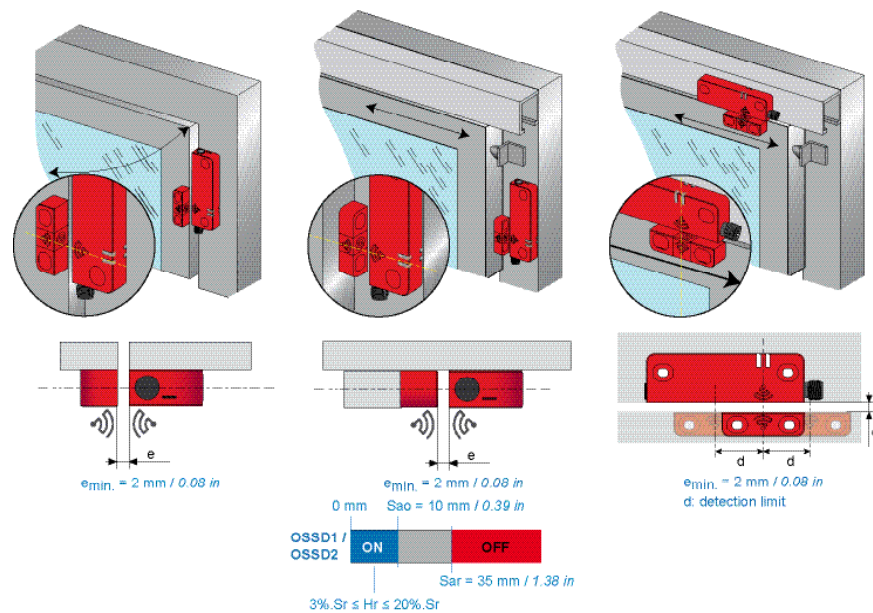

e Recommended minimum mounting distance between transponder and reader.

$S_{ao}$ ,  $S_{ar}$ , Hr values above are given without misalignment between the transponder and the reader ( $x=y=z=0$ )

NOTICE
UNINTENDED EQUIPMENT OPERATION
Do not use the XCSR reader as a mechanical stop for the mobile part of the safeguard.
Failure to follow these instructions can result in equipment damage.

Wrong mounting example:

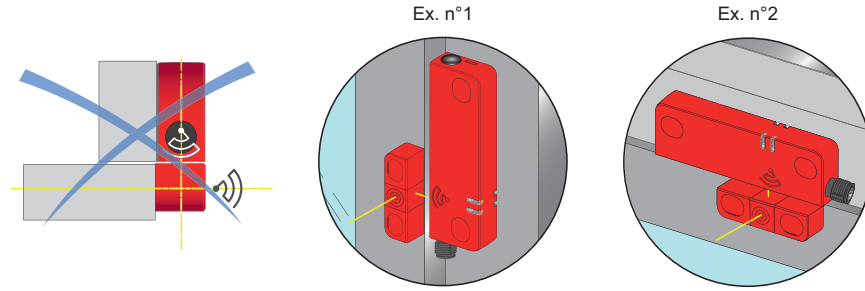

## Detection Curves for “Face to Face” Mounting: PREFERRED CONFIGURATION

Figure of  $S_{ao}$  and  $S_{ar}$  sensing distances along Y axis as function of Z

(longitudinal misalignment for X=0)

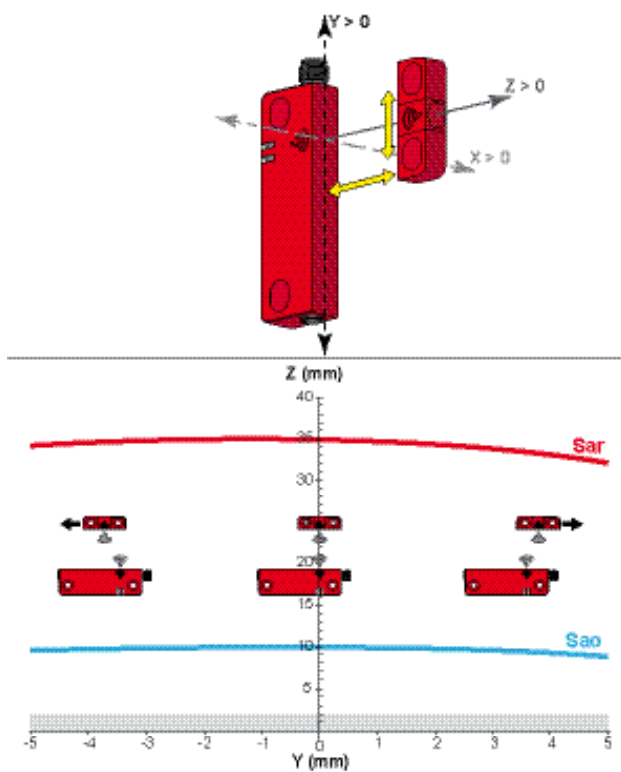
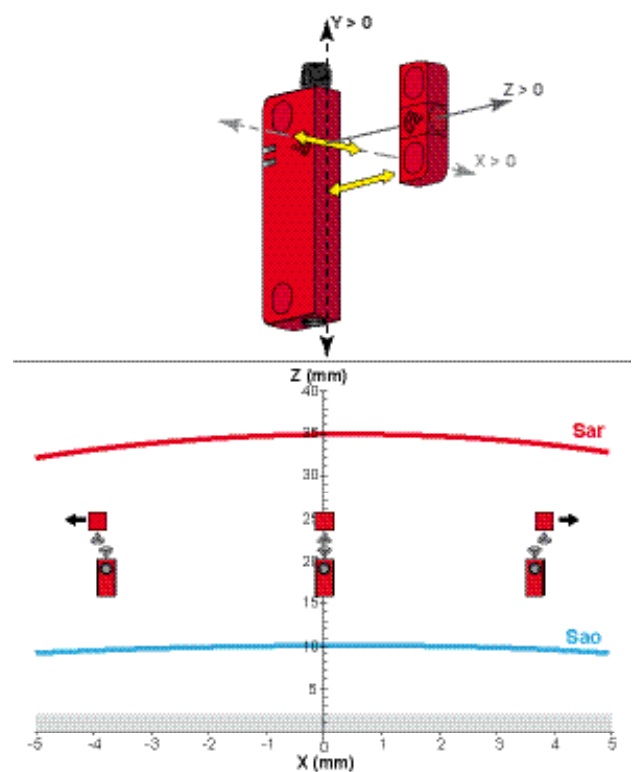

Figure of  $S_{ao}$  and  $S_{ar}$  sensing distances along X axis as function of Z

(transverse misalignment for Y=0)



Typical switch-on and switch-off sensing distances along Y axis as function of Z.

(longitudinal misalignment for X=0)

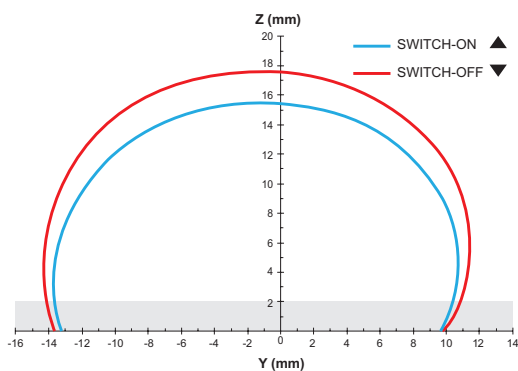

Typical switch-on and switch-off sensing distances along X axis as function of Z.

(transverse misalignment for Y=0)

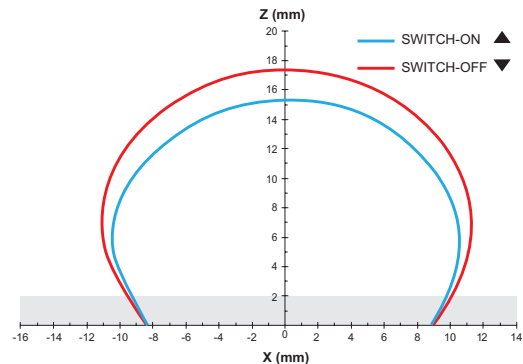

These detection curves are given in air (without metallic environment) and at ambient temperature.

## Functional Direction FD2 (“Side by Side” Mounting)

In this configuration, transponder and reader sensing areas are “side by side”:

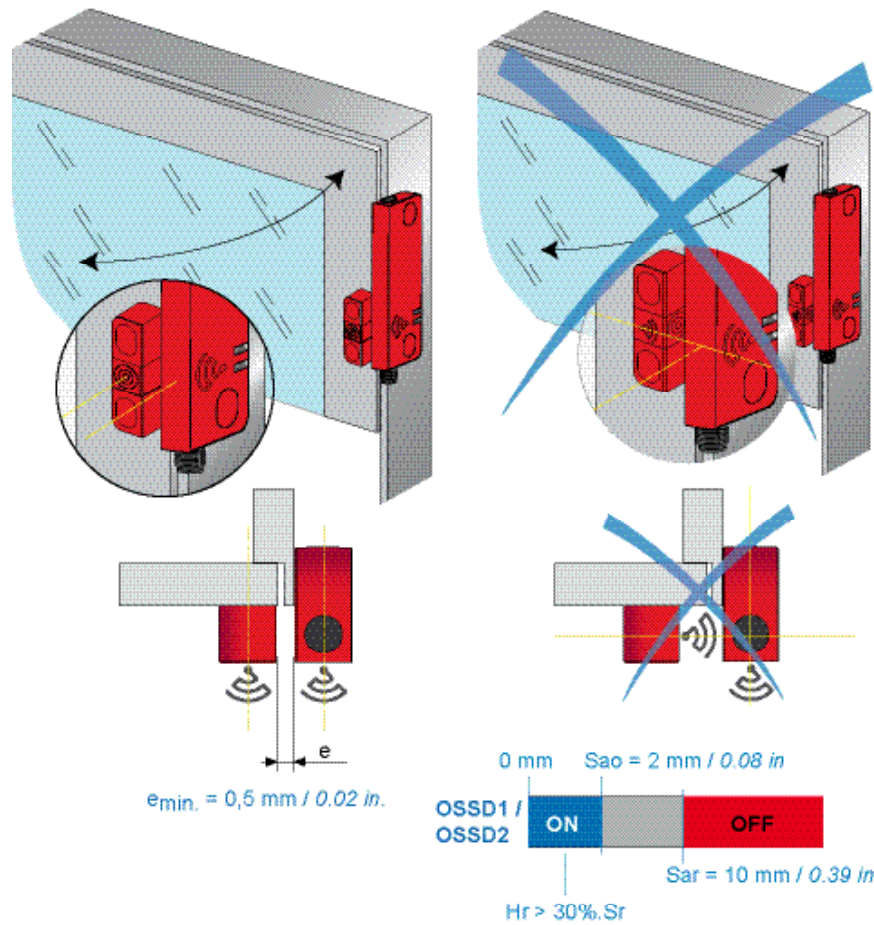

$e$  Recommended minimum mounting distance between transponder and reader.

$S_{ao}$ ,  $S_{ar}$ ,  $H_r$  values above are given without misalignment between the transponder and the reader ( $x=y=z=0$ )

### NOTICE

#### UNINTENDED EQUIPMENT OPERATION

Do not use the XCSR reader as a mechanical stop for the mobile part of the safeguard.

**Failure to follow these instructions can result in equipment damage.**

## Detection Curves for “Side by Side” Mounting

Figure of  $S_{ao}$  and  $S_{ar}$  sensing distances along Y axis as function of X

(longitudinal misalignment for Z=0)

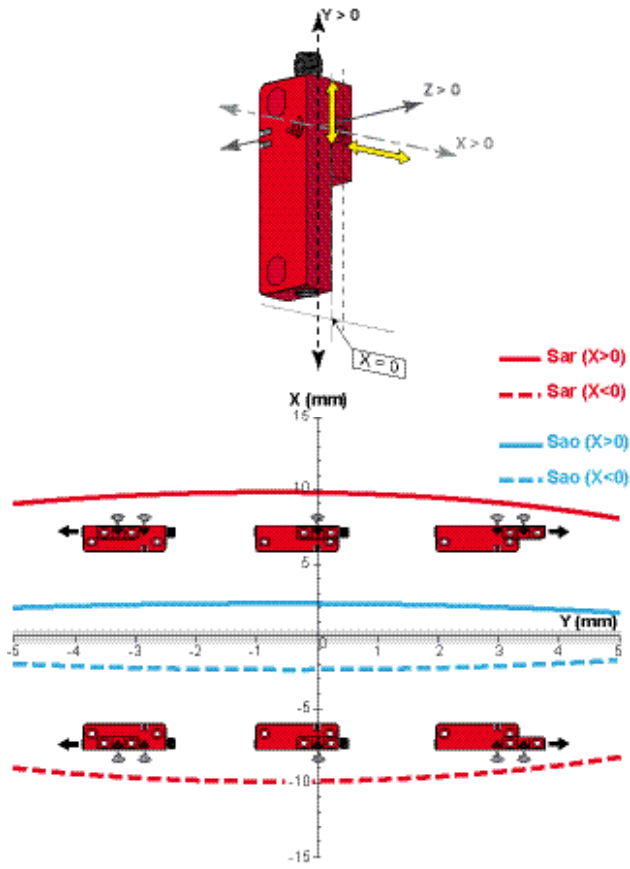
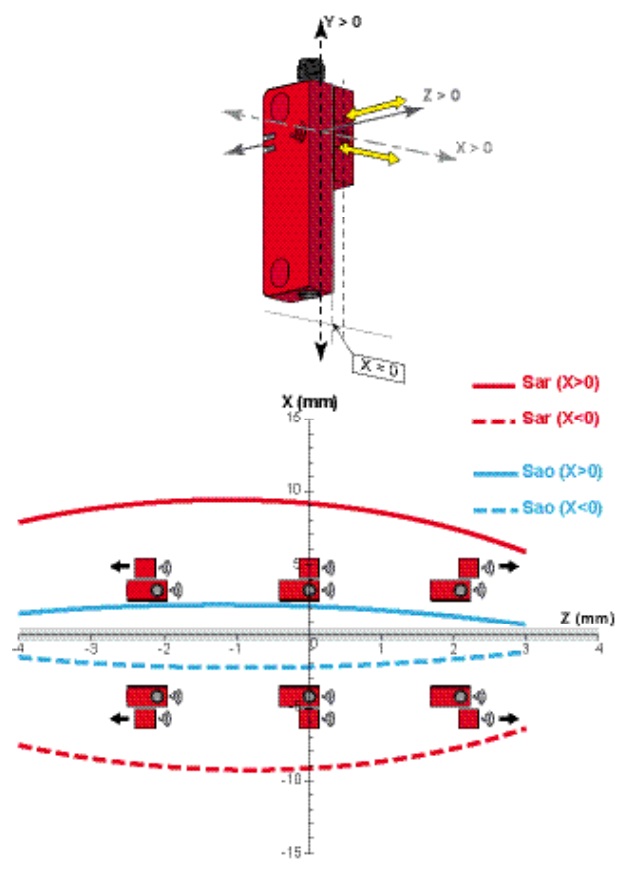

Figure of  $S_{ao}$  and  $S_{ar}$  sensing distances along Z axis as function of X

(transverse misalignment for Y=0)



# Wiring

## What's in This Chapter

Electrical Connections ..... 41  
 Connection Schematics ..... 46

## Overview

<b>⚠ WARNING</b>
<p><b>IMPROPER CONNECTION</b></p> <ul style="list-style-type: none"> <li>• The XCSR RFID Safety Switches must be powered by a dedicated safety extra low voltage (SELV) or a protected extra low voltage (PELV).</li> <li>• The external power supply must comply with IEC 60204-1.</li> </ul> <p><b>Failure to follow these instructions can result in death, serious injury, or equipment damage.</b></p>

The XCSR RFID Safety Switches operate directly from a 24 Vdc power supply. The SELV power supply part number ABL8RPS24••• is recommended. For more information, refer to [Power Supply, page 61](#).

<b>⚠ WARNING</b>
<p><b>IMPROPER CONNECTION</b></p> <ul style="list-style-type: none"> <li>• The XCSR RFID Safety Switches must be connected using both safety outputs.</li> <li>• The OSSD1 and OSSD2 output signals must not be connected between each other.</li> <li>• A single safety output, if it fails, may not stop the machine.</li> <li>• The reader provides a voltage of 24 Vdc on BOTH safety outputs. Therefore, the two loads must be individually connected between the corresponding safety output terminal and the 0 Vdc: OSSD1 --&gt;LOAD1--&gt;0 Vdc and OSSD2 --&gt;LOAD2 --&gt; 0 Vdc.</li> <li>• When connecting high inductive loads to OSSDs, use suitable voltage suppressors on the outputs.</li> <li>• The 0 Vdc must be common to all system components.</li> </ul> <p><b>Failure to follow these instructions can result in death, serious injury, or equipment damage.</b></p>

## Electrical Connections

### Single Connections (XCSRC•0M12)

This table describes the pin-wire connections for the M12, 5-pin connector of single models:

M12, 5-pin (XCSRC•0M12)		
Pin number	Description	Connector
1	+24 Vdc	
2	OSSD2	
3	0 Vdc	
4	OSSD1	
5	Not connected	

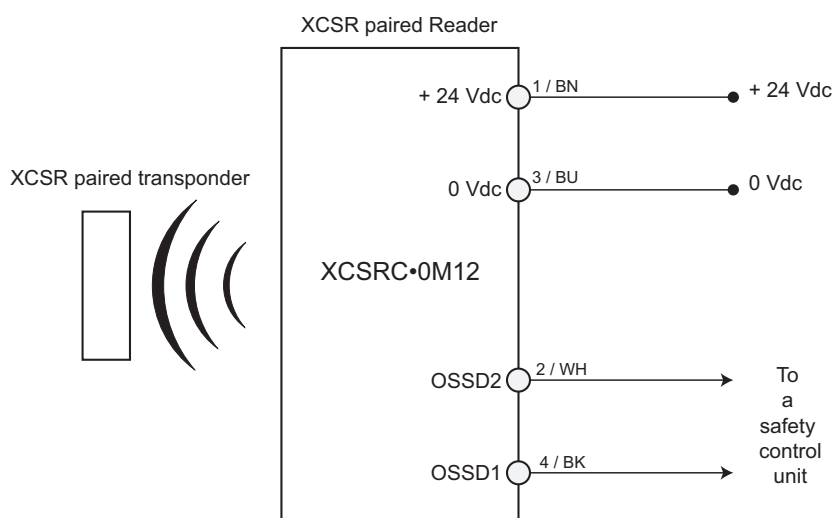

Refer to [Cable References XZCP11V12L••](#) or [XZCP12V12L••](#), page 62.

### Series Connections (XCSRC•2M12)

This figure describes the connections of daisy-chain models:

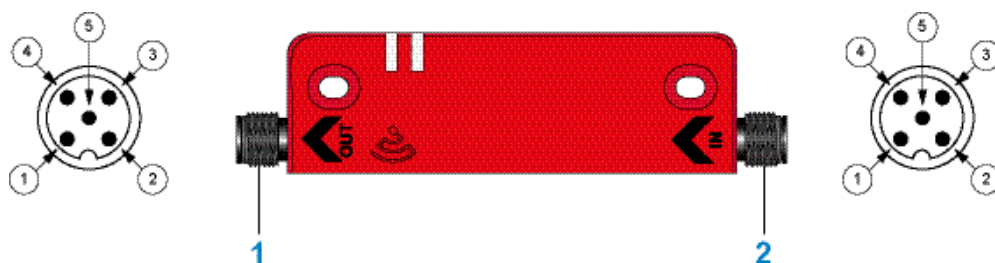

1 OUTPUT connector

2 INPUT connector

This table describes the pin-wire connections for the M12, 5-pin connectors of daisy-chain models:

M12, 5-pin (XCSRC•2M12)			
Pin number	Description		Connector
	OUTPUT connector	INPUT connector	
1	+24 Vdc	+24 Vdc	
2	OSSD2 (O2)	INPUT2 (I2)	
3	0 Vdc	0 Vdc	
4	OSSD1 (O1)	INPUT1 (I1)	
5	Diagnosis Out (Do)	Diagnosis In (Di)	

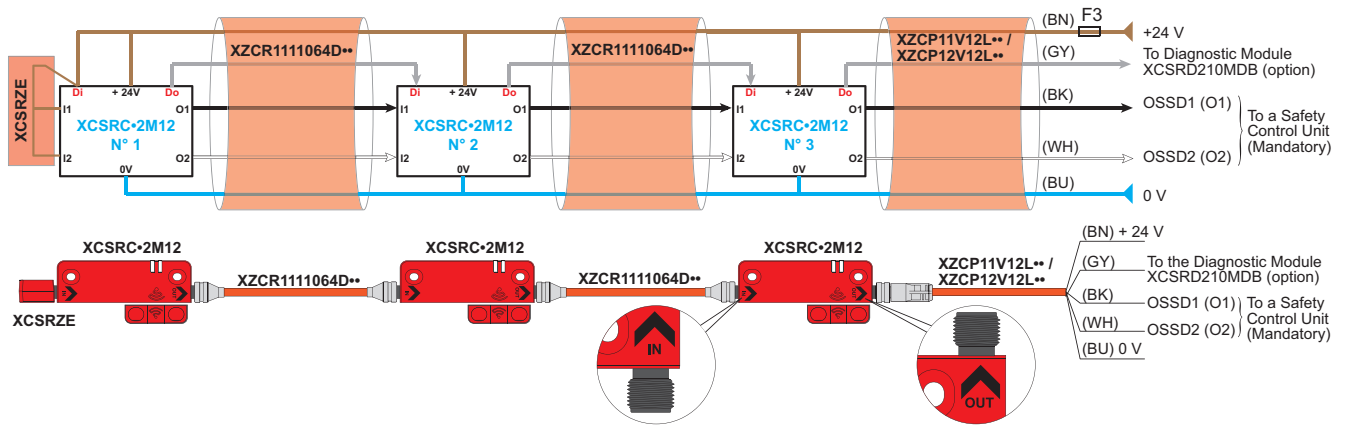

- BN** Brown
- WH** White
- BU** Blue
- BK** Black
- GY** Grey

Refer to [Cable References XZCP11V12L\\*\\*, XZCP12V12L\\*\\*, or XZCR1111064D\\*\\*, page 62.](#)

**Limitations:**

Considering only the electrical aspect, the maximum number of readers that can be connected in series depends on different factors: the cable length between each XCSR reader, the output current, the input voltage, and the wire cross section.

<b>⚠ WARNING</b>
<p><b>UNINTENDED EQUIPMENT OPERATION</b></p> <ul style="list-style-type: none"> <li>• The maximum number of XCSRC•2M12 that can be connected in series is limited to 20 and the maximum distance between 2 XCSRC•2M12 is 30 m (98.4 ft.).</li> <li>• In the following assumptions: Voltage supply 24 Vdc, Wire cross-section 0.34 mm<sup>2</sup> (AWG 22), and Output current 200 mA for each output of the last switch (connected to the safety control unit).</li> <li>• Up to 5 switches connected in series, the maximum length between each XCS-RC•2M12 is 30 m (98.4 ft.).</li> <li>• For higher numbers of switches, the maximum cable length allowed between each switch decreases.</li> <li>• For example, for 10 switches connected in series, the maximum length between each switch is 10 m (32.8 ft.).</li> </ul> <p><b>Failure to follow these instructions can result in death, serious injury, or equipment damage.</b></p>

This table gives the maximum number XCSR readers depending on the maximum cable length between 2 XCSR readers:

Maximum length between two readers	Maximum number of XCSR readers (N)	
	Cross section of the unitary wires	
	0.34 mm <sup>2</sup> (AWG 22)	0.25 mm <sup>2</sup> (AWG 23)
L = 3 m (9.84 ft)	N = 20	N = 19
L = 5 m (16.40 ft)	N = 17	N = 15
L = 10 m (32.81 ft)	N = 10	N = 9
L = 25 m (82.02 ft)	N = 6	N = 5
L = 30 m (98.42 ft)	N = 5	N = 4

Assumptions:

- VIN = 24 Vdc
- Consumption per output (OSSD1 or OSSD2) of the last XCSR reader = 0.2 A.
- Cable lengths (L) between XCSR readers are the same
- Cable length (L) between the XCSR reader and the safety control unit is the same as the cable length between XCSR readers
- XCSR devices are at the same operating temperature

## Standalone Connections (XCSRC•1•M12)

This table describes the pin-wire connections for the M12, 8-Pin connector of standalone models:

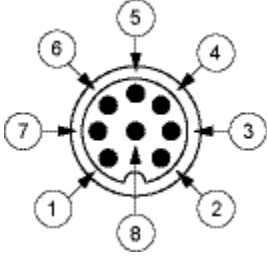
M12, 8-pin (XCSRC•1•M12)		
Pin number	Description	Connector
1	+24 Vdc	
2	OSSD2	
3	0 Vdc	
4	OSSD1	
5	EDM_ST_1	
6	EDM_ST_2	
7	Not connected	
8	Not connected	

Refer to [Cable References XZCP29P12L••](#) or [XZCP53P12L••](#), page 62.

Monitored manual start models XCSRC•1MM12:

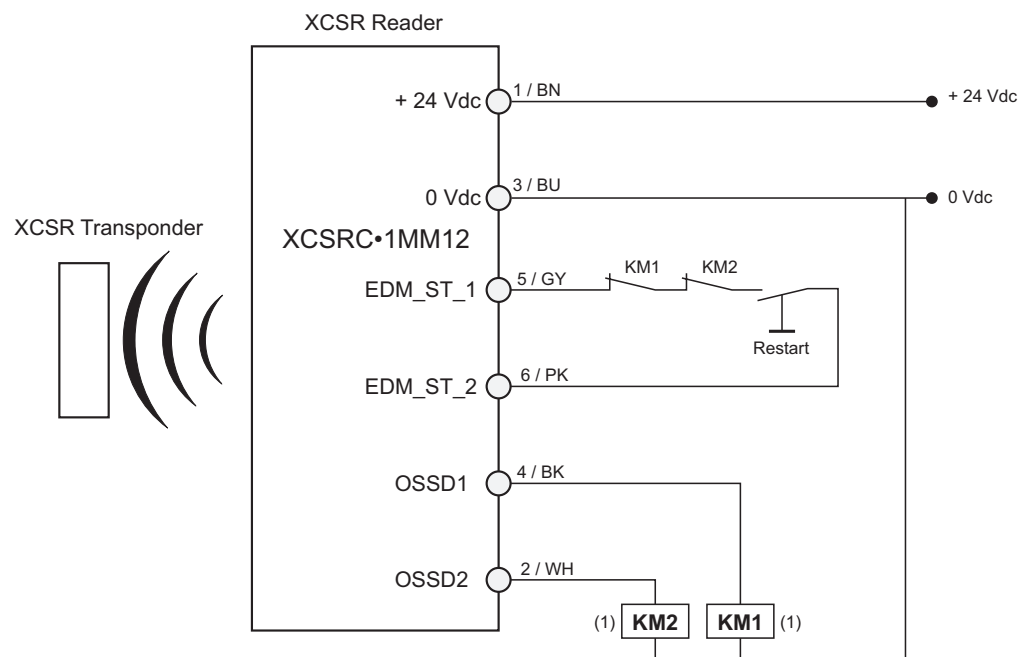

Automatic start/restart models XCSRC•1AM12:

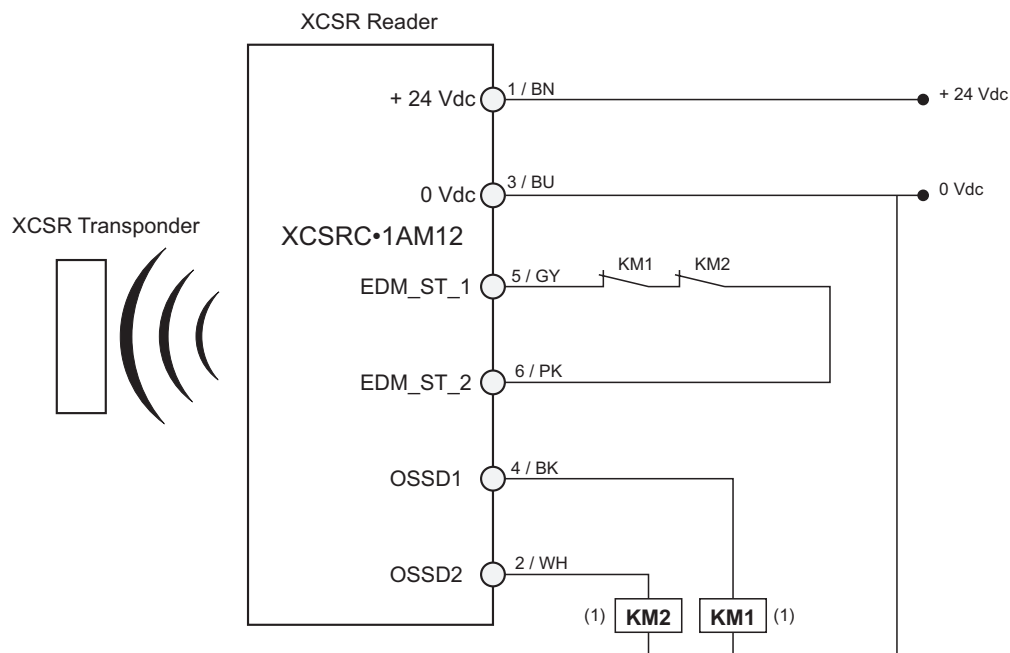

(1) Use of arc suppressors for KM1 & KM2 is recommended.

<b>⚠ WARNING</b>
<b>UNINTENDED EQUIPMENT OPERATION</b>
The KM1 and KM2 contactors must have <a href="#">force-guided contacts, page 19</a> .
<b>Failure to follow these instructions can result in death, serious injury, or equipment damage.</b>

**NOTE:** XCSR•1AM12 models can also be used with not monitored manual start/restart by adding a push button in series in the EDM loop. In this configuration, the start command is effective when the command is pressed only (0 Vdc -> 24 Vdc).

<b>⚠ WARNING</b>
<b>UNINTENDED EQUIPMENT OPERATION</b>
When configured with not monitored manual start/restart, the system cannot differentiate the press action from a short-circuit. In case of intentional (or not) short circuit of the start command, the system would be permanently reset (as for automatic start configuration). If a manual start is required, the use of monitored start command is strongly recommended (use of XCSRC•1MM12 models).
<b>Failure to follow these instructions can result in death, serious injury, or equipment damage.</b>

# Connection Schematics

## Standalone Application

The XCSRC•1•M12 standalone models can be directly connected to contactors having mechanically linked contacts (force-guided) connected to the OSSDs. In that configuration, the use of a safety relay, controller, or PLC is not compulsory.

This figure describes the wiring diagram for XCSRC•1MM12 standalone with monitored manual start and contactor contacts feedback loop (EDM):

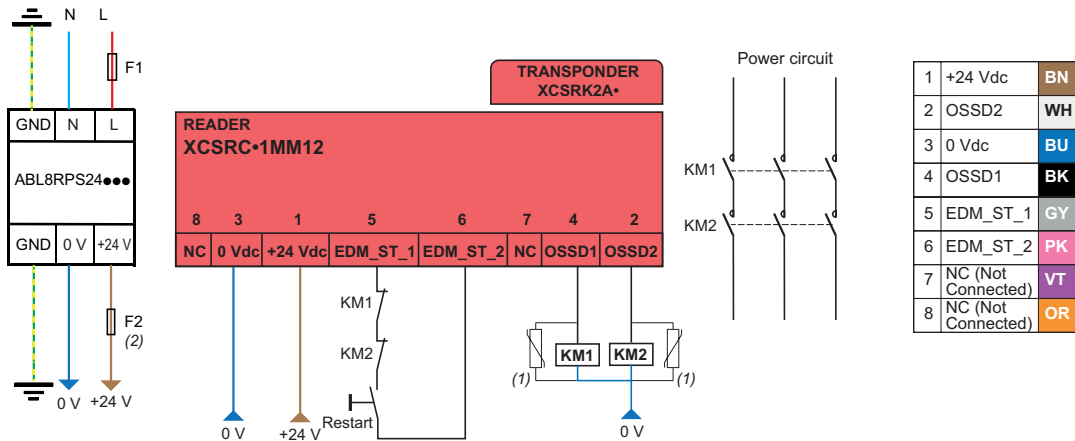

(1) Use of arc suppressors for KM1 & KM2 is recommended.

(2) 1 A maximum

- BN Brown
- WH White
- BU Blue
- BK Black
- GY Grey
- PK Pink
- VT Purple
- OR Orange
- BK/WH Black / White
- GN/YE Green / Yellow

Refer to [Cable References XZCP29P12L••](#) or [XZCP53P12L••](#), page 62.

XCSRC•1•M12 standalone models are compliant with the following standards:

- SIL3 (IEC 61508) SILCL3 (IEC 62061), and PLe- Cat.4 (ISO 13849-1)

<b>NOTICE</b>	
<b>UNINTENDED EQUIPMENT OPERATION</b>	
<ul style="list-style-type: none"> <li>• The maximum cable length for EDM/restart feedback loop and any other connections is 30 m (98.42 ft.)</li> <li>• Use of arc suppressors (1) for KM1 &amp; KM2 is recommended.</li> </ul>	
<b>Failure to follow these instructions can result in equipment damage.</b>	

<b>⚠ WARNING</b>	
<b>UNINTENDED EQUIPMENT OPERATION</b>	
The KM1 and KM2 contactors must have <a href="#">force-guided contacts</a> , page 19.	
<b>Failure to follow these instructions can result in death, serious injury, or equipment damage.</b>	

**⚠ WARNING**

**IMPROPER TYPE UTILIZATION**

It is the responsibility of the user or integrator to check whether the use of standalone XCSR RFID Safety Switch is consistent with the application risk assessment. Perform a risk assessment to choose the right product for your application.

**Failure to follow these instructions can result in death, serious injury, or equipment damage.**

## When Do We Use Safety Relays, Controllers or Safety PLCs?

The level of a complete safety system can decrease as the number of safety sensors or functions used increases. The use of safety control units like safety controllers or safety PLC can be helpful for keeping the overall system at the right safety integrity level.

Safety control unit can also be justified when additional features are required by the application. The choice between the different ranges of safety control units depends on the number of safety functions and the number of safety sensors used in the application.

This graph is a simplified representation of the common uses of safety control units:

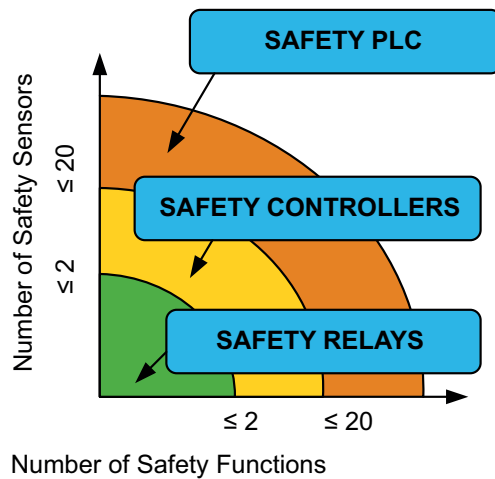

The limit numbers indicated in the graph above are not restrictive and they can vary depending on the applications.

Proof of this is the fact that in daisy-chain connection, the number of XCSR connected in series can be much larger than 2 while a simple safety relay can be used.

## Connecting to a Safety Monitoring Device

The wiring from the XCSR RFID Safety Switch to the machine control circuit must be control reliable. The solid-state outputs should be connected only to a control reliable, safety-rated PLC or to a control reliable safety-rated machine system.

## Connecting with a XPSUAK Module

This figure describes the connection of single model XCSRK2A with an XPSUAK module, with EDM and manual start with monitoring of the start button:

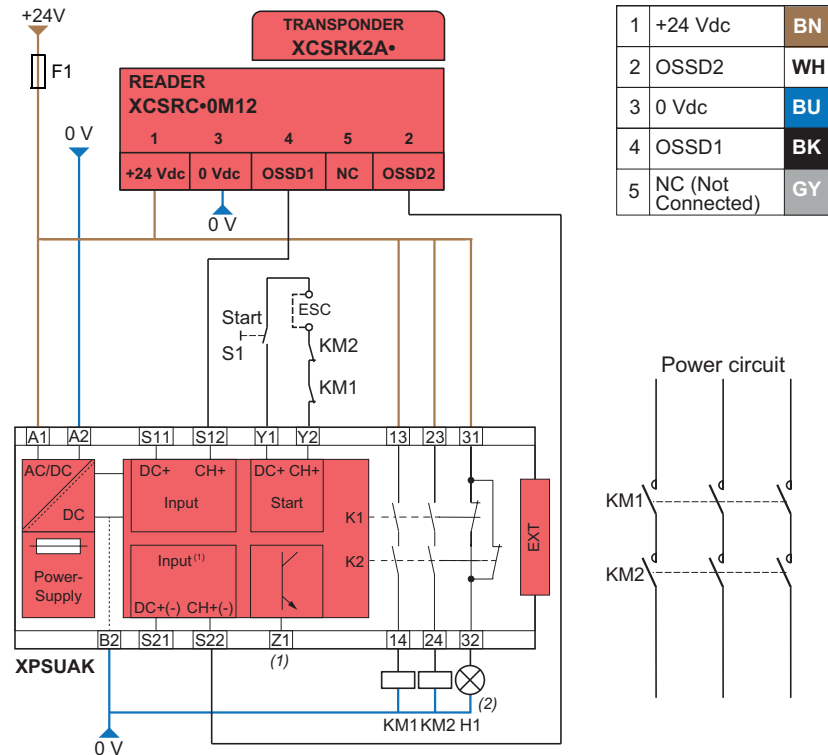

(1) Pulsed output for diagnostics

(2) XCSR RFID Safety Switch indicator light deactivated

ESC External Start Conditions

BN Brown

WH White

BU Blue

BK Black

GY Grey

Refer to [Cable References XZCP11V12L••](#) or [XZCP12V12L••](#), page 62.

Automatic start is possible by removing the start button in the schematic above (short circuit instead) and by connecting directly S13 to S14 (electrical jumper between S13 and S14).

### NOTICE

#### UNINTENDED EQUIPMENT OPERATION

The maximum cable length for EDM/restart feedback loop and any other connections is 30 m (98.42 ft.)

Failure to follow these instructions can result in equipment damage.

## ⚠ WARNING

**UNINTENDED EQUIPMENT OPERATION**

The KM1 and KM2 contactors must have [force-guided contacts](#), page 19.

**Failure to follow these instructions can result in death, serious injury, or equipment damage.**

### Connecting with a XPSUAF Module

This figure describes the series connection of five XCSRC•2M12 daisy-chain models with an XPSUAF module, with EDM and monitored manual start:

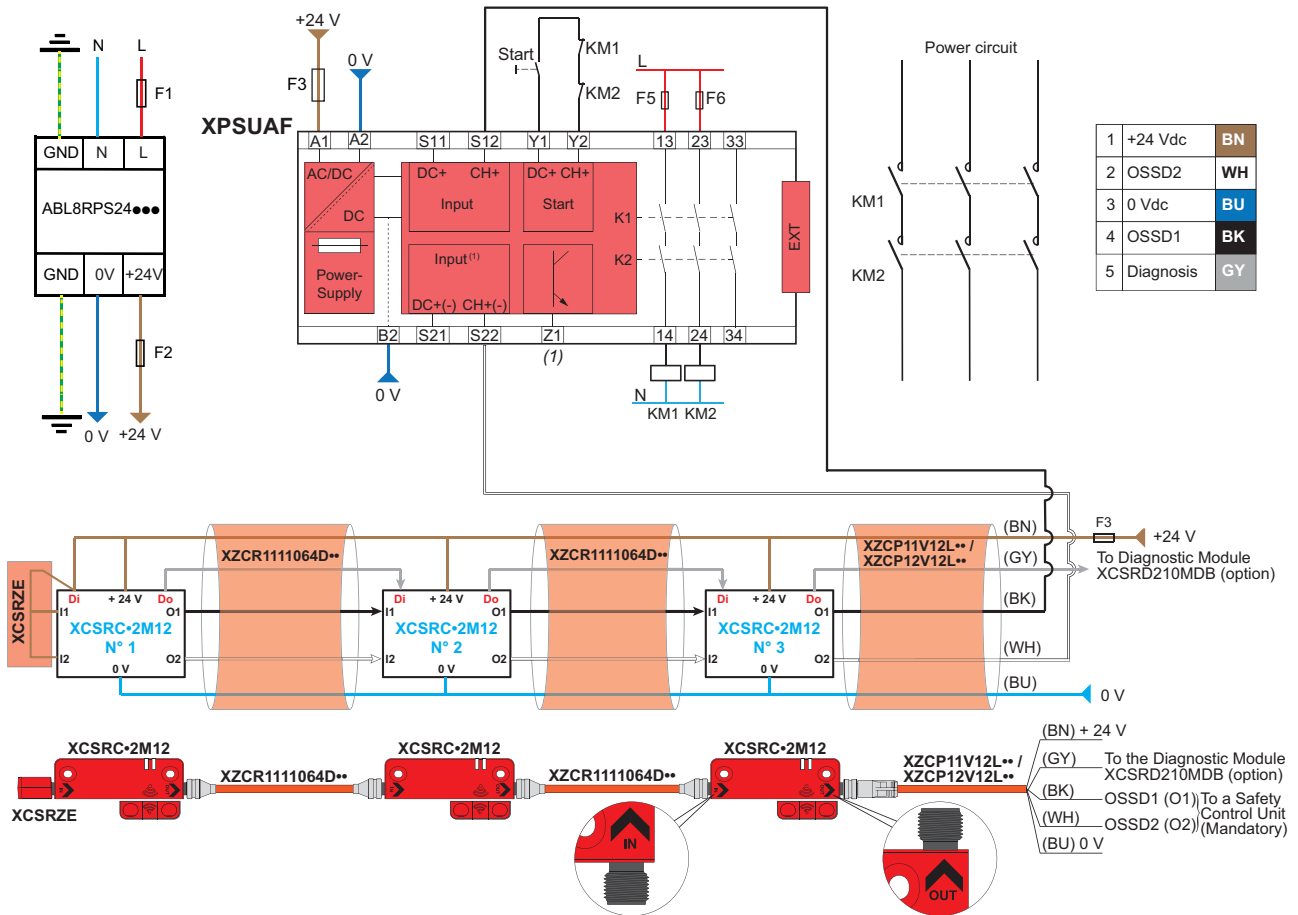

(1) Pulsed output for diagnostics

- BN** Brown
- WH** White
- BU** Blue
- BK** Black
- GY** Grey

Refer to [Cable References XZCP11V12L••](#) or [XZCP12V12L••](#), page 62.

**NOTICE**

**UNINTENDED EQUIPMENT OPERATION**

The maximum cable length for EDM/restart feedback loop and any other connections is 30 m (98.42 ft.)

**Failure to follow these instructions can result in equipment damage.**

**⚠ WARNING**

**UNINTENDED EQUIPMENT OPERATION**

The KM1 and KM2 contactors must have [force-guided contacts](#), page 19.

**Failure to follow these instructions can result in death, serious injury, or equipment damage.**

### Connecting with a XPSMCM Controller

This figure describes the connection of a XCSRC•0M12 single model with an XPSMCM controller:

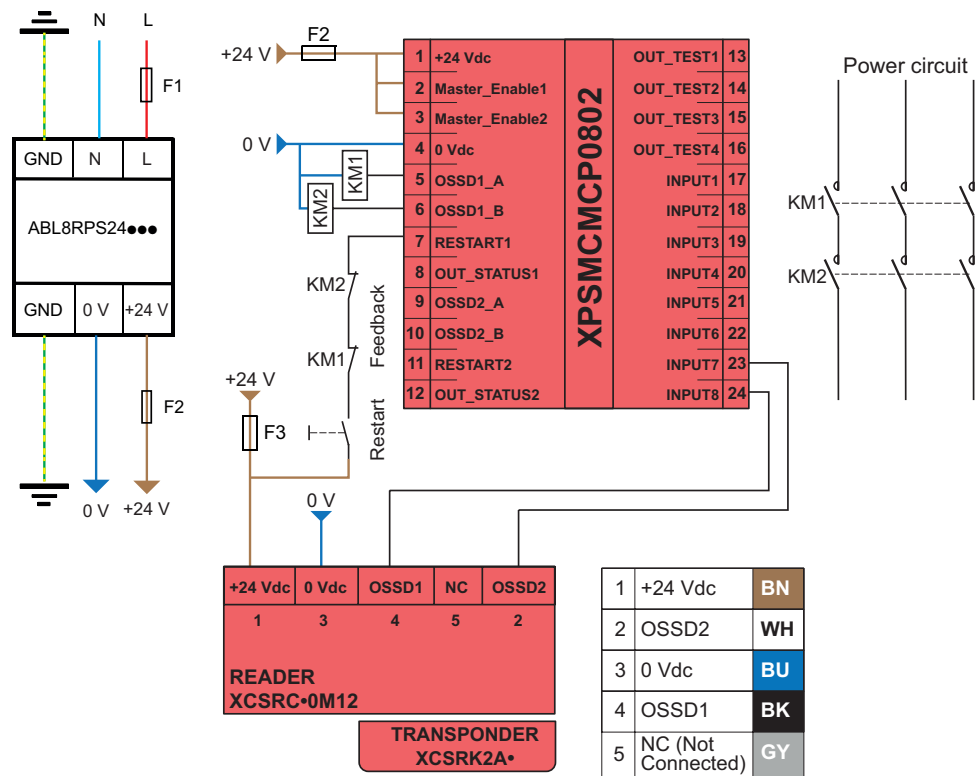

- BN** Brown
- WH** White
- BU** Blue
- BK** Black
- GY** Grey

Refer to [Cable References XZCP11V12L••](#) or [XZCP12V12L••](#), page 62.

**NOTICE****UNINTENDED EQUIPMENT OPERATION**

The maximum cable length for EDM/restart feedback loop and any other connections is 30 m (98.42 ft.)

**Failure to follow these instructions can result in equipment damage.**

** WARNING****UNINTENDED EQUIPMENT OPERATION**

The KM1 and KM2 contactors must have [force-guided contacts, page 19](#).

**Failure to follow these instructions can result in death, serious injury, or equipment damage.**

# Technical Characteristics

## What's in This Part

Technical Characteristics .....	52
---------------------------------	----

## Overview

This section provides information about the technical characteristics.

# Technical Characteristics

## What's in This Chapter

XCSR RFID Safety Switch Specifications .....	52
Safety Related Data.....	57
Dimensions .....	58
Accessories .....	61

## Overview

This chapter describes the technical characteristics of the XCSR RFID Safety Switch.

# XCSR RFID Safety Switch Specifications

## Conformity/Approvals

This table provides the standards and approvals:

<b>Conforming to standards</b>	ISO 14119, IEC 60947-5-2, IEC 60947-5-3, ETSI EN 301 489-1, ETSI EN 300 330 IEC 61508 (SIL 3), IEC 62061 (SILCL 3), ISO 13849-1 (PLe–Cat.4) UL 60947-5-2, CSA C22.2 No. 60947-5-2, CFR 47 FCC Part 15C, RSS GEN, RSS 210
<b>Approvals</b>	CE, cULus, TÜV, FCC, IC/ISED, E2

## Environmental Specifications

This table provides the environmental specifications:

Environmental characteristics	Description	
Ambient air temperature	-25...+70 °C (-13...+158 °F) Humidity < 95% - without condensation	
	-40...+85 °C (-40...+185 °F) Humidity < 95% - without condensation	
Degree of protection	IP65, IP66, and IP67 conforming with IEC 60529 IP69K conforming with DIN 40050 Enclosure type 4, 4X according to UL 50E	
Resistance to shocks and vibrations	In accordance with IEC 60947-5-3: <ul style="list-style-type: none"> <li>Shocks, conforming with IEC 60068-2-27: 30 gn (impulse duration 11 ms)</li> <li>Vibration, conforming with IEC 60068-2-6: 10 gn (10...150 Hz)</li> </ul>	
Materials	Housing: PBT + GF30% Red color: RAL 3000	
<b>Environmental chemicals</b>		
Chemical resistance	Aliphatic hydrocarbons	Resistant
	Alcohols	
	Detergents and cleansers	
	Detergents and cleansers containing alkali products	
	Alkaline (non-chlorinated) cleaning agents	
	Acid cleaning agents	
Environmental resistance	Humidity	
	Weathering (sun, water)	

## Characteristic Times

This table provides the characteristic times

Characteristic times	Unit	Value	Description
Response time	ms	Typical $T_t = 120$ ms (+ 50 ms per additional switch in Daisy-Chain configuration) $T_t = 250$ ms for standalone models	Refer to <a href="#">Definition of Characteristic Times, page 13</a>
Risk time	ms	$T_r < 120$ ms(+ 18 ms per additional switch in Daisy-Chain configuration)	
First-up time	s	$T_{ON} < 5$ s	
Pairing mode time	s	$T_{PM} = 10$ s	
Safety inputs inconsistency time	ms	$T_{IT} < 18$ ms	
OSSDs delay time	ms	$T_{DT} < 18$ ms	
OSSDs pulse width	ms	$T_{PT} = 1.4$ ms maximum under 24 Vdc with maximum load capacitance 40 nF	
OSSDs pulse Duty Cycle	ms	300 ms maximum	
Switching frequency	Hz	0.5 Hz maximum	

## Typical Operating Distances (Face to Face Mounting)

This table provides the typical operating distances:

Characteristic times	Unit	Value	Description
Typical operating sensing distance	mm	15 mm (*) (0.59 in)	FD1 Functional Direction along longitudinal axis, page 35
Assured operating sensing distance ( $S_{ao}$ )	mm	$S_{ao} = 10$ mm (0.39 in)	
Typical release sensing distance	mm	18 mm (*) (0.71 in)	
Assured release sensing distance ( $S_{ar}$ )	mm	$S_{ar} = 35$ mm (1.38 in)	
Repeat accuracy	–	$\leq 10\% \times S_r$	
Typical hysteresis	–	$3\% \times S_r \leq H \leq 20\% \times S_r$	

(\*) Ambient temperature, on non-magnetic support, without misalignment between the transponder and the reader.

## Electrical Characteristics

The given table provides the electrical characteristics:

Electrical characteristics	Unit	Description
Power supply	V	24 Vdc -20% +10% The power supply must meet requirements of IEC 60204-1 relative to SELV/PELV power supply.
Maximum current consumption (no load)	mA	60 mA
Rated impulse withstand voltage	kV	$U_{imp} = 0.8$ kV
EMC immunity withstands	–	Conforming IEC 60947-5-2, IEC 60947-3, EN IEC 61326-3-1, and ETSI EN 301 489-1
Safety outputs (OSSD)	–	<p>Two OSSDs PNP:</p> <ul style="list-style-type: none"> <li> <b>Standalone XCSRC•1•M12:</b>            Maximum 400 mA per output at 24 Vdc            Drop out voltage &lt; 2 Vdc            Leakage current (OFF state) &lt; 1 mA            Maximum load inductance 3 H, 110 <math>\Omega</math> under 24 Vdc            Maximum load capacitance 40 nF under 24 Vdc            Switching capacity: DC12 &amp; DC13: <math>U_e = 24</math> Vdc - <math>I_e = 400</math> mA         </li> <li> <b>Single and daisy-chain XCSRC•0M12 and XCSRC•2M12:</b>            Maximum 200 mA per output at 24 Vdc            Drop out voltage &lt; 2 Vdc            Leakage current (OFF state) &lt; 1 mA.            Maximum load capacitance 40 nF under 24 Vdc            Switching capacity: DC12: <math>U_e = 24</math> Vdc - <math>I_e = 200</math> mA         </li> </ul> <p>DC12: Resistive load (all versions)            DC13: Inductive load (standalone versions)            Short Circuit protection conforming to IEC 60947-5-2</p>
Safety-related inputs	–	<p>Two DC digital positive inputs</p> <p>Maximum load capacitance 10 nF under 24 Vdc</p> <p>24 Vdc -20% +10%</p> <p>Current consumption &lt; 5 mA</p>
Maximum XCSR RFID switches connectable in series	–	< 20 XCSRC•2M12 (refer to <a href="#">Series Connections, page 41</a> )
Signals	–	2 three-color LEDs - Red/Green/Orange
Connections	–	<p>Single XCSRC•0M12: 5 pins male M12 connector</p> <p>Standalone XCSRC•1•M12: 8 pins male M12 connector</p> <p>Daisy-chain XCSRC•2M12: 2 x 5 pins male M12 connector</p> <p>Refer to <a href="#">Electrical Connections, page 41</a>.</p>
Protection against electric shocks	–	Class III as per IEC 61140

## Radio-Emission Characteristics

The given table provides the radio-emission characteristics:

Radio-emission characteristics	Unit	Description
Carrier frequency	MHz	13.56 MHz
Operating frequency band	MHz	13.553...13.567 MHz (Sub band j.2 from appendix 9 of ERC/REC 70-03)
Maximum radiated magnetic field	dBµA/m	-7.77 dBµA/m at 10 m, according to ETSI EN 300 330

### WARNING TO USERS IN THE UNITED STATES

This device must be professionally installed.

This equipment complies with FCC’s radiation exposure limits set forth for an uncontrolled environment under the following conditions :

1. This equipment should be installed and operated such that a minimum separation distance of 20cm is maintained between the radiator (antenna) and user’s/nearby person’s body at all times.
2. This transmitter must not be co-located or operating in conjunction with any other antenna or transmitter.

This equipment has been tested and found to comply with the limits for a Class B digital device, pursuant to Part 15 of the FCC Rules. These limits are designed to provide reasonable protection against harmful interference in a residential installation. This equipment generates uses, and can radiate radio frequency energy and, if not installed and used in accordance with the instructions, may cause harmful interference to radio communications. However, there is no guarantee that interference will not occur in a particular installation.

- Reorient or relocate the receiving antenna.
- Increase the separation between the equipment and receiver.
- Connect the equipment into an outlet on a circuit different from that to which the receiver is connected.
- Consult the dealer or an experienced radio/TV technician for help.

### NO UNAUTHORIZED MODIFICATIONS

**CAUTION:** This equipment may not be modified, altered, or changed in any way without signed written permission from TMSS France. Changes or modifications not expressly approved by the party responsible for compliance could void the user’s authority to operate he equipment and will void the warranty.

### WARNING TO USERS IN THE CANADA / ATTENTION POUR LES UTILISATEURS AU CANADA

This device contains licence-exempt transmitter(s)/receiver(s) tant comply with Innovation, Science and Economic Development Canada’s licence-exempt RSS(s).

1. This device may not cause interference, and
2. This device must accept any interference received, including interference that may cause undesired operation of the device.

This equipment complies with RSS102’s radiation exposure limits set forth for an uncontrolled environment under the following conditions:

1. This equipment should be installed and operated such that a minimum separation distance of 20cm is maintained between the radiator (antenna) and user’s/nearby person’s body at all times.
2. This transmitter must not be co-located or operating in conjunction with any other antenna or transmitter.

*L'émetteur/récepteur exempt de licence contenu dans le présent appareil est conforme aux CNR d'Innovation, Sciences et Développement économique Canada applicables aux appareils radio exempts de licence:*

1. L'appareil ne doit pas produire de brouillage, et
2. L'appareil doit accepter tout brouillage radioélectrique subi, même si le brouillage est susceptible d'en compromettre le fonctionnement.

Cet équipement est conforme aux limites d'expositions de la CNR102 applicables pour un environnement non contrôlé aux conditions suivantes:

1. Cet équipement devra être installé et fonctionner de telle manière qu'une distance minimale de séparation de 20 cm soit maintenue entre la partie rayonnante (l'antenne) et l'utilisateur / les personnes à proximité à tout moment.
2. Cet émetteur ne doit pas être co-localisé ou opérer en conjonction avec toute autre antenne ou émetteur.

**References:**

Reference	XCSR••M12
FCC ID	2BCVYXCSR
IC	31308-XCSR
PMN	XCSRC••M12

## Safety Related Data

### General Description

This table provides safety related data for the XCSR RFID Safety Switches:

<b>Mission Time (TM) ISO 13849-1</b>	<b>PFH<sub>d</sub> ISO 13949-1 and IEC 62061</b>
20 years	5x10 <sup>-10</sup> Per reader

For safety related data definitions, refer to the Glossary.





## XCSRK2A• Dimensions

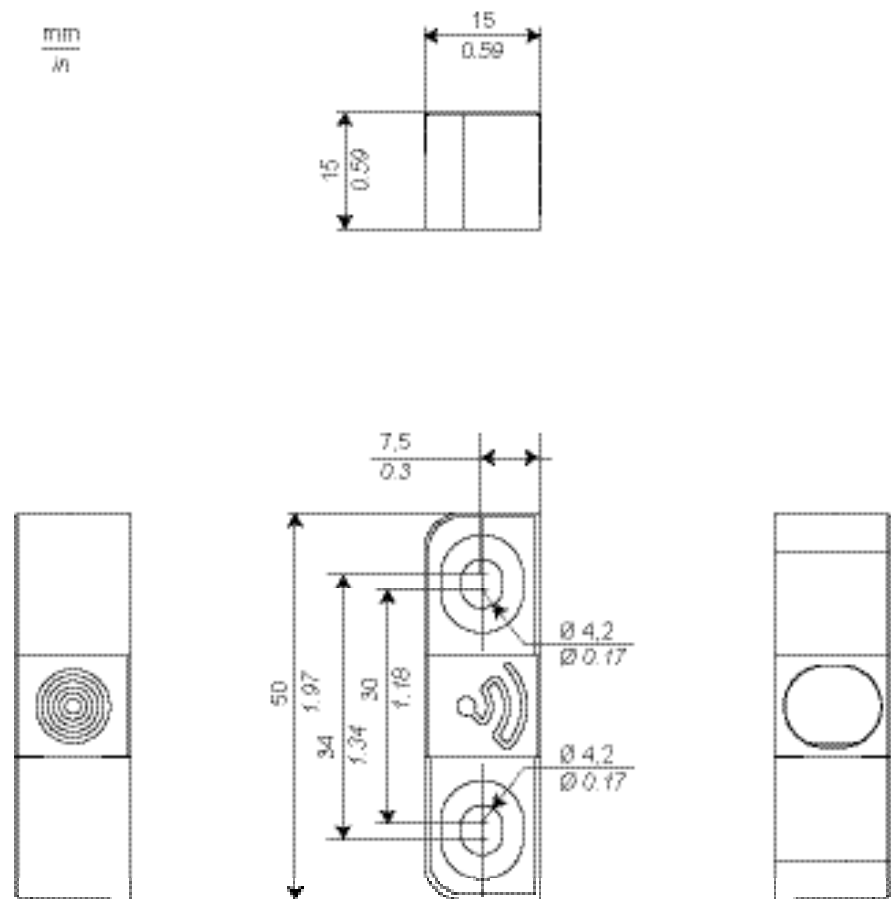

## XCSRZE Dimensions

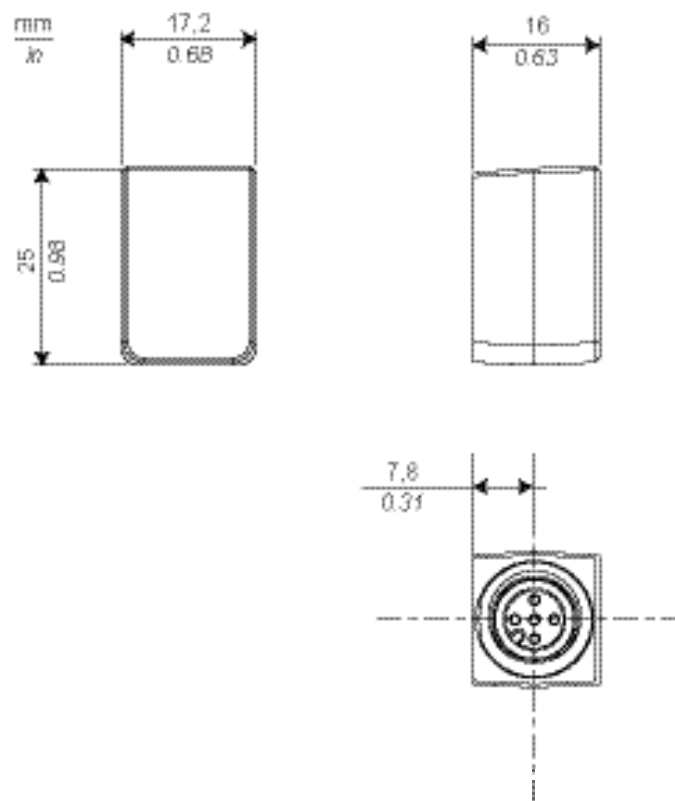

## Accessories

### Power Supply

The power supply must meet the requirements of IEC 60204-1 and IEC 61496-1. The SELV part number ABL8RPS24... is recommended.

This figure describes the power supply ABL8RPS24...:

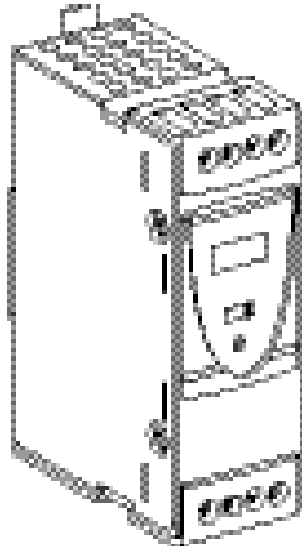

**ABL8RPS24... Operating temperature range -25...60 °C without derating:**

Input voltage	Secondary			Reset	Conforming to standard IEC 61000-3-2	Reference
	Output voltage (V)	Nominal power (W)	Nominal current (A)			
Single to phase (N-L1) 100...120 Vac -15 +10% (50 Hz or 60 Hz)	24...28.8	72	3	Auto/Manual	Yes	ABL8RPS-24030
		120	5	Auto/Manual	Yes	ABL8RPS-24050
		240	10	Auto/Manual	Yes	ABL8RPS-24100
Phase to phase (L1-L2) 200...500 Vac -15 +10% (50 Hz or 60 Hz)						

## Mounting Accessories

This table describes the XCSZ72 one-way screw that should be used to mount the XCSR RFID Safety Switches:

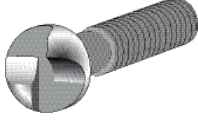
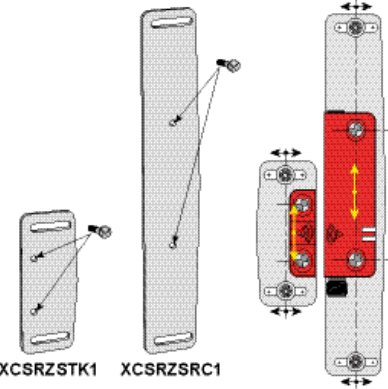
Reference	Description	
XCSZ72	One-way screw, M4x35mm	
XCSZ71	One-way screw, M4x14mm	
XCSRZSRC1(1)(2)	Mounting plate for readers XCSR•••M12	
XCSRZSTK1(1)(2)	Mounting plate for transponders XCSRK2A•.	
<p>(1) 2 one-way screws M4x12 mm for fixing the transponder and the reader on their mounting supports are respectively provided with the XCSRZSTK1 and XCSRZSRC1 accessories.</p> <p>(2) For fixing the mounting support on the machine, the use of M5 tamper-proof screws is strongly recommended.</p>		

## Cables

This table describes the 5-pin cables for use with single (XCSR•0M12) models and for the connection between a safety control unit and the last reader of a daisy-chain (XCSR•2M12):

Cables (pre-wired 5 pins)	Description	Length
XZCP11V12L2	Connector M12 - Female - Straight - 5 poles - PUR - pre-wired 0.34 mm <sup>2</sup> (AWG22). Unshielded cable	2 m (6.56 ft)
XZCP11V12L5		5 m (16.4 ft)
XZCP11V12L10		10 m (32.8 ft)
XZCP11V12L20		20 m (65.6 ft)
XZCP12V12L2	Connector M12 - Female - 90° - 5 poles - PUR - pre-wired 0.34 mm <sup>2</sup> (AWG22). Unshielded cable	2 m (6.56 ft)
XZCP12V12L5		5 m (16.4 ft)
XZCP12V12L10		10 m (32.8 ft)
XZCP12V12L20		20 m (65.6 ft)
XZCC12FDM50B	Connector M12 - Female - Straight - 5 poles with screw terminals - cable gland - Metal clamping ring	-
XZCC12FCM50B	Connector M12 - Female - 90° - 5 poles with screw terminals - cable gland - Metal clamping ring	-

M12 5-pins connector description:

Pin number	Wire color	Connector
1	Brown	
2	White	
3	Blue	
4	Black	
5	Gray	

This table describes the jumper cables for direct series connection (daisy-chain XCSRC•2M12):

Cables (jumpers 5 pins)	Description	Length
XZCR1111064D03	2 straight M12 - Female/Female - PUR - 5 poles 0.34 mm <sup>2</sup> (AWG22). Unshielded cable	0.3 m (0.98 ft)
XZCR1111064D3		3 m (9.84 ft)
XZCR1111064D5		5 m (16.4 ft)
XZCR1111064D10		10 m (32.8 ft)
XZCR1111064D25		25 m (82.02 ft)

This table describes the 8-pin cables for standalone XCSRC•1M12 models:

Cables (pre-wired 8 pins)	Description	Description
XZCP29P12L2	Connector M12 - Female - Straight - 8 poles - PUR - pre-wired 0.34 mm <sup>2</sup> (AWG22). Unshielded cable	2 m (6.56 ft)
XZCP29P12L5		5 m (16.4 ft)
XZCP29P12L10		10 m (32.8 ft)
XZCP29P12L20		20 m (65.6 ft)
XZCP53P12L2	Connector M12 - Female - 90° - 8 poles - PUR - pre-wired 0.34 mm <sup>2</sup> (AWG22). Unshielded cable	2 m (6.56 ft)
XZCP53P12L5		5 m (16.4 ft)
XZCP53P12L10		10 m (32.8 ft)
XZCP53P12L20		20 m (65.6 ft)
XZCC12FDM80B	Connector M12 - Female - Straight - 8 poles with screw terminals - cable gland - Metal clamping ring	-
XZCC12FCM80B	Connector M12 - Female - 90° - 8 poles with screw terminals - cable gland - Metal clamping ring	-

M12 8-pins connector description:

Pin number	Wire color	Connector
1	Brown	
2	White	
3	Blue	
4	Black	
5	Gray	
6	Pink	
7	Purple	
8	Orange	

# XCSR210MDB Diagnostic Module

## What's in This Part

XCSR210MDB Diagnostic Module..... 64

# XCSR210MDB Diagnostic Module

## What's in This Chapter

Overview..... 64  
 Description..... 65  
 Connections Configuration ..... 66  
 Wiring..... 68  
 Diagnostic LED ..... 70  
 Modbus Registers..... 71  
     Operating..... 76  
     Characteristics ..... 78

## Overview

### Overview

<b>⚠ WARNING</b>
<p><b>IMPROPER UTILIZATION</b></p> <ul style="list-style-type: none"> <li>• Do not use the Diagnostic module as a safety equipment. Diagnostic function is not part of safety function.</li> <li>• Do not use the Diagnostic module with 8-multiple numbers of XCSR switches in series.</li> </ul> <p><b>Failure to follow these instructions can result in death, serious injury, or equipment damage.</b></p>

The diagnostic module interprets the diagnostic data of the whole chain, and makes this information available into Modbus registers. Reception of diagnostic data frame is periodic, approximately every 2 s.

Main features of the Diagnostic function:

- The diagnostic function provides the state of all XCSR•2M12 monitored by the safety chain. It identifies which guards are opened or closed.
- The diagnostic function prevents a new start of the machine if the chain has been tampered, if any XCSR•2M12 has failed, or in case of wiring disconnection.
- The diagnostic function detects if the loopback device is not connected and prevent a new start until the loopback device is connected and a power cycling has been done.

# Description

## Product Description

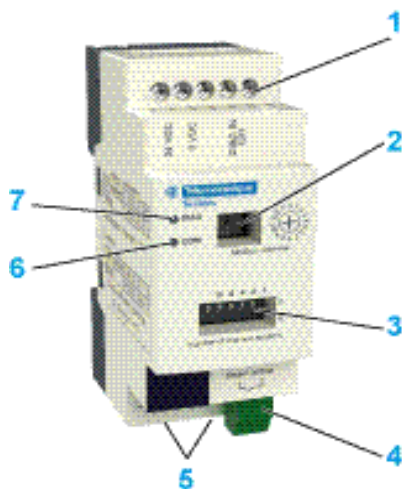

Item	Description	Refer to...
1	Five screw terminals for electrical wiring and the diagnostic signal	<a href="#">Inputs / Power Supply Wiring, page 68</a>
2	Rotary switch with 16 positions for setting the Modbus address	<a href="#">Operating Hardware Installation, page 76</a>
3	Micro-switches for setting the number of XCSRC•2M12 connected in series	
4	Plug-in connector for Chain Error potential-free contact (CE/External Start Condition)	<a href="#">CE Wiring, page 68</a>
5	Two RJ45 sockets for Modbus communication.	<a href="#">Communication Wiring, page 68</a>
6	Modbus LED	<a href="#">Diagnostic LED, page 69</a>
7	Diagnostic LED	

# Connections Configuration

## Connections Configuration

The diagnostic module can be used with “daisy chain” XCSRC•2M12 Safety Switches. It must be connected to the end of the chain.

The last XCSRC•2M12 of the chain (end of chain) is the one which is connected to the safety control unit (safety relay/controller...).

The first XCSRC•2M12 is the one connected to the loopback device (XCSRZE).

The diagnostic module can monitor up to 20 XCSRC•2M12 connected in series.

**NOTE:** The use of the diagnostic module is optional, but strongly recommended due to his ability to detect, warn and localize errors on the chain or eventual tampering and thus prevent from machine restart until the chain comes back to a correct operating state.

### **WARNING**

#### **IMPROPER UTILIZATION**

- The diagnostic module, every XCSRC•2M12, and the safety control unit must be powered by the same SELV/PELV power supply.
- The external power supply must comply with IEC 60204-1.

**Failure to follow these instructions can result in death, serious injury, or equipment damage.**

Wiring is described below:

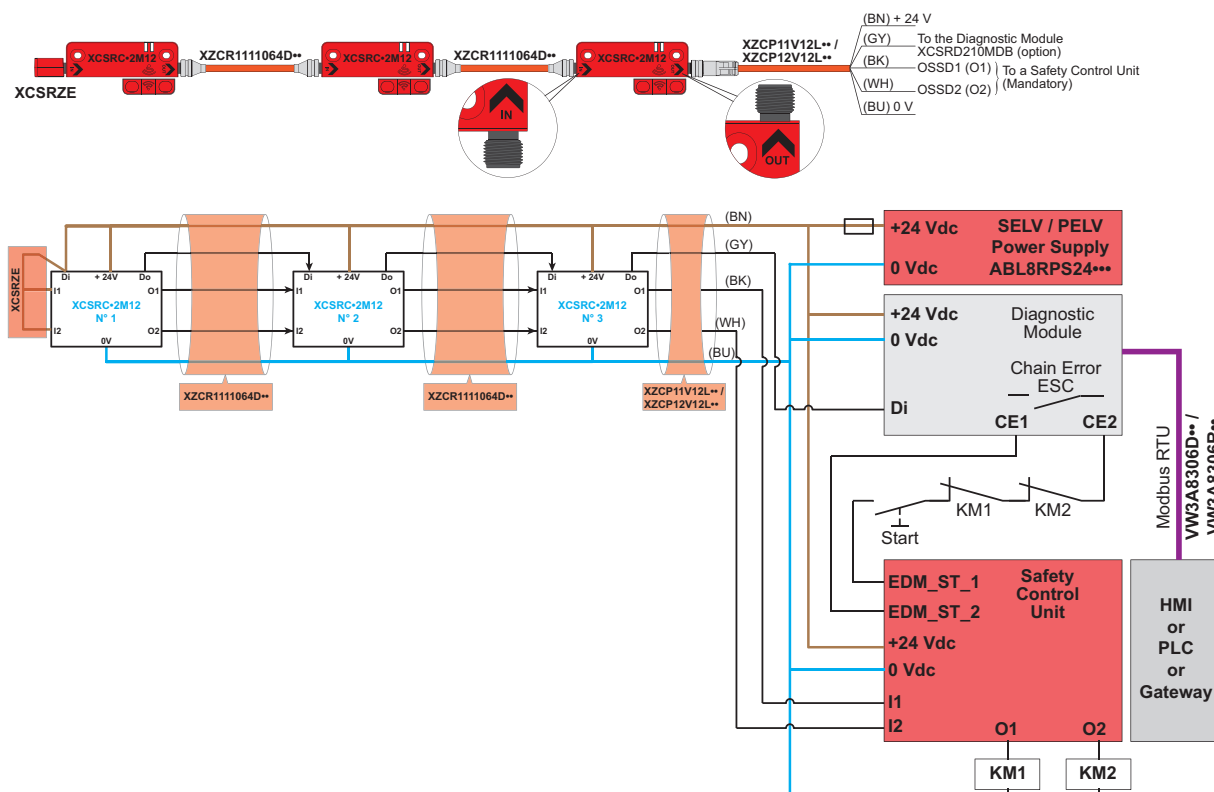

**Di** Diagnostic signal input

**Do** Diagnostic signal output

**I1** Safety Input 1

**I2** Safety Input 2

**O1** Safety Output 1

**O2** Safety Output 2

**CE1 & CE2** Connections for Chain Error contact (used as External Start Condition -ESC)

**BN** Brown

**WH** White

**BU** Blue

**BK** Black

**GY** Grey

## Wiring

### Inputs / Power Supply Wiring

Five screw terminals (top):

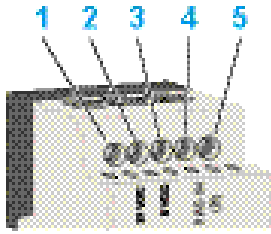
Pin out	Description	View
1	+24 Vdc	
2	0 Vdc	
3	Not connected	
4	Diagnostic input (Di)	
5	Not connected	

### Communication Wiring

2 RJ45 8 wires:

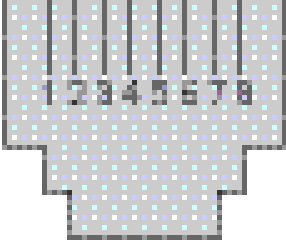
Pin out	Description	View
1	Not connected	
2	Not connected	
3	Not connected	
4	D1	
5	D2	
6	Not connected	
7	+5 Vdc	
8	Common (0 Vdc)	

### CE Wiring

One terminal block:

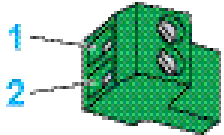
Pin out	Description	View
1	CE1	
2	CE2	

For more details, refer to [Chain Error status description](#), page 68.

### Chain Error (CE / External Start Condition)

The diagnostic module provides a potential free contact.

The Chain Error contact (CE) does not provide information to stop the machine and is not part of the safety function.

The Chain Error contact (CE) opens in the following cases:

- During the initialization state,
- In [error state](#), page 70.

Otherwise the Chain Error contact is closed.

Once opened, CE cannot be closed until next power-up and restart cycle (if the configuration and the number of switches are consistent and if the XCSR•2M12 are not in fail conditions).

For example, the Chain Error contact can be used to detect a difference between the number of XCSR•2M12 physically connected in series and the number configured on the micro-switches (For example: sensor by-pass).

# Diagnostic LED

## Overview

The diagnostic module has two three-color LEDs

- One LED for the diagnostic function.
- One LED for the Modbus function.

## Diagnostic LEDs

Diagnostic LED Description:

Color	Description
Orange	Initialization state.
Green	Run state: Correct diagnostic data frame received.
Red	Error state: <ul style="list-style-type: none"> <li>• Inconsistency between the number of XCSRC•2M12 physically connected in series and the value set on the micro-switches,</li> <li>• The number of XCSRC•2M12 chained is greater than 20,</li> <li>• XCSRZE loopback device not connected,</li> <li>• At least one XCSRC•2M12 is in failure mode,</li> <li>• Detection of cable disconnection.</li> </ul>
OFF	No diagnostic data received or no detected error or power off.

## Modbus LEDs

Modbus LED Description:

Color	Description
Orange	Initialization state: Modbus auto baudrate detection function.
Green	Run state: Correct Modbus data frame received.
Blinking	
Red	Error state: Incorrect Modbus data frame received.
Blinking	
OFF	No Modbus data received or no detected error or power off.

# Modbus Registers

## Modbus Protocol

Main features:

Communication of the diagnostic data to a controller or an external display,

 <b>WARNING</b>
<p><b>IMPROPER CONNECTION</b></p> <p>Controller or external display must be powered by the RJ45 (pin 7 and 8, Modbus CP5S).</p> <p><b>Failure to follow these instructions can result in death, serious injury, or equipment damage.</b></p>

The only supported Modbus request is Read holding registers (code 03h).

The Modbus protocol is Remote Terminal Unit (RTU).

**NOTE:** Connection to a Modbus TCP/IP device is possible with the use of TSXETG100 gateway. Refer to the [Modbus TCP/IP Wiring Example, page 72](#).

The detection of the Modbus line configuration is automatic. The automatic detection is activated after a power-up during the initialization phase. The duration of the initialization phase is 5 s.

Modbus settings accepted:

Type	Values
Baud rate (bit/s)	9600, 19200 (by default), 38400, 57600, 76800, 115200
Parity	None (by default), Even, Odd

## Modbus TCP/IP Wiring Example

Connection of a XCSR210MDB to a Modbus TCP/IP device with a TSXETG100 gateway:

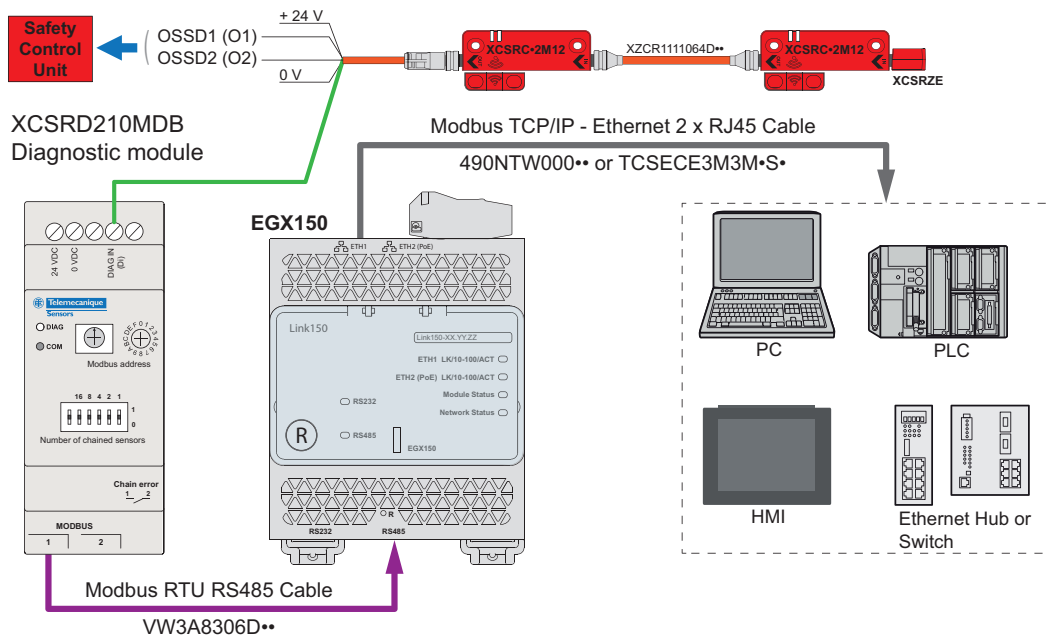

## Modbus Registers

Modbus Registers:

Address	Register	Word	Description	Bit used
0x0000	1	Word 0	Error description	0...4
0x0001	2	Word 1	State of the first sixteen XCSRC•2M12	0...15
0x0002	3	Word 2	State of the last four XCSRC•2M12	0...3
0x0003	4	Word 3	Position of cable disconnection or XCSRC•2M12 in failure mode.	0...4
0x0004	5	Word 4	Number of XCSRC•2M12 in the chain set on the micro-switches.	0...4

## User Registers

Register 1 = Word 0:

Bit	Default value	Value	Description
15 (MSB)	0	Not used	Not used
...	0	Not used	Not used
5	0	Not used	Not used
4	0	0: No detected error 1: Detected error	Loopback device is not connected.
3	0		Number of XCSR•2M12 chained is greater than 20.
2	0		Inconsistency between the number of XCSR•2M12 physically connected in series and the value set on the micro-switches. For example: <ul style="list-style-type: none"> <li>• Wrong value set on the micro-switches,</li> <li>• Value of the micro-switches changed during operations,</li> <li>• Sensor by-pass attempt,</li> <li>• Wrong wiring,</li> </ul>
1	0		XCSR•2M12 is in fail mode. In case of cable disconnection or invalid transponder detected during operations, this bit is also set to 1.
0	0	0: Open 1: Closed	State of the Chain Error contact relay.

Register 2 = Word 1. In normal operating condition, this word figures the guard states:

Bit	Default value	Value	Description
15 (MSB)	0	0: Guard opened or error detected (*) 1:Guard closed	Guard state of the XCSR•2M12 number 16
...	0		...
0	0		Guard state of the first XCSR•2M12

\*: In Error mode, Word 1 = 0

Register 3 = Word 2. In normal operating condition, this word figures the guard states:

Bit	Default value	Value	Description
15...4	0	0	Not used
3	0	0: Guard opened or error detected (*) 1:Guard closed	Guard state of the XCSR•2M12 number 20
2	0		Guard state of the XCSR•2M12 number 19
1	0		Guard state of the XCSR•2M12 number 18
0	0		Guard state of the XCSR•2M12 number 17

\*: In Error mode, Word 2 = 0

Register 4 = Word 3:

Bit	Default value	Value	Description
15...5	0	0	Not used
4	0	1...20 (dec)	Position of cable disconnection or XCSD210MDB in failure mode (for example, invalid transponder detected).
3	0		
2	0		
1	0		
0	0		

Register 5 = Word 4:

Bit	Default value	Value	Description
15...5	0	0	Not used
4	0	0...20 (dec)	Number of XCSD210MDB set on the micro-switches.
3	0		
2	0		
1	0		
0	0		

## Example

Five XCSD210MDB are connected in daisy chain to a safety control unit and a diagnostic module:

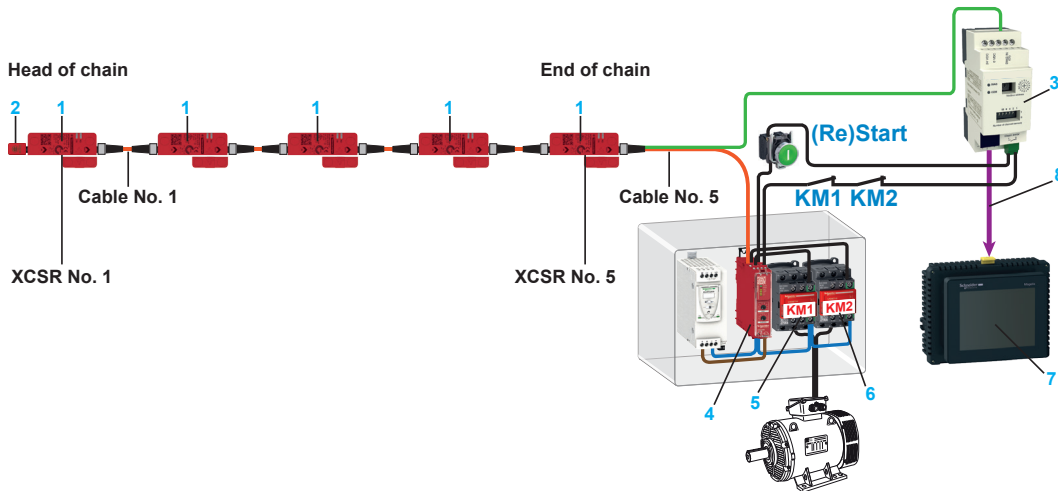

1 XCSD210MDB: XCSD210MDB RFID Safety Switch Daisy-Chain model

2 XCSRZE: Loopback device

3 XCSD210MDB: Diagnostic module

4 XPSUAK...: Safety relay

5 KM1: contactor 1 - OSSD1

6 KM2: contactor 2 - OSSD2

7 HMI

8 VW3A8306R...: 2xRJ45 Modbus cable

Example 1: the third guard is opened:

Word	Bits															
	15	14	13	12	11	10	9	8	7	6	5	4	3	2	1	0
0	0											0	0	0	0	1
1	0	0	0	0	0	0	0	0	0	0	0	1	1	0	1	1
2	0											0	0	0	0	
3	0											0	0	0	0	0
4	0											0	0	1	0	1
OSSD												O- FF	O- FF	O- FF	ON	ON

Example 2: the fourth cable is disconnected:

Word	Bits															
	15	14	13	12	11	10	9	8	7	6	5	4	3	2	1	0
0	0											0	0	0	1	0
1	0	0	0	0	0	0	0	0	0	0	0	0	0	0	0	0
2	0											0	0	0	0	
3	0											0	0	1	0	0
4	0											0	0	1	0	1
OSSD												O- FF	O- FF	O- FF	O- FF	O- FF

Example 3: the loopback device is not connected:

Word	Bits															
	15	14	13	12	11	10	9	8	7	6	5	4	3	2	1	0
0	0											1	0	0	0	0
1	0	0	0	0	0	0	0	0	0	0	0	0	0	0	0	0
2	0											0	0	0	0	
3	0											0	0	0	0	0
4	0											0	0	1	0	1
OSSD												O- FF	O- FF	O- FF	O- FF	O- FF

Example 4: the number of XCSR+2M12 connected in serial is different than the one configured on the micro-switches (sensor by-pass or wrong configuration):

Word	Bits															
	15	14	13	12	11	10	9	8	7	6	5	4	3	2	1	0
0	0											0	0	1	0	0
1	0	0	0	0	0	0	0	0	0	0	0	0	0	0	0	0
2	0											0	0	0	0	
3	0											0	0	0	0	0
4	0											0	0	1	1	0
OSSD												ON	ON	ON	ON	ON

If the Chain Error contact is wired as External Start Condition, the system will not start after a power-up (and a restart command if required) until the inconsistency on the number of switches present/configured has been cleared.

# Operating

## Operating Hardware Installation

Installation of the diagnostic module (module not connected and not powered):

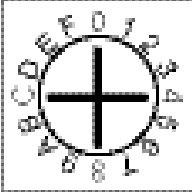
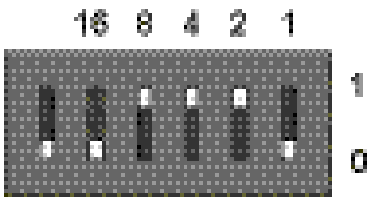
Step	Action
1	<p>Configure the Modbus server address with the rotary switch (the address 0 is reserved).</p>  <p>You can set the Modbus address at any time and during any operating mode. There are 15 possible Modbus addresses (1...15).</p>
2	<p>Configure the number of XCSRC•2M12 present on the safety chain with the micro-switches:</p>  <p>This value must be set before powering-up the product. Example: the value set on the picture above is 14(dec), binary code equal to: 1110 = 2<sup>3</sup> + 2<sup>2</sup> + 2<sup>1</sup>.</p>
3	<a href="#">Wire the diagnostic module, page 68 .</a>
4	Power up the module.

The diagnostic module goes to Initialization state.

## Initialization State

During this state:

- The two LEDs are orange
- The contact Chain Error is opened

At power-up, the following initialization steps are automatically performed:

Step	Action	Description
1	Acquisition of the number of XCSRC•2M12 on the chain set on the micro-switches.	<p>NB: Once in operation, the micro-switches cannot be changed. The micro-switch changes are taken into account after a power cycle only. If you change this value, the diagnostic module falls into error. This error is blocking and a restart is mandatory.</p> <p>To change this value, power off the module, reconfigure it, and then restart.</p>
2	Acquisition of the Modbus server address set previously on the rotary switch.	You can set the Modbus address at any time and during any operating mode.
3	Modbus register initializations (by default)	-
4	The diagnostic module goes to Run state.	-

## Run State

This step follows the initialization step of diagnostic function and Modbus function.

At each reception of diagnostic data, Modbus registers are updated.

### **Diagnostic function:**

If no diagnostic frame is received within a timeout of 3 s or diagnostic frame are incorrect, the diagnostic module enters in error state.

The error suppression and a new start are necessary to leave the error state.

The reception of a diagnostic frame is indicated by flashing of diagnostic LED.

For more details, refer to the [Diagnostic LED description, page 70](#).

### **Modbus function** (Modbus line configuration detection):

The reception of a Modbus frame is indicated by flashing of Modbus LED.

In case of Modbus communication detected error, no restart is required. If the detected error is canceled, the communication resumes automatically.

A Modbus detected error never affects the state of Chain Error contact.

For more details, refer to the [Modbus LEDs description, page 70](#).

## Characteristics

### Conformity/Approvals

This table provides the standards and approvals:

<b>Conforming to standards</b>	IEC 60947-1, IEC 61326-2-1 UL 60947-1, CSA C22.2 No. 60947-1
<b>Approvals</b>	CE, cULus, UKCA

### Product Performances Requirements

Electrical characteristics:

Characteristics	Value
Power supply	The power supply must meet requirements of IEC 60204-1 relative to SELV/PELV power supply.
Operating supply voltage	+24 Vdc (+10%, -20%) = [+19.2 Vdc, +26.4 Vdc]
Power consumption	≤ 300 mA
Power on delay	< 5 s
Reverse polarity protection	Yes (excluding RJ45)
Input signal	Compatible with XCSRC•2M12 diagnostic signal
Protection	External fuse

Interface:

Characteristics	Detail	Value
Relay	Type	Mechanical
	Current	<200 mA
	Voltage	≤+24 Vdc
	Ton	1 ms / 3 ms
	Toff	1 ms / 3 ms
Output power (RJ45)	Voltage	+5 Vdc (+/- 6%) = +4.7 Vdc,... +5.3 Vdc,
	Current	<200 mA (protected)
Modbus	Baudrate	Refer to <a href="#">Modbus settings accepted, page 71</a> .
	Parity	
	Registers	
	Pull out resistance	Pull up: 562 Ω, pull down: 562 Ω

Electromagnetic compatibility:

Characteristics	Conform to
EMC immunity withstands	IEC 61326-2-1

## Mechanical characteristics:

Characteristics	Detail	Value
Housing material	-	Polycarbonate
Display	Type	Two three-color LEDs (red, orange, green)
Degree of protection	-	IP20
Shock resistance	-	15 gn / 11 ms Conforming IEC 60068-2-27
Vibration resistance	-	Conforming IEC 60068-2-6 +/- 3.5 mm (0.138 in) 5...8.4 Hz 1 g (8.4...150 Hz)
Impact	-	IK04
Temperatures	Operating	0...60 °C (32...140 °F)
	Storage	-40...+85 °C (-40...185 °F)
Humidity	-	<95% without condensation

# Glossary

## A

### ANSI

American National Standards Institute. The administrator and coordinator of the U.S. private sector standardization system.

### AWG

(American wire gauge) The standard that specifies wire section sizes in North America.

## C

### Category (Cat.)

Describe the safety-related parts of control systems performance in relation to their ability to resist to failures and resulting behavior in case of failure. Five categories are defined depending on design architectures.

### Control-reliable

The device, system, or interface shall be designed, constructed, and installed such that a single component failure within the device, interface, or system shall not prevent normal stopping action from taking place, but shall prevent a successive machine cycle (ANSI B11.191).

## E

### EDM/MPCE (External Device Monitoring/Machine Primary Control Element Monitoring)

A means by which the XCSR RFID switch monitors the state of external control devices.

### EMC

(*ElectroMagnetic Compatibility*)

## I

### IEC

(*International Electrotechnical Commission*) A non-profit and non-governmental international standards organization that prepares and publishes international standards for electrical, electronic, and related technologies.

### IP 67

(*ingress protection*) The protection classification according to IEC 60529. IP 67 modules are protected against ingress of dust, contact, and water up to an immersion depth of 1 m.

### IP69K

Protection classification according to DIN 40050 relative to high pressure cleaning test.

## M

### Mission Time

Period of time covering the intended use of a safety related system.

**O****Off state**

The state in which the output circuit is interrupted (open) and does not allow current to flow.

**On state**

The state in which the output circuit is complete (closed) and allows the flow of current.

**Output Safety Switching Device (OSSD)**

The component of the XCSR RFID switch connected to the machine control system which, when the guard door is open, responds by going to Off state. This is also known as a safety output.

**P****Performance level (PL)**

Ability of safety-related parts of control systems (SRP/CS) to perform a safety function in order to achieve the required risk reduction.

**Probability of Dangerous Failure per Hour**

(PFH<sub>D</sub>) Average probability of dangerous failure per hour for high demand mode of operation.

**R****Response times**

Refer to [Definition of Characteristic Times, page 13](#).

**S****Safety Integrated Level (SIL)**

The failure mode evaluation based on the risk assessment in accordance with IEC 61508. Estimation of the required SIL is performed for each safety-related control function (SRCF) and represent the levels that the control-command must respect according to the known risk factors associated with the installation. Level 3 is the highest and Level 1 the lowest level.

**Safety Integrated Level Claim Limit (SILCL)**

Maximum SIL that can be claimed for safety function of any subsystem.

**Sao (Assured Operating Sensing Distance)**

$S_{ao}$  is the distance from the sensing face within which the presence of the specified target is correctly detected under all specified environmental conditions and manufacturing tolerances

**Sar (Assured Release Sensing Distance)**

$S_{ar}$  is the distance from the sensing face beyond which the absence of the specified target is correctly detected under all specified environmental conditions and manufacturing tolerances

**SELV**

*(safety extra low voltage)* A system that follows IEC 61140 guidelines for power supplies is protected in such a way that voltage between any 2 accessible parts (or between 1 accessible part and the PE terminal for class 1 equipment) does not exceed a specified value under normal conditions or under inoperable conditions.

[www.telemecaniquesensors.com](http://www.telemecaniquesensors.com)

The information provided in this catalogue contains description of products sold by TMSS France, its subsidiaries and other affiliated companies ('Offer') with technical specifications and technical characteristics of the performance of the corresponding Offer.

The content of this document is subject to revision at any time without notice due to continued progress in methodology, design and manufacturing.

To the extent permitted by applicable law, no responsibility or liability is assumed by TMSS France, its subsidiaries and other affiliated companies for any type of damage arising out of or in connexion with (a) informational content of this catalogue not conforming with or exceeding the technical specifications, or (b) any error contained in this catalogue, or (c) any use, decision, act or omission made or taken on the basis of or in reliance on any information contained or referred to in this catalogue.

**NEITHER TMSS FRANCE, ITS SUBSIDIARIES, NOR ITS OTHER AFFILIATES, AS THE CASE MAYBE, MAKE NO WARRANTY OR REPRESENTATION OF ANY KIND, WHETHER EXPRESS OR IMPLIED, AS TO WHETHER THIS CATALOGUE OR ANY INFORMATION CONTAINED THEREIN SUCH AS PRODUCTS WILL MEET REQUIREMENTS, EXPECTATIONS OR PURPOSE OF ANY PERSON MAKING USE THEREOF.**

Telemecanique™ Sensors is a trademark of Schneider Electric Industries SAS used under license by TMSS France. Any other brands or trademarks referred to in this catalogue are property of TMSS France or, as the case may be, of its subsidiaries or other affiliated companies. All other brands are trademarks of their respective owners.

This catalogue and its content are protected under applicable copyright laws and provided for informative use only.

No part of this catalogue may be reproduced or transmitted in any form or by any means (electronic, mechanical, photocopying, recording, or otherwise), for any purpose, without the prior written permission of TMSS France. Copyright, intellectual, and all other proprietary rights in the content of this catalogue (including but not limited to audio, video, text, and photographs) rests with TMSS France, its subsidiaries, and other affiliated companies or its licensors. All rights in such content not expressly granted herein are reserved. No rights of any kind are licensed or assigned or shall otherwise pass to persons accessing this information.

As standards, specifications and design change from time to time, please ask for confirmation of the information given in this publication.

©2025, TMSS France, All Rights Reserved.

**TMSS France SAS**

Share capital: 366 931 214 €  
Tour Eqho, 2 avenue Gambetta  
92400 Courbevoie – France  
908 125 255 RCS Nanterre

October 2025 - V1.0

TESEUG000268EN