

# XUSL2E/XUSL4E

## Type 2 and Type 4 Safety Light Curtains

### User Manual

Original instructions



# Legal Information

The information provided in this guide contains description of products sold by TMSS France, its subsidiaries and other affiliated companies ('Offer') with technical specifications and technical characteristics of the performance of the corresponding Offer.

The content of this document is subject to revision at any time without notice due to continued progress in methodology, design and manufacturing.

To the extent permitted by applicable law, no responsibility or liability is assumed by TMSS France, its subsidiaries and other affiliated companies for any type of damage arising out of or in connexion with (a) informational content of this guide not conforming with or exceeding the technical specifications, or (b) any error contained in this guide, or (c) any use, decision, act or omission made or taken on the basis of or in reliance on any information contained or referred to in this guide.

**NEITHER TMSS FRANCE, ITS SUBSIDIARIES, NOR ITS OTHER AFFILIATES, AS THE CASE MAYBE, MAKE NO WARRANTY OR REPRESENTATION OF ANY KIND, WHETHER EXPRESS OR IMPLIED, AS TO WHETHER THIS GUIDE OR ANY INFORMATION CONTAINED THEREIN SUCH AS PRODUCTS WILL MEET REQUIREMENTS, EXPECTATIONS OR PURPOSE OF ANY PERSON MAKING USE THEREOF.**

Telemecanique™ Sensors is a trademark of Schneider Electric Industries SAS used under license by TMSS France. Any other brands or trademarks referred to in this guide are property of TMSS France or, as the case may be, of its subsidiaries or other affiliated companies. All other brands are trademarks of their respective owners.

This guide and its content are protected under applicable copyright laws and provided for informative use only.

No part of this guide may be reproduced or transmitted in any form or by any means (electronic, mechanical, photocopying, recording, or otherwise), for any purpose, without the prior written permission of TMSS France. Copyright, intellectual, and all other proprietary rights in the content of this guide (including but not limited to audio, video, text, and photographs) rests with TMSS France, its subsidiaries, and other affiliated companies or its licensors. All rights in such content not expressly granted herein are reserved. No rights of any kind are licensed or assigned or shall otherwise pass to persons accessing this information.

# Table of Contents

Safety Information.....	5
About the Book .....	6
General .....	7
Safety Requirements .....	8
Safety Requirements .....	8
Product Description .....	10
General Information.....	10
XUSL2E/XUSL4E General Description .....	11
How a Safety Light Curtain Works?.....	12
Resolution.....	13
Protected Height.....	14
Response Time.....	15
Safety Types.....	16
Risk Assessment .....	18
Safety Light Curtain Functions .....	20
Operating Modes .....	20
External Device Monitoring (EDM) or Machine Primary Control Element (MPCE) Monitoring.....	22
Test Function .....	23
Maximum Sensing Distance Selection .....	24
Operating States.....	25
Cascaded Function (XUSL4E) .....	27
Muting.....	28
System Components .....	30
System Components Identification .....	30
XUSL2E/XUSL4E Features.....	32
Preinstallation Considerations .....	33
Safe Mounting Distance.....	34
European Safe Mounting Distance Formula.....	35
Detection Zone Approaches .....	37
U.S. Safe Distance Formula .....	42
Additional Mounting Considerations .....	45
Reflective Surface Interference .....	45
Test Rod Procedure.....	49
Additional Guarding .....	50
Multiple Systems.....	51
Installation, Wiring, and Startup .....	53
Installation.....	54
Mounting the Light Curtain.....	55
Wiring.....	58
Electrical Connections .....	59

Connection Schematics.....	62
Start Up.....	68
User Interface .....	68
Aligning the Transmitter and Receiver.....	70
Troubleshooting .....	72
Receiver and Transmitter Troubleshooting.....	73
Transmitter Troubleshooting .....	73
Receiver Troubleshooting.....	74
Technical Characteristics .....	75
Technical Characteristics.....	76
Light Curtain Specifications.....	76
Response Time and Safety Related Data .....	80
Total PFHD Calculation .....	85
Dimensions and Weights.....	86
Accessories .....	88
Appendices .....	103
Checkout and Test Procedures.....	104
Checkout Procedure.....	105
Test Procedure .....	107
Glossary.....	108

# Safety Information

## Important Information

Read these instructions carefully, and look at the equipment to become familiar with the device before trying to install, operate, service, or maintain it. The following special messages may appear throughout this documentation or on the equipment to warn of potential hazards or to call attention to information that clarifies or simplifies a procedure.



The addition of this symbol to a "Danger" or "Warning" safety label indicates that an electrical hazard exists which will result in personal injury if the instructions are not followed.



This is the safety alert symbol. It is used to alert you to potential personal injury hazards. Obey all safety messages that follow this symbol to avoid possible injury or death.

### **DANGER**

**DANGER** indicates a hazardous situation which, if not avoided, **will result in** death or serious injury.

### **WARNING**

**WARNING** indicates a hazardous situation which, if not avoided, **could result in** death or serious injury.

### **CAUTION**

**CAUTION** indicates a hazardous situation which, if not avoided, **could result in** minor or moderate injury.

### **NOTICE**

**NOTICE** is used to address practices not related to physical injury.

## Please Note

Our product should be installed, operated and maintained only by qualified personnel. Neither TMSS France nor any of its subsidiaries or other affiliated companies shall be responsible or liable for any consequences arising out of the use of this material.

A qualified person is one who has skills and knowledge related to the construction and operation of electrical equipment and its installation, and has received safety training to recognize and avoid the hazards involved.

# About the Book

## Document Scope

This manual describes the features, installation, wiring, usage, and troubleshooting of the XU IO-Link and the communication system IO-Link.

## Validity Note

The technical characteristics of the device(s) described in this manual also appear online.

To access this information online:

Step	Action
1	Go to <a href="http://www.telemecaniquesensors.com">www.telemecaniquesensors.com</a> .
2	In the <b>Search</b> box, type the model number of a product or the name of a product range. Do not include blank spaces in the model number/product range.
3	If more than one model number appears in the <b>Products</b> search results, click on the model number that interests you.
4	To save or print a data sheet as a .pdf file, click <b>Download product datasheet</b> .

The characteristics that are described in the present document should be the same as those characteristics that appear online. In line with our policy of constant improvement, we may revise content over time to improve clarity and accuracy. If you see a difference between the document and online information, use the online information as your reference.

## QR Code

A QR code including the Telemecanique Sensors web address is present on the safety light curtain label. Technical documents are available in various languages in this website.



## Related Documents

Title of Documentation	Reference Number
EAV65900_04	XUSL4E/XUSL2E***
EAV75016_05	XUSL ***WC / XUSL ***WH - IP69K Enclosure

You can download these technical publications and other technical information from our website at [www.telemecaniquesensors.com](http://www.telemecaniquesensors.com).

## User Comments

We welcome your comments about this document. You can reach us through the customer support page on your local TeSensors website.

# General

## What's in This Part

Safety Requirements .....	10
Product Description .....	12

## Overview

This part provides detailed information about the safety requirements and product description.

# Safety Requirements

## What's in This Part

Safety Requirements ..... 1

## Overview

This chapter describes the safety requirements in detail.

## Safety Requirements

### Precautions

<b>⚠ WARNING</b>
<p><b>IMPROPER SETUP OR INSTALLATION</b></p> <ul style="list-style-type: none"> <li>• This equipment must only be installed and serviced by qualified personnel.</li> <li>• Read, understand and follow the compliance below before installing the XUSL2E XUDSL4E safely light curtain</li> </ul> <p><b>Failure to follow these instructions can result in death, serious injury, or equipment damage.</b></p>

## Meeting Full Compliance

The compliance of a machine and the XUSL2E/XUSL4E light curtain system with safety regulations, depends on the proper application, installation, maintenance, and operation of the XUSL2E/XUSL4E light curtain system. These are responsibilities of the purchaser, installer, and employer.

The employer is responsible for selecting and training the personnel necessary to properly install, operate, and maintain the machine and its safeguarding systems. The XUSL2E/XUSL4E system must only be installed, checked, and maintained by a qualified person. A qualified person is defined as “a person or persons who, by possession of a recognized degree or certificate of professional training, or who, by extensive knowledge, training and experience, has successfully demonstrated the ability to solve problems relating to the subject matter and work” (ANSI B30.2).

To use the XUSL2E/XUSL4E light curtain system, the given requirements must be met:

- The guarded machine must be able to stop anywhere in its cycle. Do not use a safety light curtain on a press with a full-revolution clutch.
- The guarded machine must not present a hazard from flying parts.
- The guarded machine must have a consistent stopping time and adequate control mechanisms.
- Heavy smoke, particulate matter, and corrosives may degrade the efficiency of a safety light curtain. Electro-sensitive protective equipment is not suitable for outdoor (1), explosive atmospheres and under water applications. Do not use XUSL2E/XUSL4E safety light curtains in this type of environment.(1) Electro-sensitive protective equipments are not suitable for outdoor use without additional suitable protection.
- All applicable governmental and local rules, codes, and regulations must be satisfied. This is the user and employer responsibility.

- All safety-related machine control elements must be designed so that an alarm in the control logic or the control circuit breakdown does not lead to a XUSL2E/XUSL4E light curtain system failure.
- The proper functioning of the XUSL2E/XUSL4E safety light curtains and its operating line must be checked on a regular basis based on the level of security required by the application (for example, number of operations, level of environmental pollution, etc.).
- Perform the [Test procedure, page 106](#) during installation and after maintenance or adjustment. As well as in case of any modification of the machine controls, tooling, dies, machine or of the light curtain system.
- Perform only the test and diagnostic procedures outlined in this manual.
- Follow all procedures in this manual for proper operation of the XUSL2E/XUSL4E light curtain system.
- All safety-related machine control circuit elements, including pneumatic, electric, or hydraulic controls must be control-reliable.
- Electro-sensitive protective equipment (ESPE) must not be used as a lock-out device.
- Additional measures may be necessary to ensure that the ESPE does not fail to danger when other forms of light radiation are present in a particular application (for example, use of cableless control devices on cranes, radiation from weld spatter, or effects from stroboscopic lights).

The enforcement of these requirements is beyond the control of TMSS France. The employer has the sole responsibility to follow the preceding requirements and any other procedures, conditions, and requirements specific to the machinery.

## Product Support

For more information about products and services in your country, visit [www.telemecaniquesensors.com](http://www.telemecaniquesensors.com).

# Product Description

## What's in This Chapter

General Information .....	12
Safety Light Curtain Functions .....	22
System Components .....	32

## Overview

This chapter describes the general information, safety light curtain functions, and system components.

## General Information

### Overview

This section describes general information of the safety light curtain.

## XUSL2E/XUSL4E General Description

### Overview

The XUSL2E/XUSL4E light curtain system is used where personnel protection is required. The basic applications include finger, hand, and body detection around hazardous equipments such as:

- Robotic work cells
- Transfer lines
- Assembly lines
- Turret punch presses
- Palletizers
- Welding stations
- Roll handling equipments
- Coilers and uncoilers
- Automated equipments
- Machine tools
- Food and beverage equipments
- Packaging machines
- Mechanical and hydraulic presses

## How a Safety Light Curtain Works?

### General Description

A safety light curtain system is an optical infrared beam guarding system that is used to ensure the security of operators in the vicinity of hazardous areas, by stopping the movement of parts in this area when at least one of the light beams is interrupted. This system consists of a microprocessor-controlled receiver and transmitter facing each other and that are not physically interconnected. An array of infrared LEDs is located in the transmitter that emits infrared beams to photo-sensitive cells array located in the receiver. The infrared LEDs are triggered one after the other and the receiver photo-cells are synchronized to detect only the corresponding beam.

When the detection zone is not interrupted, the two redundant safety outputs are active (ON state) and enables the equipment that is connected downstream to work properly. When an object of a size greater or equal to the resolution interrupts at least one beam, the two redundant safety outputs switch OFF (OFF state) in order to stop the machine.

This figure describes the Safety light curtain:

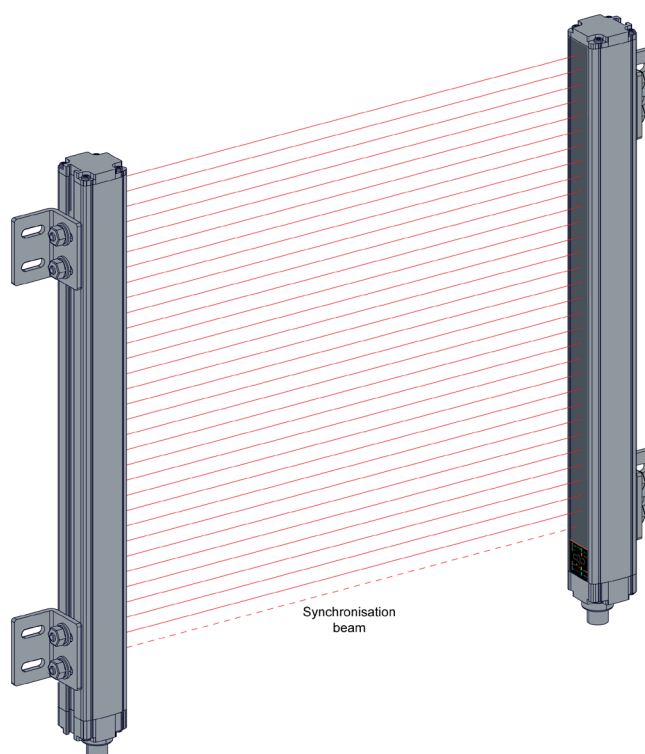

## Resolution

### General Description

Resolution (**R**) is also called Minimum Object Sensitivity (**MOS**) or Detection Capability. This is the smallest diameter (object) that a safety light curtain system is capable of detecting with absolute certainty.

This figure describes the resolution of the safety light curtain system:

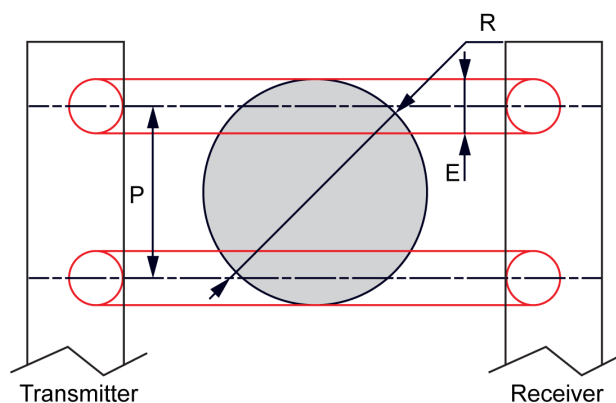

$$R = P + E$$

where:

**P** = distance between the axis of two adjacent beams.

**E** = diameter of the beams.

	<b>P</b>	<b>E</b>
Finger detection	10 mm (0.39 in)	3.5 mm (0.14 in)
Hand detection	20 mm (0.79 in)	9 mm (0.35 in)
Body detection 2-3-4 beams	500-400-300 mm (19.68-15.75-11.81 in)	9 mm (0.35 in)

**NOTE** : The beam diameter values are approximative, because they can vary depending on several factors (for example, the distance between transmitter and receiver).

## Protected Height

### General Description

The protected height (**Hp**) is the zone (or height), for which an object (whose diameter is at least equal to the resolution **R**) is detected with absolute certainty.

This figure describes the protected height for the safety light curtain:

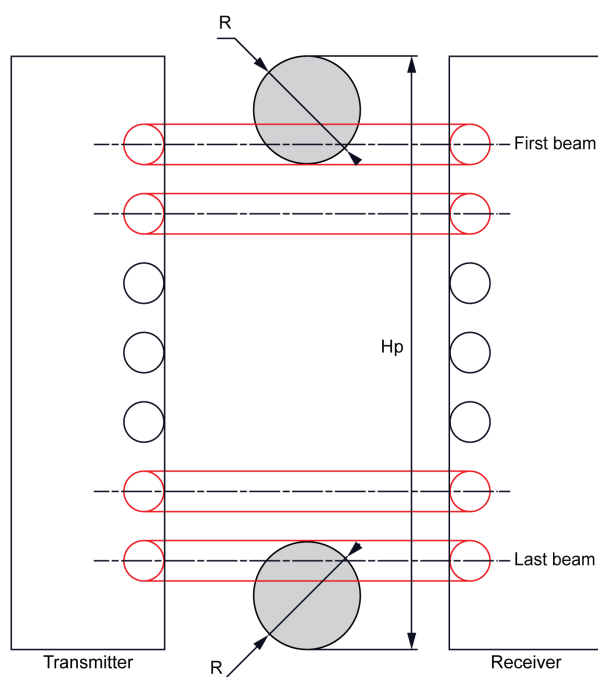

## Response Time

### General Description

European standard ISO 13855 incorporates the various aspects of response time in the formula for calculating the [minimum safe distance, page 35](#).

The total response time (**T**) corresponding to the overall system stopping performance is calculated by the given formula:

$$T = t1 + t2$$

where:

**t1** = Response time of the protection device (in second). This is the time indicated for the XUSL2E and XUSL4E ranges. It is the total time between detection by the device and switching of the output component. Refer to the [Response Time and Safety Related Data, page 79](#).

**t2** = Stopping time of the machine (in seconds): maximum time required to terminate the hazardous machine function after the output signal from the safeguard achieves the OFF-state. This information is supplied by the machine manufacturer. The response time of the control system of the machine is included in **t2**.

## Safety Types

### General Description

There are significant differences between XUSL2E (Type 2) and XUSL4E (Type 4) that are necessary to be highlighted. The type 2 and type 4 are defined by the standard IEC 61496-1.

### XUSL2E (Type 2)

The type 2 safety light curtains test their internal circuits periodically (every 500 ms for XUSL2E). If a failure appears between the two test sequences, it will be detected only after the next test. The XUSL2E device has a reduced-capability (for example, wider aperture angle and longer response time than a type 4 device). The design of these light curtains is suitable for applications where the risk analysis demonstrates a minor injury risk to operators. These light curtains are less expensive than type 4 due to their simplified architecture. The type 2 safety light curtain systems are available only for hand and body detection.

The XUSL2E light curtains are compliant with type 2 (IEC 61496-1), SIL 1 (IEC 61508) - SILCL1 (IEC 62061), and PL c - Cat. 2 (ISO 13849-1).

This figure describes the operating fault detected for the type 2 light curtain:

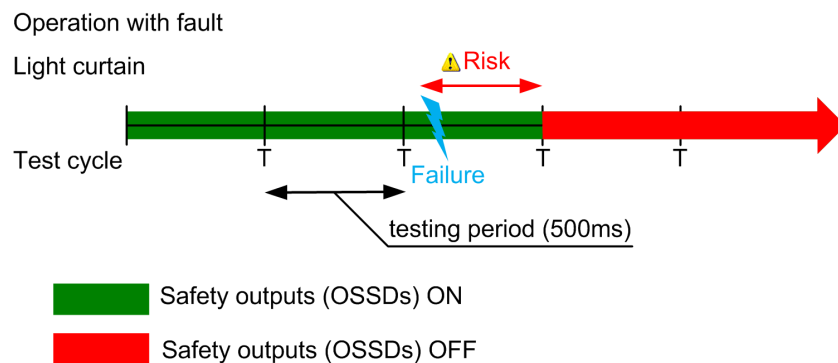

## XUSL4E (Type 4)

Unlike type 2, the type 4 design is based on redundant automatic cross-checking architecture. This architecture enables immediate failure detection within the response time. The type 4 light curtains are suitable for applications where the risk analysis demonstrates a moderate or severe injury risk to operators. The type 4 safety light curtain systems are available for finger, hand, and body detection. The XUSL4E device provides a shorter response time and narrower aperture angle than XUSL2E.

The XUSL4E light curtains are compliant with type 4 (IEC 61496-1), SIL 3 (IEC 61508) - SILCL3 (IEC 62061), and PLe - Cat. 4 (ISO 13849-1).

This figure describes the operating fault detected for the type 4 light curtain:

<b>⚠ WARNING</b>
<b>IMPROPER TYPE UTILIZATION</b> <ul style="list-style-type: none"><li>• It is the responsibility of the user or integrator to check whether the use of type 2 or type 4 safety light curtain system is consistent with the application risk assessment.</li><li>• To choose the right product for your application, perform a risk assessment.</li></ul> <b>Failure to follow these instructions can result in death, serious injury, or equipment damage.</b>

## Risk Assessment

### General Description

Risk assessment and risk reduction are **iterative process** described in ISO 12100, IEC 61496-1, IEC 61508 & IEC 62061 (SIL), and IEC 13849-1 (PL). There are various techniques for risk assessment, and not one of it can be considered as the right way to perform risk assessment. The standard specifies some general principles but does not specify exactly what has to be done in each case.

For safety related data, refer to [Response Time and Safety Related Data, page 79](#).

This flowchart describes the risk assessment process:

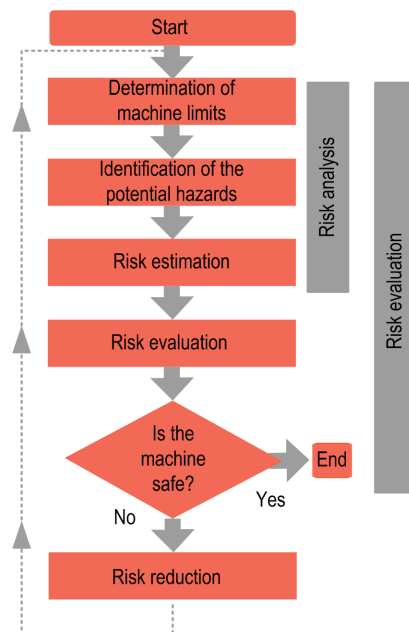

Essential steps for risk assessment are the following:

- Define tolerable risk level.
- Identify hazards.
- Analyze hazards.
- Determine whether the risks are below an acceptable level.
- Define protection measures if risks are above a tolerable level.
- Check whether protection measures taken lead to an effective risk reduction (Iterative process).

This figure describes the elements of risk to take into account for the risk estimation:

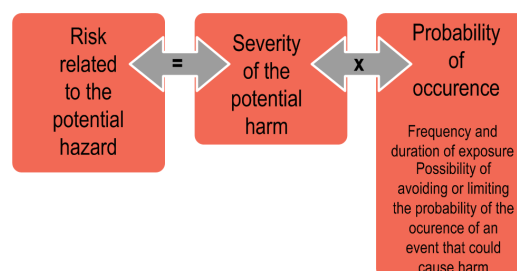

For more information, refer to:

[www.se.com/ww/en/download/document/DIA4ED1100102EN](http://www.se.com/ww/en/download/document/DIA4ED1100102EN).

## Reference Standards

The following table describes the main reference standards:

Standard	Risk assessment	Description
ISO 12100	Risk assessment and risk reduction	Safety of machinery.General principles for design.Risk assessment and risk reduction.
Standard	Safety level	Description
IEC 13849-1	Performance level (PL)	Safety-related part of control system.General principles for design.
	Category (Cat)	
IEC 61508	Safety integrity level (SIL)	Functional safety of electrical/ electronic/programmable electronic safety-related systems.
IEC 62061	Safety integrity level claim limit (SILCL)	Safety of machinery.Functional safety of safety-related electrical, electronic, and programmable electronic control systems.
IEC 61496-1	Type	Electro-sensitive protective equipment.General requirements and tests.Particular requirements for equipment using active opto-electronic protective devices (AOPDs).

# Safety Light Curtain Functions

## Overview

This section describes the various functions of the safety light curtain.

## Operating Modes

### Introduction

The operating mode determines the start-up and operating behavior of the XUSL2E/XUSL4E light curtain system. The operating mode descriptions in this section are derived from the [operating state definitions, page 24](#).

### Automatic Start

In this mode, the system enters the Run state during startup without operator intervention, as long as the detection zone is not blocked. When the XUSL2E/XUSL4E light curtain system is powered up, its safety outputs are OFF. If the detection zone is not obstructed and no faults are detected, it enters the [Run state, page 25](#) after 2 seconds and the two safety outputs switch to ON state. In this state, when the XUSL2E/XUSL4E light curtain system senses an object entering the detection zone, the machine changes from Run state to [Stop state, page 26](#) (the two safety outputs switch to OFF state), and remains in the Stop state until the obstruction is removed. The XUSL2E/XUSL4E light curtain system automatically changes from Stop state to Run state when the detection zone is cleared without any fault detected.

#### **⚠ WARNING**

##### **IMPROPER AUTOMATIC START UTILIZATION**

The manual Start/Restart is required in most Safety applications. If you use the automatic start function, check that this automatic start mode is compatible with risk assessment performed for the application

**Failure to follow these instructions can result in death, serious injury, or equipment damage.**

### Manual Start/Restart

When the XUSL2E/XUSL4E light curtain system is powered up, its safety outputs are OFF. If no faults are detected after the first up time, it enters the Start/Restart state. To enter the Run state, the detection zone must be clear and no faults are detected, and the operator must press and release "monitored start" the **Start** button. If the XUSL2E/XUSL4E light curtain system senses an object entering the detection zone when it is in Run state, the Safety light curtain changes to Stop state and the safety outputs change from ON to OFF state.

After the obstruction is removed from the detection zone, the XUSL2E/XUSL4E light curtain system changes to the Start/Restart state and the safety outputs stay at OFF state. To enter the Run state, the operator must press and release the **Start** button. If any obstruction is still present in the detection zone when you press and release the **Start** button, the XUSL2E/XUSL4E light curtain system remains in the Stop state and the safety outputs remain in OFF state. If the detection zone is clear after the release of the **Start** button and no faults are detected, the XUSL2E/XUSL4E light curtain system enters Run state and the safety outputs switch to ON state.

To select automatic or manual Start/Restart, refer to the [wiring instructions, page 61](#).

### **WARNING**

#### **UNINTENDED EQUIPMENT OPERATION**

The manual Start/Restart is mandatory :

- If safety device controls an aperture to protect a hazardous area.
- If a person remains in the hazardous area without being detected after having passed through the aperture («trip device» according to IEC 61496-1).

**Failure to follow these instructions can result in death, serious injury, or equipment damage.**

### **WARNING**

#### **UNINTENDED EQUIPMENT OPERATION**

The Restart command must be installed outside the hazardous area in such way that the whole working and hazardous areas are observable. You must not access the Start/Restart command inside the hazard area.

**Failure to follow these instructions can result in death, serious injury, or equipment damage.**

### **NOTICE**

#### **UNINTENDED EQUIPMENT OPERATION**

- The Start/Restart command is effective after the operator has pressed and released the **Start** button which means a transition sequence 0 Vdc -> 24 Vdc -> 0 Vdc is on the start command.
- The duration of this sequence must be between 100 ms and 5 s.

**Failure to follow these instructions can result in equipment damage.**

## External Device Monitoring (EDM) or Machine Primary Control Element (MPCE) Monitoring

### General Description

EDM monitoring is an important safety function.

The EDM monitors the XUSL2E/XUSL4E light curtain system interface to the guarded machine to:

- Confirm that the external devices such as switching devices like contactors are responding correctly to the XUSL2E/XUSL4E light curtain outputs.
- Detect any inconsistency between the two external devices (i.e. control relays) which could prevent a stop signal from reaching the machine primary control elements (for example, power contactors or electrovalve relays).

The EDM controls the external contactors K1/K2 connected to the two OSSDs. To achieve this, normally closed contacts of the external contactors (connected in series) are monitored. The control of the correct switching of K1 and K2 is performed 300 ms after the real command of the OSSDs.

To perform this function, the contactors K1/K2 must have:

- Normally closed mirror contact, according to IEC 60947-4-1 (Annex F) for power contactors.
- Linked contacts (or force-guided contacts), according to IEC 60947-5-1 (Annex L) or IEC 61810-3 for auxiliary contactors or control relays.

To manage the EDM function, refer to [wiring instructions, page 61](#).

## Test Function

### General Description

Few applications require the machine guarding system to be tested by the machine controller during a non-hazardous portion of the machine cycle. This is to verify that the guarding system is functioning properly. To trigger the test functions connect pins 2 and 4 on the transmitter at 0 Vdc (by means of potential free contact).

When the transmitter senses a 0 Vdc on these pins, a beam blocked state is simulated (as if the protected zone was occupied) and the receiver enters the Stop state. The beam blocked state is simulated as long as the pins 2 and 4 are connected to 0 Vdc. An external control unit (for example, a PLC) can thus check the correct operation of the entire system, by monitoring the connected downstream equipment.

#### ***NOTICE***

##### **UNINTENDED EQUIPMENT OPERATION**

The test command must be at least 4 ms.

**Failure to follow these instructions can result in equipment damage.**

## Maximum Sensing Distance Selection

### General Description

Two different maximum sensing distances (low range and high range) can be selected for every safety light curtain (XUSL4E and XUSL2E).

This table displays the sensing range selection:

Models	Sensing range selection	XUSL2E		XUSL4E		
		Hand	Body	Finger	Hand	Body
Standard range	Low range: 0...3 m High range: 1...6 m	–	–	x	–	–
Standard range	Low range: 0...4 m High range: 0...12 m	x	x	–	x	x
Long range	Low range: 0...10 m High range: 3...20 m	–	–	–	x	x

To select the Low range and High range, refer to the [wiring instruction for Pin 2 and Pin 4, page 59](#).

# Operating States

## Introduction

This figure describes the transmitter and receiver operating states:

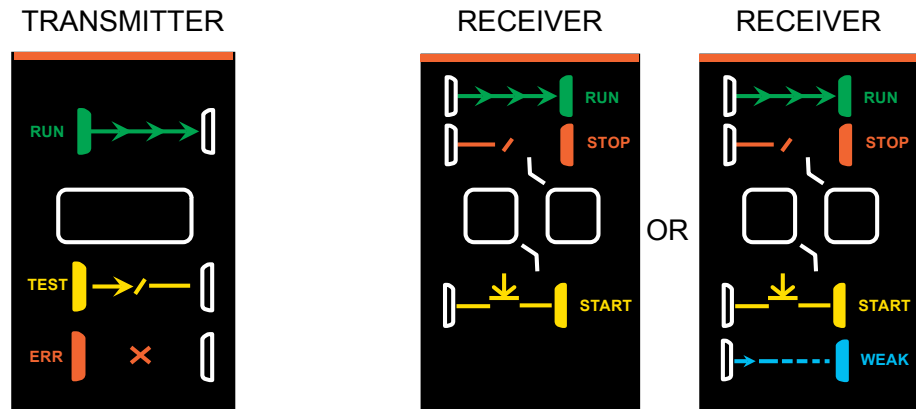





## Transmitter Operating State

This table describes the transmitter operating states of the XUSL2E/XUSL4E safety light curtains:

Operating State	LED Indication	Figure	Description
Run state	Green		Normal operating state. The Run indicator is lit. The transmitter is operational.
Test state	Orange		The indicator is lit when the <a href="#">test command is activated, page 22</a> .
Error state	Red flashes		This state occurs when the system is in fail conditions. In this state, the two receiver safety outputs switch to the OFF state and the red transmitter indicator flashes.  When the system is in error state, the guarded machine is not allowed to operate.  For meaning of the red flashes, refer to <a href="#">Troubleshooting, page 71</a> .
Power-on test state	Red		This state occurs during the power-on and initial test phases.

## Receiver Operating States

This table describes the receiver operating states of the XUSL2E/XUSL4E safety light curtains:

Operating State	LED Indication	Figure	Description
Run state	Green		<p>Normal operating state. The two receiver safety outputs are in ON state and the green indicator is lit.</p> <p>The guarded machine is allowed to operate.</p>
Stop state	Red		<p>This state occurs when at least one beam is interrupted. The two receiver safety outputs are in OFF state and the red indicator is lit.</p> <p>The guarded machine is not allowed to operate.</p>
Error state	Red flashes		<p>This state occurs when the system is in fail condition. In this state, the two receiver safety outputs switch to the OFF state and the red receiver indicator flashes.</p> <p>When the receiver is in this state, the guarded machine is not allowed to operate.</p> <p>For meaning of the red flashes, refer to <a href="#">Troubleshooting, page 71</a>.</p>
Start/Restart state	Yellow		<p>This state occurs when the system is in <a href="#">Manual Start/Restart mode, page 20</a>. The two receiver safety outputs are in the OFF state and the yellow indicator is lit.</p> <p>When the system is in this state, the guarded machine is not allowed to operate until the detection zone is clear of obstructions, and the start button is pressed and released.</p>
Weak state	Blue		<p>This state occurs when the signal is weak and thus the blue indicator is lit (only available on type 4 finger detection and long range type 4 for hand and body detection).</p> <p>Two possible root causes leading to a weak signal are:</p> <ul style="list-style-type: none"> <li>• Misalignment between transmitter and receiver.</li> <li>• Dirty optical surface.</li> </ul>

## Cascaded Function (XUSL4E)

### General Description

Special models of the XUSL4E safety light curtains can become the primary in a cascaded system. A cascaded XUSL4E light curtain system allows multiple transmitters and receivers to be daisy-chained, which gives it the flexibility to guard multiple areas of a machine. This cascaded system has single pair of safety outputs and no interference between light curtains mounted in close proximity and in alignment with each other.

Primary segment XUSL4E safety light curtains have a reference suffix M and the Secondary 1 and Secondary 2 segments have a reference ending with S1 and S2.

### Features and Requirements

The XUSL4E cascaded function has the given features and requirements:

- Available in different protective heights.
- The maximum size of the system is based on the number of beams. A single primary segment does not exceed 180 beams, and the total of the combined segments does not exceed 540 beams.
- XUSL4E segments with different resolutions can be mixed.
- A single Secondary segment cannot exceed 180 beams.
- Up to two Secondary segments can be daisy-chained.
- The maximum cable length between each segment is 50 meters.

This figure describes an example of cascaded function:

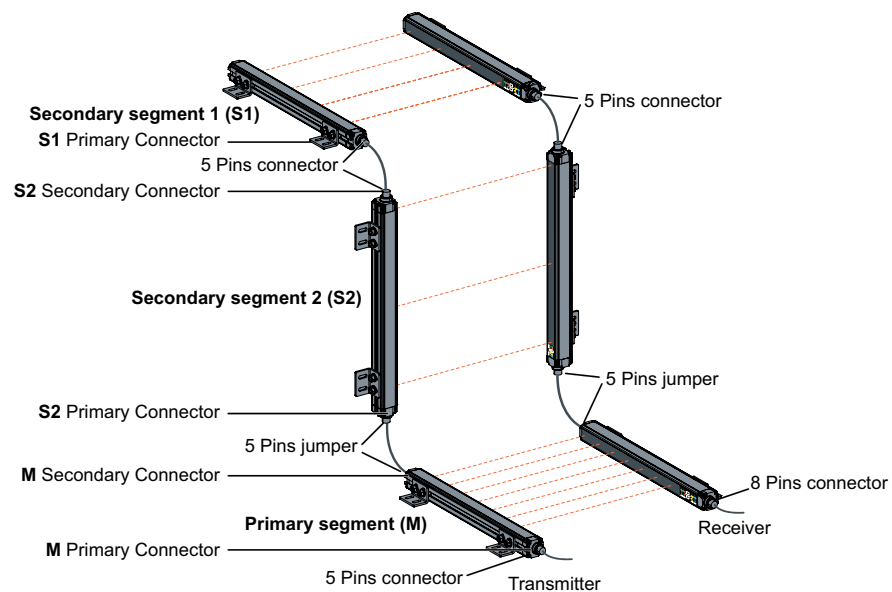

## Muting

### General Description

The Muting function bypasses the protective function of safety-related control systems, such as the XUSL4E/XUSL2E light curtain system, during a predetermined, non-hazardous portion of the machine's operation.

When the XUSL4E/XUSL2E light curtain system is in the Mute state, an indicator lamp must be used. The lamp must be visible to all personnel in the immediate area.

The mute mode is active only when the correct sequence of mute sensor input signals are achieved. The objective of the correct muting sensor selection and orientation is to recognize the presence of the work piece material as the intended means to start or stop the muting sequence. Any entry into the detection zone by any animate or inanimate object results in a stop signal being sent to the guarded machine.

The XUSL4E/XUSL2E safety light curtain can provide muting function by using a XPSLCMUT1160 safety control unit. For more information, refer to the Muting Safety Control Unit XPSLCMUT1160 User Manual.

This figure shows the safety light curtain with associated muting safety control unit:

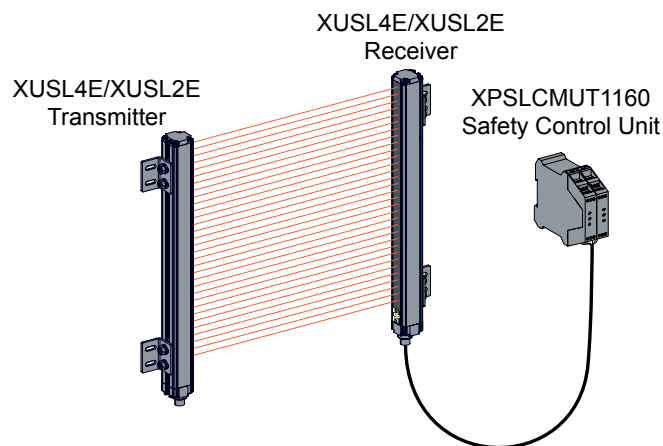

In the given example for conveying application, the muting function is implemented to allow the packages (and the packages only) to enter inside the hazardous area without switching the safety light curtain OFF:

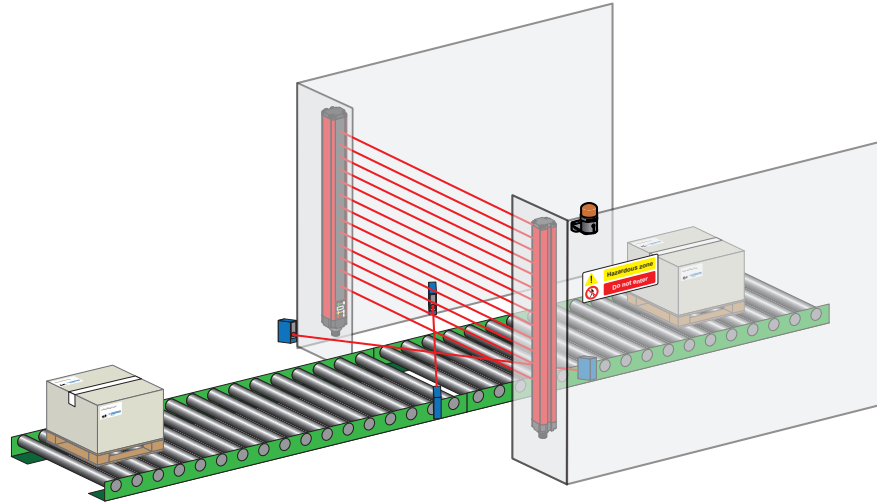

### **⚠ WARNING**

#### **UNINTENDED OUTPUT OPERATION**

The sensor positions and seunce activation determine the muting function.

Verify that muting is funtioning before commissioning the light curtain.

**Failure to follow these instructions can result in death, serious injury, or equipment damage.**

# System Components

## Overview

This section describes the system components and the main features of the safety light curtain.

## System Components Identification

### General Description

This figure displays the system components:

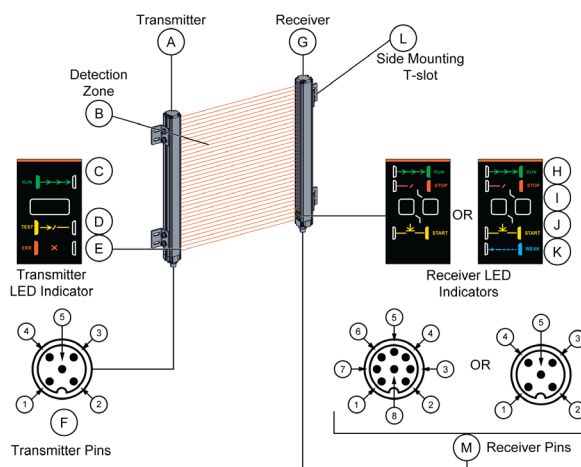

This table describes the system components:

Component	Description	Component	Description			
A	<b>Transmitter</b>	G	<b>Receiver</b>			
B	Detection zone	H	Run state - Green			
C	Run state - Green	I	Error or Stop state - Red			
D	Test state - Orange	J	Start state - Yellow			
E	Error or Power up state - Red	K	Weak state - Blue (XUSL4E14F*** and Type 4 long range models)			
		L	Side mounting T-slot			
<b>F</b>	<b>Transmitter Connections (male)</b>		<b>M</b>	<b>Receiver Connections (male)</b>		
	<b>M12, 5-Pins</b>				<b>M12, 8-Pins*</b>	<b>M12, 5-Pins**</b>
	<b>Pin</b>	<b>Description</b>		<b>Pins</b>	<b>Description</b>	<b>Description</b>
	1	+24 Vdc		1	OSSD1	+24 Vdc
	2	Configuration_0 or Primary/Secondary_A		2	+24 Vdc	Primary/Secondary_A
	3	0 Vdc		3	OSSD2	0 Vdc
	4	Configuration_1 or Primary/Secondary_B		4	Configuration_A	Primary/Secondary_B
5	Functional earth(FE)	5	K1_K2 Feedback/Restart	FE		
		6	Configuration_B	-		
		7	0 Vdc	-		
		8	FE	-		

\* Primary connector of primary segment (XUSL4E) or single pair models (XUSL2E or XUSL4E).\*\* Secondary connector of primary segment or secondary models (XUSL4E).

## **NOTICE**

### **UNINTENDED EQUIPMENT OPERATION**

For more details on IP69K models, refer to [Electrical Connections, page 58](#).

**Failure to follow these instructions can result in equipment damage.**

## XUSL2E/XUSL4E Features

### Features

This table describes the main standard features of XUSL2E and XUSL4E safety light curtains:

Features	XUSL2E		XUSL4E		
	Hand	Body	Finger	Hand	Body
Two PNP safety outputs (OSSD)	X	X	X	X	X
Automatic/manual start/restart selectable	X	X	X	X	X
External Device Monitoring (EDM) feedback input	X	X	X	X	X
LED indicators for status and diagnosis	X	X	X	X	X
Test command	X	X	X	X	X
Adjustable mounting brackets (provided)	X	X	X	X	X
Sensing range selection 0...3 m or 1...6 m selectable	–	–	X	–	–
Sensing range selection 0...4 m or 0...12 m selectable	X	X	–	X	X
Sensing range selection 0...10 m or 3...20 m selectable	–	–	–	X	X
Non-shielded cables (To be ordered separately)	X	X	X	X	X
Muting through XPSLCMUT1160 safety control unit	X	X	X	X	X
Cascadable (daisy-chained) primary/secondary	–	–	X	X	X

X indicates feature availability in the corresponding light curtain model.

# Preinstallation Considerations

## What's in This Part

Safe Mounting Distance .....	36
Additional Mounting Considerations .....	47

## Overview

This part provides detailed information about the safe mounting distance and additional mounting considerations.

# Safe Mounting Distance

## What's in This Chapter

European Safe Mounting Distance Formula .....37  
 Detection Zone Approaches .....39  
 U.S. Safe Distance Formula .....44

## Overview

<b>NOTICE</b>
<b>UNINTENDED EQUIPMENT OPERATION</b>
All quotation and statements from Occupational Safety and Health Administrator (OSHA) and American National Standard Institute (ANSI) apply to the USA only.
<b>Failure to follow these instructions can result in equipment damage.</b>
<b>⚠ WARNING</b>
<b>IMPROPER SETUP</b>
<ul style="list-style-type: none"> <li>• Install the XUSL2E/XUSL4E light curtain system at the safe mounting distance calculated using the appropriate formula.</li> <li>• Ensure that the XUSL2E/XUSL4E light curtain system is mounted far enough away from the operations hazard to fully accommodate the stopping time.</li> <li>• When using a safety control unit like safety relays or controllers the response time of the safety control unit must be added to the overall system stopping time.</li> </ul>
<b>Failure to follow these instructions can result in death, serious injury, or equipment damage.</b>

The XUSL2E/XUSL4E light curtain system must be mounted at safe distance from the hazard zone so that the machine stops before a hand or other body part reaches the hazardous area. This distance is called the minimum safe mounting distance **S**. It is a number calculated from a formula. Before installing the XUSL2E/XUSL4E safety light curtain, you must determine the safe mounting distance.

Regardless of the calculated distance, never mount an XUSL2E/XUSL4E light curtain system closer to a point of operation hazard than specified [Table O-10, page 44](#).

This figure displays the minimum safe mounting distance (**S**) to a point of operation or hazardous area :

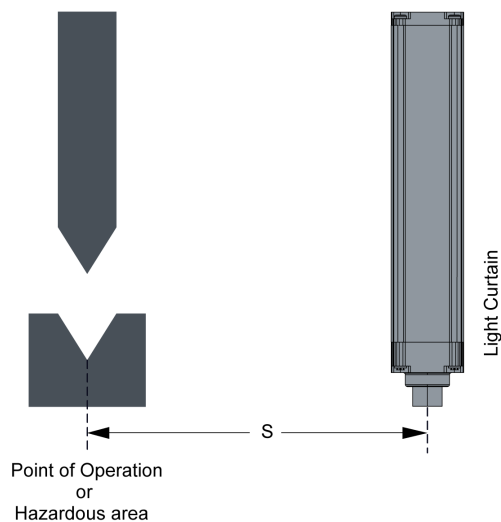

# European Safe Mounting Distance Formula

## Introduction

The minimum safe mounting distance discussed in this section is based on European standard ISO 13855. This standard applies to light curtains used in industrial environments.

## General Formula

The minimum safe mounting distance **S**, is calculated from the following formula:

**S = (K x T) + C, where:**

<b>S</b> = the minimum safe distance in millimeters between the hazard zone and the detection point, line, plane, or zone.	
<b>K</b> = the theoretical speed of approach of the body, or parts of the body, in millimeters per second.	
<b>T</b> = the overall system stopping performance in seconds.	
<b>T = t1 + t2, where:</b>	
<b>t1 =</b>	the maximum response time of the light curtain in seconds. This is the time it takes for the output signal switching devices to change to OFF state after the light curtain actuates. This value is listed on the light curtain labels and in the <a href="#">Specifications, page 76</a> of this manual.
<b>t2 =</b>	the maximum response time of the machine in seconds. This is the time it takes for the machine to stop or remove the risk after it receives the output signal from the light curtain.
<b>C</b> = an additional distance in millimeters based on the resolution of the light curtain.	

## Applying the Formula

The values of variables **K** and **C** used in the general formula vary depending on how the light curtain is mounted.

Three light curtain mounting schemes are discussed in this section. Refer to the method appropriate for your application, and use the applicable safe distance formula:

- Normal (perpendicular) approach: The direction of approach for the operator is perpendicular to the detection zone. For more information, refer to the [Normal approach figure, page 37](#).
- Parallel approach: The direction of approach for the operator is parallel to the detection zone. For more information, refer to the [Parallel approach figure, page 38](#).
- Angled approach: The direction of approach for the operator is at an angle to the detection zone. For more information, refer to the [Angled approach figure, page 39](#).

# Detection Zone Approaches

## Normal (Perpendicular) Approach

This figure displays the normal (perpendicular) approach to the detection zone :

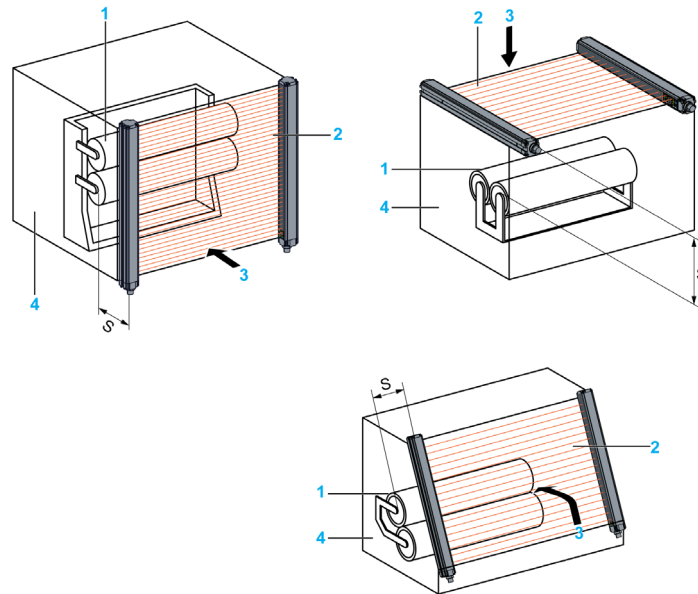

**S:** Minimum safe distance

**1:** Hazardous zone

**2:** Detection zone

**3:** Direction of approach

**4:** Fixed guard

If the operator's direction of approach is perpendicular to the detection zone as shown in the figure and the resolution of the system is 40 mm or less, use the following formula to calculate the safe mounting distance, **S**:

$$S = (K \times T) + C$$

**S = (2000 mm/s x T) + 8 x (R - 14 mm), where:**

<b>K</b>	= 2000 mm/s
<b>T</b>	= Total response time
<b>C</b>	= 8 x (R - 14 mm), but not less than 0
<b>R</b>	= Resolution of the light curtain in millimeters.

You can calculate the safe mounting distance **S**, using this formula with values for **T** and **R** that are appropriate for the light curtains.

The following lists the conditions for safe mounting distance calculation:

- If the calculated value of **S** is greater than or equal to 100 mm (3.94 in.) and less than or equal to 500 mm (19.68 in.), use the calculated value for the safe mounting distance.
- If the calculated value of **S** is less than 100 mm, use 100 mm as the safe mounting distance.
- If the calculated value of **S** is greater than 500 mm (19.68 in.), recalculate **S** with an alternate value for **K** as shown in the given formula:

$$S = (1600 \text{ mm/s} \times T) + 8 \times (R - 14 \text{ mm})$$

## Parallel Approach

This figure displays the parallel approach to the detection zone:

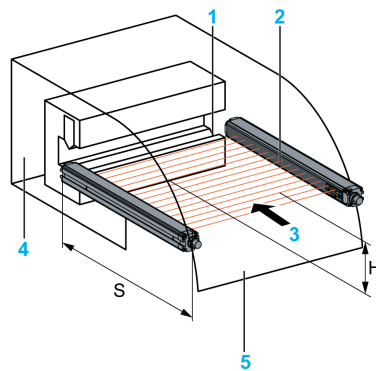

**S:** Minimum safe distance

**1:** Hazardous zone

**2:** Detection zone

**3:** Direction of approach

**4:** Fixed guard

**5:** Beginning of the detection zone

If the operator's direction of approach is parallel to the detection zone as shown in the figure, calculate the minimum safe mounting distance, **S**, with the following formula:

$$S = (1600 \text{ mm/s} \times T) + (1200 \text{ mm} - 0.4 \times H), \text{ where:}$$

<b>K</b>	= 1600 mm/s
<b>C</b>	= 1200 mm – 0.4 x <b>H</b> (not less than 850 mm), where: <b>H</b> = the height of the detection zone above the reference plane (for example, the floor) in millimeters.
<b>NOTICE</b>	
<b>UNINTENDED EQUIPMENT OPERATION</b>	
The maximum value allowed for <b>H</b> is 1000 mm (39.37 in.). If the value of <b>H</b> exceeds 300 mm (11.81 in.), then additional protective devices must be used	
<b>Failure to follow these instructions can result in equipment damage.</b>	

## Angled Approach

This figure displays the angled approach to the detection zone:

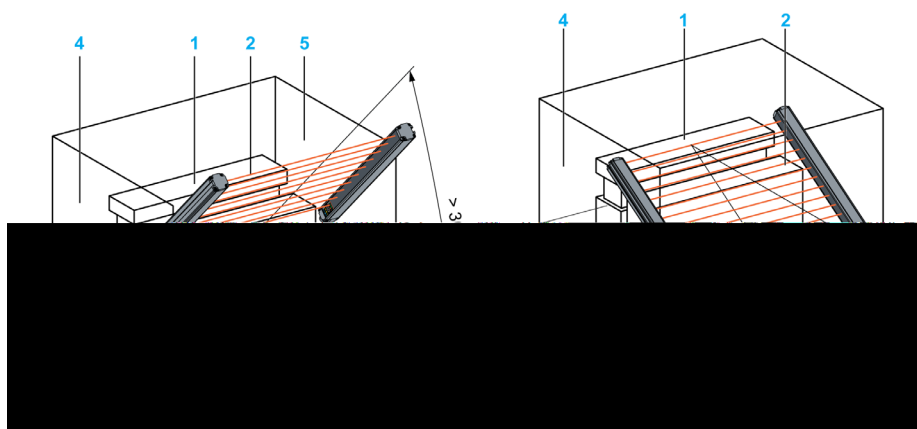

- S:** Minimum safe distance
- 1:** Hazardous zone
- 2:** Detection zone
- 3:** Direction of approach
- 4:** Fixed guard
- 5:** Beginning of the detection zone

When the operator’s direction of approach is at an angle to the detection zone as shown in the figure, the safe mounting distance formula depends on the size of the angle.

The following lists the conditions for safe mounting distance calculation at different angles:

- If the angle is greater than 30°, use the formula provided for the [Normal \(Perpendicular\) Approach, page 37](#).
- If the angle is less than or equal to 30°, use the formula provided for the [Parallel approach figure, page 38](#).

## Calculation Example

### Normal (Perpendicular) Approach

In this example, the machine has a stopping time of 60 ms ( $t_2$ ). It is fitted with a light curtain having a resolution of 30 mm ( $R$ ) and a response time of 30 ms ( $t_1$ ). The light curtain is mounted in such a way that the direction of approach of the operator is perpendicular to the detection zone as shown in the [Normal approach figure, page 37](#).

Use the formula for normal (perpendicular) approach with a resolution of less than 40 mm, to calculate the minimum safe mounting distance, **S**:

The formula is **S = (2000 mm/s x T) + 8 x (R – 14 mm)**, where:

<b>T</b>	= Total response time ( $t_1 + t_2$ ) = (60 + 30) ms = 90 ms, or 0.09 s
<b>R</b>	= 30 mm

Calculate as follows:

$$S = (2000 \text{ mm/s} \times 0.09 \text{ s}) + 8 \times (30 - 14) \text{ mm}$$

$$S = (180 + 128) \text{ mm}$$

$$S = 308 \text{ mm}$$

## Multiple Beam Models

The minimum safe mounting distance is calculated by the formula:

$$S = (1600 \text{ mm/s} \times T) + 850 \text{ mm}$$

where:

<b>T</b>	= Total response time
----------	-----------------------

Perimeter access systems consist of multiple separate beams. These types of devices are designed for body detection and not torso detection.

This table shows the practical positions for a 2, 3, and 4-beam system:

Positions for Multiple Beam Systems	
No. of beams	Height of beams above reference plane (for example, the floor)
4	300, 600, 900, 1200 mm
3	300, 700, 1100 mm
2	400, 900 mm

This figure displays the example of beam positions with 3 beams model:

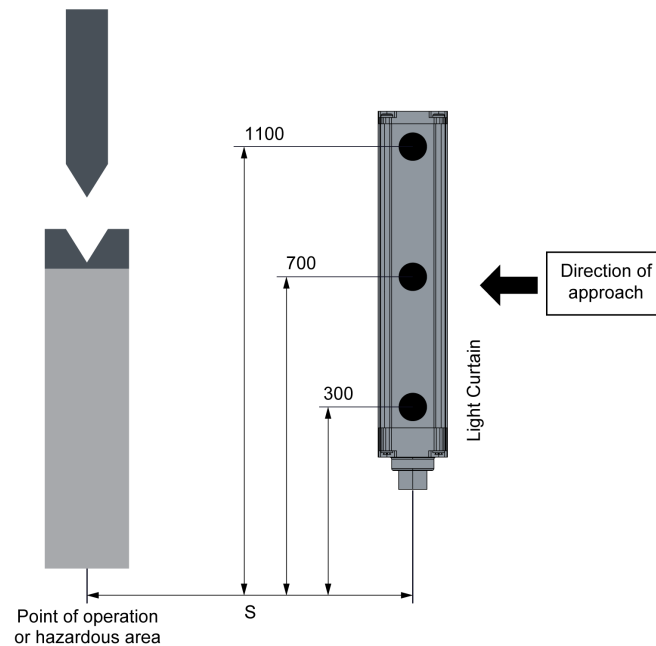

<b>⚠ WARNING</b>
<p><b>IMPROPER SETUP</b></p> <ul style="list-style-type: none"> <li>• Multiple beam models are designed for body detection. Do not use multiple beam models for torso, arm or leg detection</li> <li>• For the lowest beam, 400mm can only be used when the risk assessment allows it.</li> </ul> <p><b>Failure to follow these instructions can result in death, serious injury, or equipment damage.</b></p>

**⚠ WARNING****IMPROPER SETUP**

Consider the following possible scenarios during the risk assessment :

- Crawling below the lowest beam, reaching over the top beam.
- Reaching over the top beam.
- Reaching through two of the beams.
- Bodily access - intrusion between two beams.

**Failure to follow these instructions can result in death, serious injury, or equipment damage.**

## Factors Affecting the Safe Distance Formula

When light curtains are used to initiate the machine, their resolution must be 30 mm or less according to ISO 13855 standard (this requirement may vary with other standards).

In machine initiation applications, use the formula given for normal (perpendicular) approach with a resolution of less than 40 mm to calculate the minimum safe mounting distance (**S**). However, if the calculated value of **S** is less than 150 mm, use 150 mm as the safe mounting distance.

**⚠ WARNING****IMPROPER SETUP**

If the calculated distance **S** is such that an operator can stand between the barrier and the hazard zone, additional protection is required, such as physical guard or barrier comprising several parts. Consult all applicable standards.

**Failure to follow these instructions can result in death, serious injury, or equipment damage.**

## U.S. Safe Distance Formula

### General Description

There are two different formulas available to calculate the safe mounting distance for light curtains that are mounted vertically. They are as follows:

- One formula described in OSHA 1910.217, applies to the guarding of mechanical power presses, but should serve as a guide for other machine applications.
- The American National Standards Institute (ANSI) standard uses another formula which takes into consideration more factors when calculating the safe mounting distance.

The basic formulas for calculating safe mounting distances for light curtains mounted vertically are in this section. These formulas apply to all light curtains.

### U.S. Safe Distance Formula ANSI B11.1

The ANSI B11.1 formula is described here.

**$D_s = K \times (T_s + T_c + T_r + T_{bm}) + D_{pf}$ , where:**

<b>D<sub>s</sub></b>	The minimum safe distance between the light curtain sensing area and the nearest point of potential operation hazard
<b>K</b>	A hand-speed constant of 63 inches per second. This is the minimum value accepted by ANSI standards. ANSI recognizes that this constant may not be optimal, and thus you should consider all factors before deciding on the value of <b>K</b> for use in the formula.
<b>T<sub>s</sub></b>	The stopping time of the machine (i.e., a press), as measured from the final control device. <b>T<sub>s</sub></b> is measured at the maximum velocity.
<b>T<sub>c</sub></b>	The time it takes the control circuit to activate the braking system. <b>NOTE:</b> T <sub>s</sub> and T <sub>c</sub> are measured together by a stop time measurement device.
<b>T<sub>r</sub> = t<sub>1</sub></b>	The response time of the XUSL2E/XUSL4E safety light curtain in milliseconds. For more information, refer to <a href="#">Specifications, page 76</a> .
<b>T<sub>bm</sub></b>	The additional time that the brake monitor allows to compensate for wear and variations in the stopping time (brake monitors stops the machine when the stop time of the machinery exceeds a preset limit). <div style="border: 1px solid black; padding: 5px; margin-top: 10px;"><p style="text-align: center;"><b>NOTICE</b></p><p><b>UNINTENDED EQUIPMENT OPERATION</b></p><p>If brake monitoring is not installed on the machine, a factor must be added to the measured stop time to include brake wear. Approximately, the brake monitoring allows 20% to 25% additional stop time. To determine the actual value, contact the machine manufacturer.</p><p><b>Failure to follow these instructions can result in equipment damage.</b></p></div>
<b>D<sub>pf</sub></b>	(Depth penetration factor) The maximum travel toward the hazard within the detection zone that may occur before a stop is signaled. Depth penetration factors vary depending on the light curtain model and the application as given below: <ul style="list-style-type: none"> <li>• D<sub>pf</sub> is 0.9 m (36 in.) for an application that allows only a person's arm to reach through the detection zone (typically a model with three or more beams).</li> <li>• D<sub>pf</sub> is 1.2 m (48 in.) for an application that allows a person to bend over the detection zone and reach through it towards the hazard (typically a two-beam model).</li> </ul>

This figure describes the Depth Penetration Factor (Dpf) calculation:

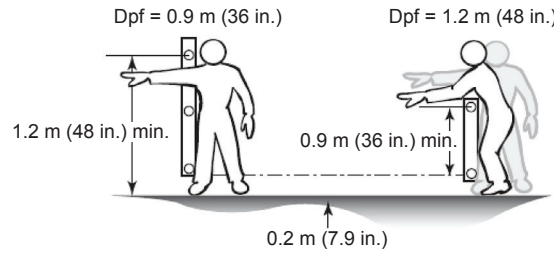

For 14 mm (0.551 inches) and 30 mm (1.181 inches) resolutions, the depth penetration factor is determined using the Depth Penetration Factor Chart from ANSI B11.1 (shown in figure below). Alternately, the following ANSI formula can be used:

**Dpf = 3.4 x (R - 0.276),** where

**R** = Resolution in inches

**Depth Penetration Factor Vs Resolution**

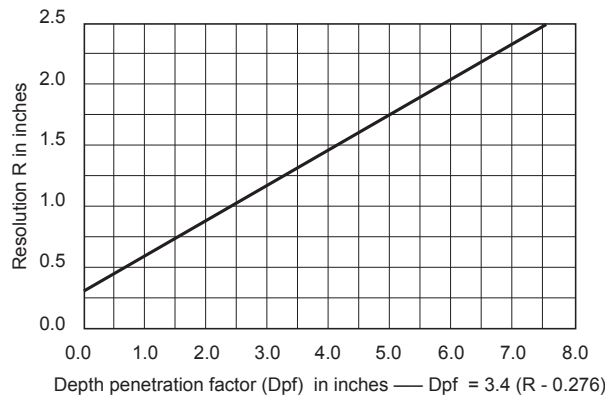

**U.S. Safe Distance Formula (OSHA CFR 1910.217)**

The OSHA formula is described here.

**Ds = 63 in. per second x Ts,** where:

<b>Ds</b>	Minimum safe mounting distance (inches). 63 in. per second = hand speed constant
<b>Ts</b>	Stop time of the machine (i.e. a press), as measured from the final control element. It is measured to determine worst case time and maximum velocity of the press, usually at 90° of press rotation on the downstroke.

In addition to the formula above, we recommend you to follow OSHA 1910.217 Table O-10 also. This table shows the maximum width of openings allowed for a guard based on the distance from the light curtain to the point of operation hazard. The maximum width of the opening shown in this table corresponds to the resolution of the light curtain.

**OSHA 1910.217 Table O-10**

<b>Distance from the Light Curtain to the Point of Operation Hazard (inches)</b>	<b>Maximum Width of Opening - Resolution (inches)</b>
0.5...1.5	0.25
1.5...2.5	0.375
2.5...3.5	0.5
3.5...5.5	0.625
5.5...6.5	0.75
6.5...7.5	0.875
7.5...12.5	1.25
12.5...15.5	1.5
15.5...17.5	1.875
17.5...31.5	2.125

### ***NOTICE***

#### **UNINTENDED EQUIPMENT OPERATION**

If the guarded machine is not equipped with downtime monitoring, a percentage increase factor should be applied to the stop time of the machine to allow for braking system wear. Contact your machine manufacturer for information.

**Failure to follow these instructions can result in equipment damage.**

# Additional Mounting Considerations

## What’s in This Chapter

Reflective Surface Interference ..... 47

Test Rod Procedure ..... 51

Additional Guarding ..... 52

Multiple Systems..... 53

## Overview

This chapter describes additional mounting considerations.

<b>DANGER</b>
<b>HAZARD OF ELECTRIC SHOCK, EXPLOSION, OR ARC FLASH</b>
Never remove the end caps of the safety light curtain system.
<b>Failure to follow these instructions will result in death or serious injury.</b>

<b>⚠ WARNING</b>
<b>IMPROPER SETUP</b>
<ul style="list-style-type: none"> <li>• Read the information in this section completely before starting the <a href="#">installation procedures, page 53</a></li> <li>• An XUSL2E/XUSL4E light curtain system must be installed, checked, and maintained by a qualified personnel as defined in the <a href="#">Meeting Full Compliance, page 8</a>.</li> <li>• The user must be familiar with the installation requirements, safe mounting distance, system controls, and features before using the XUSL2E/XUSL4E light curtain system.</li> </ul>
<b>Failure to follow these instructions can result in death, serious injury, or equipment damage.</b>

## Reflective Surface Interference

### General Description

A reflective surface such as a machine part, mechanical guard, or workpiece near the detection zone can deflect the optical beam and prevent an obstruction in the protected zone from being detected.

## Example of Reflective Surface Interference

In this figure, the obstruction is not detected due to the reflection. The reflective object or surface is inside the beam angle:

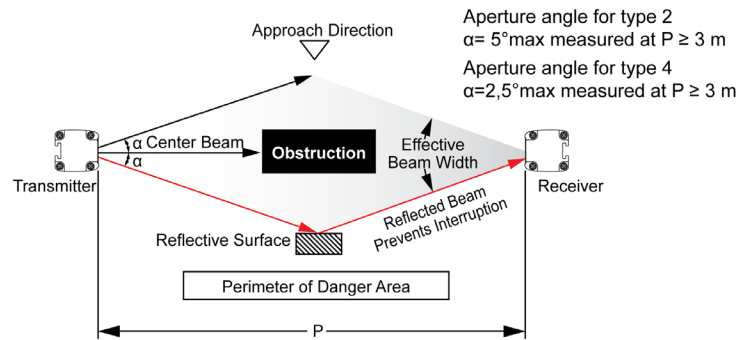

<b>⚠ WARNING</b>
<b>UNINTENDED EQUIPMENT OPERATION</b>
Presence of a reflective surface can lead to an undetected protected zone interruption. Read the information in this section completely before starting the installation procedures.
<b>Failure to follow these instructions can result in death, serious injury, or equipment damage.</b>

## Minimum Distance Between Reflective Surface and Detection Zone

To prevent reflective surface interference, maintain a minimum distance (**D**) between the reflective object and the center line of the XUSL2E/XUSL4E detection zone as shown in the example below.

In this figure, if the reflective object is placed at a distance greater than **D**, the obstruction will be clearly detected:

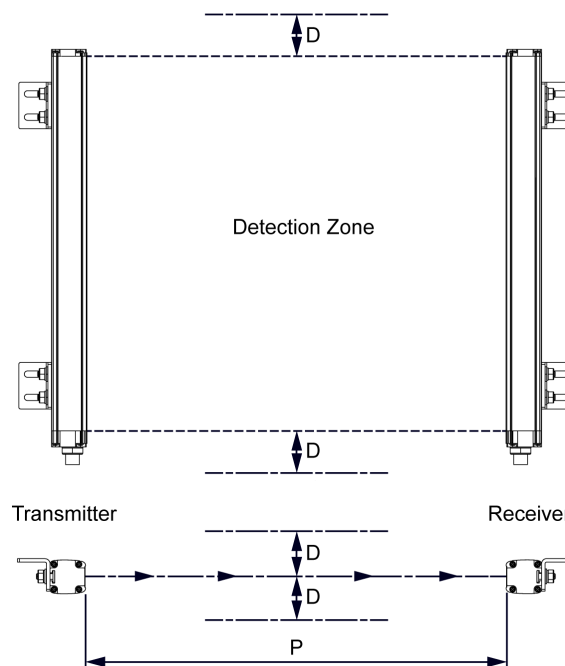

## Minimum Distance (D) from a Reflective Surface as a Function of Operating Range

The minimum distance that must be maintained between the reflective object and the center line of the detection zone as a function of the light curtain's operating range is displayed in this figure:

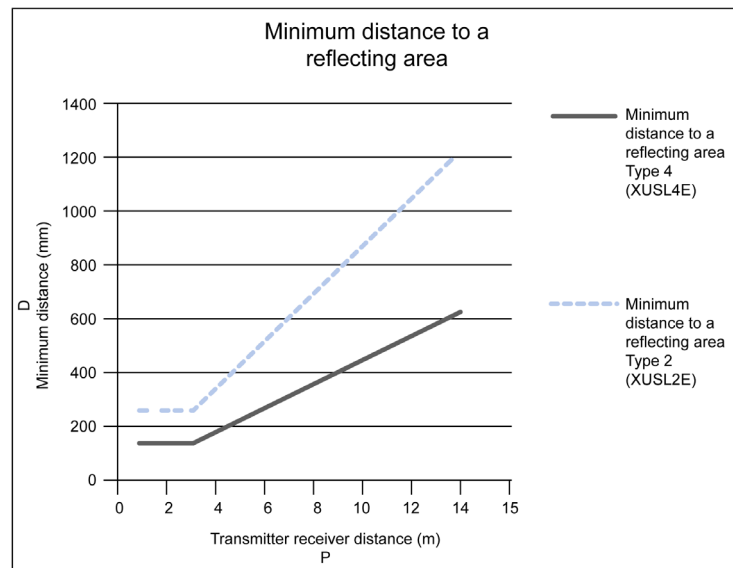

Use the [Test Rod Procedure, page 48](#) to detect any reflective surface interference.

This table describes the type 2 and type 4 minimum distance to a reflecting area for different transmitter receiver distance:

Transmitter Receiver Distance P (m)	Minimum Distance to a Reflecting Area Type 4 (XUSL4E) D (mm)	Minimum Distance to a Reflecting Area Type 2 (XUSL2E) D (mm)
1	131	262
2	131	262
3	131	262
4	175	350
6	262	525
8	349	700
10	437	875
12	524	1050
14	611	1225

To calculate the minimum distance to a reflecting area for type 2 and type 4, use the following conditions:

**Type 4 (XUSL4E)**

If  $P \leq 3$  m, then  $D = 131$  mm

If  $P > 3$  m, then  $D$  (mm) =  $\tan(2.5^\circ) \times 1000 \times P$  [m] =  $43.66 \times P$  [m]

**Type 2 (XUSL2E)**

If  $P \leq 3$  m, then  $D = 262$  mm

If  $P > 3$  m, then  $D$  (mm) =  $\tan(5^\circ) \times 1000 \times P$  [m] =  $87.49 \times P$  [m]

<b>P</b>	transmitter receiver distance (mm)
<b>D</b>	minimum distance to a reflecting area (mm)

It is recommended to use a test rod, to control that the safety light curtain is not bypassed by reflective surfaces. The test rod diameter must be equal to the resolution.

## Test Rod Procedure

### General Description

The test is to be performed in accordance to the figure below by moving the test rod slowly along the indicated path to interrupt every beam one after the other:

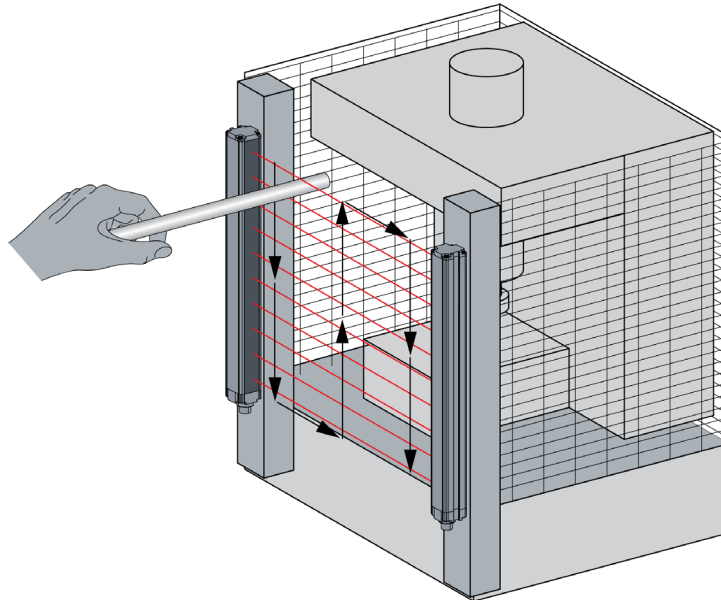

Before starting the test, the green LED must be lit on the receiver. During the test, the Red LED must remain ON (lit) and the Green LED must stay OFF on the receiver. For multiple light beams system, use an opaque object to interrupt the beams one after the other by starting at the center and then close to the transmitter and receiver.

#### **⚠ WARNING**

##### **UNINTENDED EQUIPMENT OPERATION**

- Check the correct operation of the light curtain at power-on phases and before each shift. A proper test object must be used to carry out this test. Suitable test rods for 14 mm and 30 mm resolution are available as [accessories, page 101](#).
- Presence of scratches (even small) can increase the width of the beams emitted by the light curtain leading to a loss of efficiency.
- Particular attention must be paid during the cleaning operation of the window. Do not clean the window of the light curtain with abrasive materials or powders, solvents, alcohol, or corrosive products.

**Failure to follow these instructions can result in death, serious injury, or equipment damage.**

## Additional Guarding

### General Description

Areas of hazard zone that are not guarded by the XUSL2E/XUSL4E light curtain system must be protected by another suitable means. For example, by a fixed barrier guard or an interlocked guard.

### Additional Guarding

This figure displays additional guarding such as a fixed barrier guard and an interlocked guard:

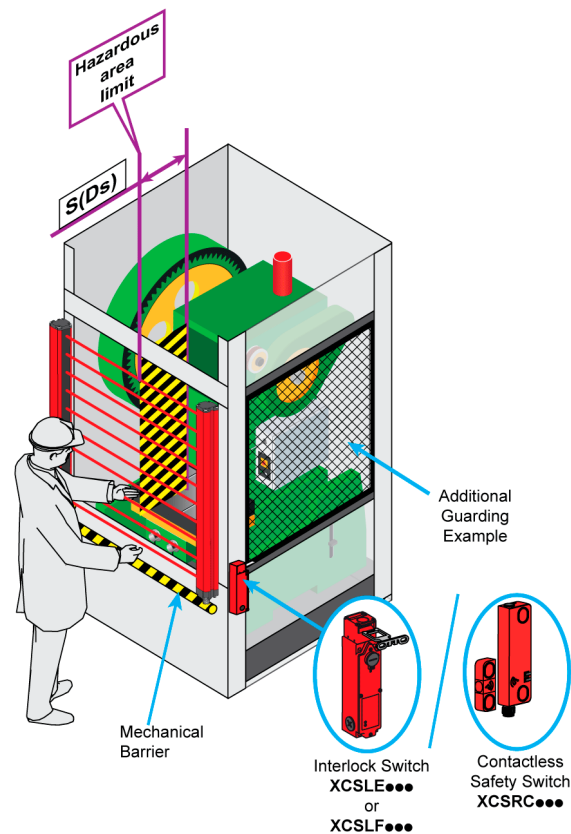

# Multiple Systems

## General Description

When two or more light curtain systems are mounted in close proximity and in alignment with each other, mount the transmitters and receivers back-to-back, or stack them to prevent one light curtain from interfering with another. This precaution is not necessary between the segments of a Primary/Secondary system.

## Multiple Light Curtain Installation Configurations

Configuration	Description	Figure
1	This arrangement is subject to interference between the two light curtains ( <b>Not recommended</b> ).	
2	The receivers are mounted back-to-back ( <b>Recommended</b> ).	

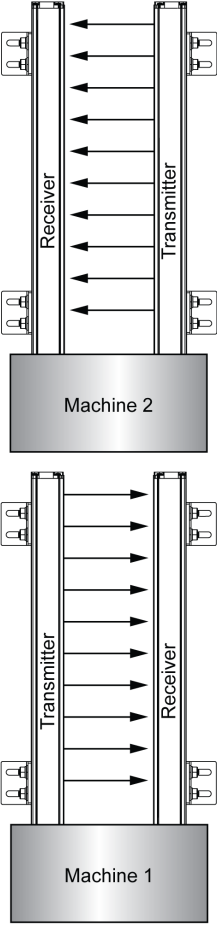
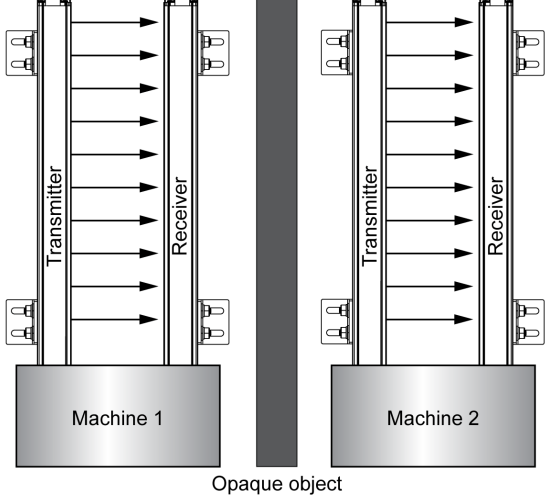
Configuration	Description	Figure
3	The light curtains are stacked, with the transmitters facing in opposite directions ( <b>Recommended</b> ).	
4	The light curtains are separated by an opaque object, which interrupt the beams ( <b>Recommended</b> ).	

**NOTICE**

**UNINTENDED EQUIPMENT OPERATION**

When it is possible, the selection of low range can be an efficient way to limit the interferences due to mounting in close proximity, [page 59](#)

**Failure to follow these instructions can result in equipment damage.**

# Installation, Wiring, and Startup

## What's in This Part

Installation .....	56
Wiring.....	60
Start Up.....	70

## Overview

This section provides information about installation, wiring, and startup.

# Installation

## What's in This Chapter

Parts List.....	56
Mounting the Light Curtain .....	57

## Overview

This chapter describes the installation of the XUSL2E/XUSL4E safety light curtain.

## Parts List

### Parts

This figure displays the different parts of the XUSL2E/XUSL4E light curtain system:

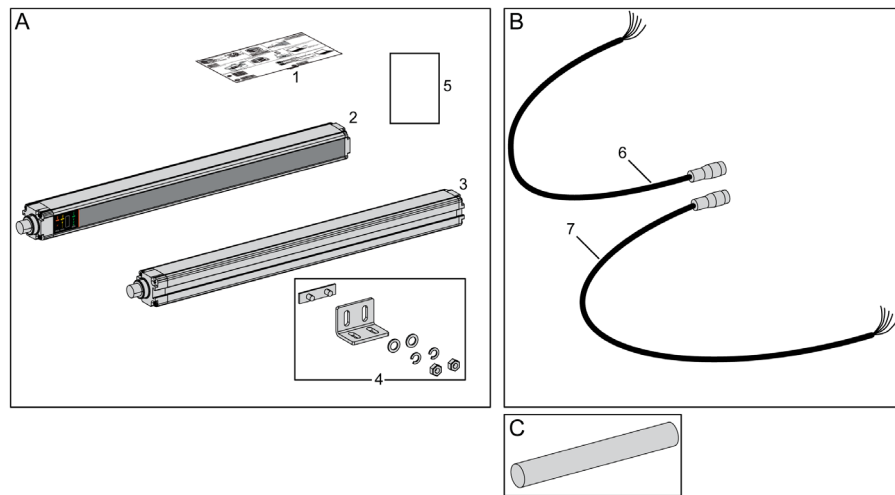

**A.** The XUSL light curtain package includes:

1. Quick start guide.
2. XUSL2E/XUSL4E receiver.
3. XUSL2E/XUSL4E transmitter.
4. Mounting brackets set.
5. EC Declaration of conformity.

**B.** Connection cables (To be ordered separately):

6. Receiver connection cable.
7. Transmitter connection cable.

**C.** Test rod (To be ordered separately).

# Mounting the Light Curtain

## Mounting

### NOTICE

#### UNINTENDED EQUIPMENT OPERATION

Before mounting the light curtain, refer to [Safe Mounting Distance, page 33](#)

**Failure to follow these instructions can result in equipment damage.**

This figure describes the mounting of the light curtain:

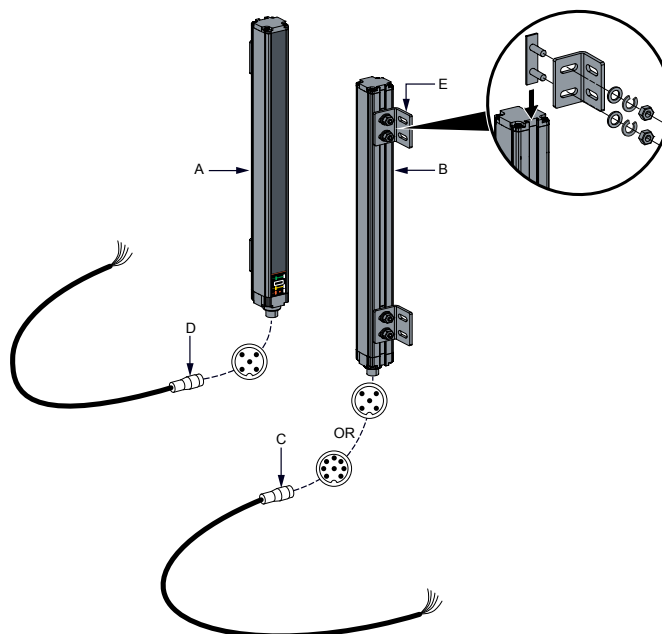

Follow the given procedure to mount the light curtain:

- If the light curtain is installed in an area subject to strong vibrations, vibration damping supports must be used so as not to impair operation of the circuits. To select a kit that is appropriate for your application, refer to [Accessories, page 91](#).
- Using the mounting hardware (E) provided, install the mounting brackets (E) on the groove located in the back of the receiver (B) and transmitter (A). Other special brackets are also available as accessories, refer to [Accessories, page 87](#).
- Connect the cables to the receiver and the transmitter. The receiver cable end (C) has a 8-pin or 5-pin (For more information, refer to [Wiring, page 58](#)) connector and the transmitter cable end (D) has a 5-pin connector.
- Observing the safe mounting distance, mount the receiver and the transmitter on the machine in the same plane and at equal height. For information about alignment and mounting considerations, refer to [Aligning the Transmitter and Receiver, page 70](#).
- Wire the safety light curtain as illustrated in [Wiring, page 58](#).

## NOTICE

### UNINTENDED EQUIPMENT OPERATION

- In case of applications with strong shocks or vibrations, suitable dampers must be used.
- Special brackets allowing a positioning with more mounting flexibility are also available as accessories (Swivel and curved brackets).

**Failure to follow these instructions can result in equipment damage.**

For more information about the given accessories, refer to [Accessories, page 87](#).

## IP69K Models

The IP69K models are suitable when safety light curtains can be exposed to steam or water. The materials used are appropriate for Food and Beverage applications.

The models consist of a pair of safety light curtains pre-mounted inside a specific enclosure (with or without heating system). This enclosure also protects the safety light curtain device against chemicals and can be used in cold areas down to  $-20^{\circ}\text{C}$  ( $-4^{\circ}\text{F}$ ) or  $-30^{\circ}\text{C}$  ( $-22^{\circ}\text{F}$ ). For more details, refer to [Environmental Specifications, page 77](#).

This figure displays the IP69K models with integrated output cables:

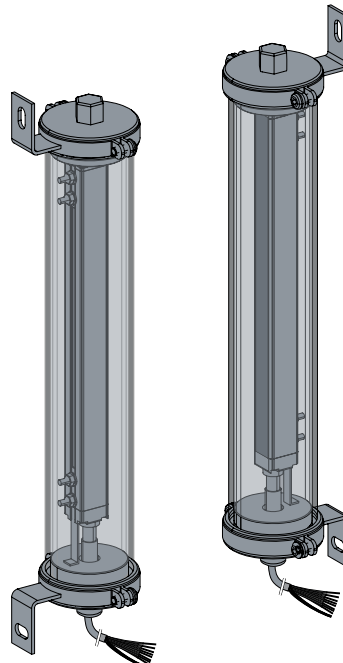

The given table provides the environmental specifications of the IP69K models:

Environmental Characteristics		Description
Ambient air temperature	For operation	-30...+55 °C (-22... 131 °F) with heating system Type 4: -20...+55°C (-4... 131 °F) without heating system Type 2: -30...+55°C (-22... 131 °F) without heating system
	For storage	-30...+70 °C (-22...+158 °F)
Degree of protection	–	IP69K

Environmental Characteristics		Description
Materials	–	End caps: Stainless steel (AISI 316L)/Silicone O-Ring Tube: PMMA (Polymethylmethacrylate) $\varnothing$ 50 mm (1.97 inches) Anti-condensation system (integrated GORE™ valve) Cables: PVC

The given table provides the electrical characteristics of the IP69K models:

Electrical Characteristics	Unit	Description
Power supply	V	24 Vdc $\pm$ 20% 2 A The power supply must meet requirements of IEC 61496-1 and IEC 60204-1.
Maximum current consumption (no load)	mA	Transmitter: 42 mA Receiver: 83 mA
Input power supply	mA	Transmitter: 42 mA Receiver: 900 mA (Including OSSD current)
Safety outputs (OSSD)	–	Two PNP - 400 mA per output @ 24 Vdc, drop out voltage <0.5 Vdc (Integrated arc suppressors)
Signals	–	Transmitter: 1 three-color LED - Red/Amber/Green (power) Receiver: 2 LEDs - 2 two-colors - Red/Green and Yellow/Blue
Connections	–	Pre-wired PVC cable, refer to <a href="#">Electrical Connections, page 58</a> .
Heating system power consumption	W	Maximum 10 W (24 Vdc or 24 Vac)
Cable length	m	10 m
Cable gauge	mm <sup>2</sup>	0.25 mm <sup>2</sup> (AWG24)

This figure describes the mounting of the IP69K models:

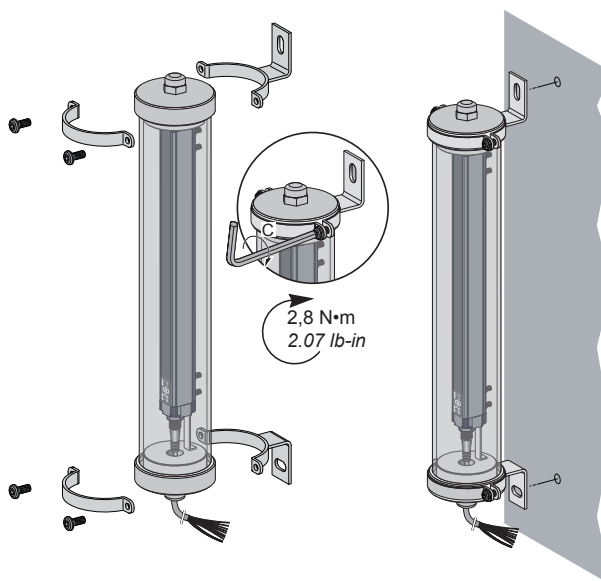

# Wiring

## What's in This Chapter

Electrical Connections .....	61
Connection Schematics .....	64

## Overview

### **⚠ WARNING**

#### **IMPROPER CONNECTION**

- The XUSL2E/XUSL4E light curtain system must be powered by a dedicated voltage (SELV) or a protected extra low voltage (PELV)
- The transmitter and the receiver must be powered with a voltage of 24 Vdc  $\pm$  20%.
- The external power supply must comply with EN 60204-1

**Failure to follow these instructions can result in death, serious injury, or equipment damage.**

The XUSL2E/XUSL4E light curtain system operates directly from a 24 Vdc  $\pm$ 20% power supply. The power supply must meet the requirements of IEC 60204-1 and IEC 61496-1. The SELV part number ABL8RPS24••• is recommended. For more information, refer to [Power Supply, page 88](#).

### **⚠ WARNING**

#### **IMPROPER CONNECTION**

- The XUSL2E/XUSL4E safety light curtains must be connected using both safety outputs.
- The OSSD1 and OSSD2 output signals must not be connected between each other.
- A single safety output, if it fails, may not stop the machine.
- The Receiver provides a voltage of 24 Vdc on BOTH safety outputs. Therefore, the two loads must be individually connected between the corresponding safety output terminal and the 0 Vdc: OSSD1  $\rightarrow$  LOAD1  $\rightarrow$  0 Vdc and OSSD2  $\rightarrow$  LOAD2  $\rightarrow$  0 Vdc.
- When connecting high inductive loads to OSSDs, use suitable voltage suppressors on the outputs.
- The 0 Vdc must be common to all system components.

**Failure to follow these instructions can result in death, serious injury, or equipment damage.**

## Electrical Connections

### Transmitter Connections

This figure describes the transmitter connections:

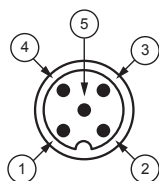

This table describes the pin-wire connections for the M12, 5-Pin transmitter connections:

M12, 5-Pin (XUSL2E and XUSL4E)	
Pin Number	Description
1	+24 Vdc
2	Configuration_0 or Primary/Secondary_A
3	0 Vdc
4	Configuration_1 or Primary/Secondary_B
5	FE
For IP69K electrical connections, refer to IP69K Transmitter connections table given below.	

#### IP69K Transmitter Connections

This table describes the 5 or 8 pre-wired connections for the transmitter:

Wire Color	Description
Brown	+24 Vdc
White	Configuration_0
Blue	0 Vdc
Green or Black	Configuration_1
Grey	FE
Yellow	0 V (Heating system)(1)
Red	+24 Vac/Vdc (Heating system)(1)
Pink	Not connected
(1) Only for XUSL - IP69K models with heating system.	

#### Transmitter Configurations and Operating Modes

This table describes the transmitter configurations and operating modes:

Pin 4 and 2 Range and Test selection	High range option	Low range option	Transmitter in Test state	Forbidden wiring
Pin 4	24 V	0 V	0 V	24 V
Pin 2	0 V	24 V	0 V	24 V

## Receiver Connections

This figure describes the receiver connections:

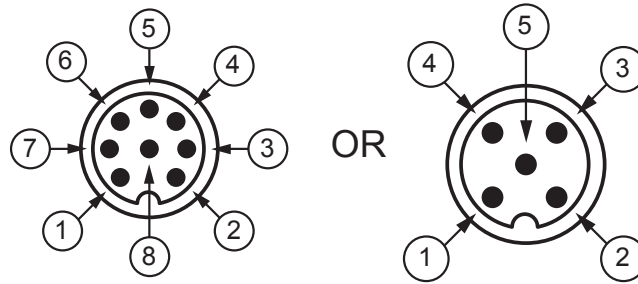

This table describes the pin-wire connections for the M12, 8-Pin, primary connector of primary segment, or single pair models:

<b>M12, 8-PIN Single pair models (XUSL4E or XUSL2E) or Primary connector of primary segment models (XUSL4E)</b>	
<b>Pin Number</b>	<b>Description</b>
1	OSSD1
2	+24 Vdc
3	OSSD2
4	Configuration_A
5	K1_K2 Feedback/Restart
6	Configuration_B
7	0 Vdc
8	FE
* For IP69K electrical connections, refer to IP69K Receiver connections table given below.	

This table describes the pin-wire connections for the M12, 5-Pin secondary connector of primary segment, or secondary segment models:

<b>M12, 5-PIN Secondary connector of primary segment models or Secondary segment models (XUSL4E)</b>	
<b>Pin Number</b>	<b>Description</b>
1	+24 Vdc
2	Primary/Secondary_A
3	0 Vdc
4	Primary/Secondary_B
5	FE

### IP69K Receiver Connections

This table describes the 8 or 10 pre-wired connections for the receiver:

<b>Wire color</b>	<b>Description</b>
White	OSSD1
Brown	+24 Vdc
Green	OSSD2
Yellow	Configuration_A
Grey	K1_K2 Feedback/Restart
Pink	Configuration_B
Blue	0 Vdc
Red	FE
Black	0 V (Heating system) <sup>(1)</sup>
Violet	24 Vac/Vdc (Heating system) <sup>(1)</sup>
(1) Only for XUSL - IP69K models with heating system.	

### Receiver Configurations and Operating Modes

This table describes the automatic integrated control functions:

Configuration	Integrated Control Functions	
	Automatic start/restart without EDM feedback loop	Automatic start/restart with EDM feedback loop
Pin4: Configuration_A	24 Vdc	24 Vdc
Pin5: K1_K2 Feedback/Restart	24 Vdc	24 Vdc through K1_K2 NC feedback contacts in series.
Pin6: Configuration_B	0 Vdc	0 Vdc
Figures		

This table describes the manual integrated control functions:

Configuration	Integrated Control Functions	
	Manual start/restart without EDM feedback loop	Manual start/restart with EDM feedback loop
Pin4: Configuration_A	0 Vdc	0 Vdc
Pin5: K1_K2 Feedback/Restart	24 Vdc through Restart button.	24 Vdc through Restart button and K1_K2 NC feedback contacts in series.
Pin6: Configuration_B	24 Vdc	24 Vdc
Figures		

# Connection Schematics

## Standalone Application

The XUSL2E and XUSL4E light curtains are designed to be used as standalone product when associated with contactors having mechanically linked contacts (force-guided) connected to the OSSDs (that is, without any safety relay, controller, or PLC).

This figure describes the example of wiring diagram for type 4 standalone mode with manual start, contactor contacts feedback loop (EDM) and low range:

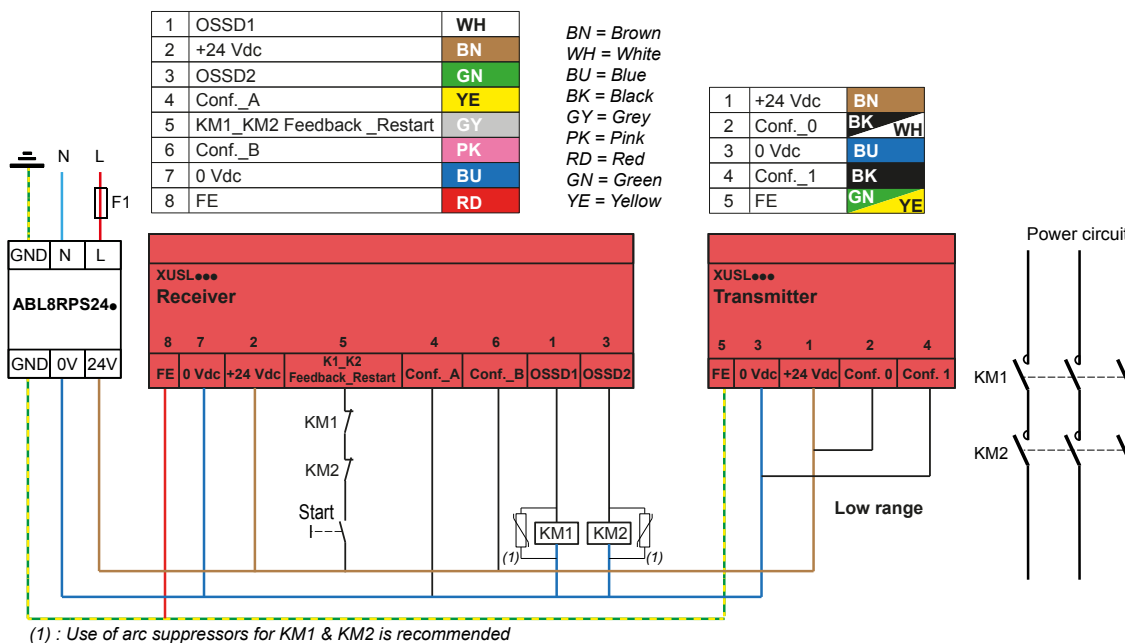

When used in standalone mode, the XUSL2E and XUSL4E are compliant with the following standards respectively:

- Type 2 (IEC 61496-1), SIL1 (IEC 61508) - SILCL1 (IEC 62061), and PLc- Cat.2 (IEC 13849-1).
- Type 4 (IEC 61496-1), SIL3 (IEC 61508) SILCL3 (IEC 62061), and PLe- Cat.4 (IEC 13849-1).

It is the aim of the risk analysis to determine whether the use of type 2 or type 4 standalone safety light curtains are compatible with the expected safety level of the entire system.

<b>⚠ WARNING</b>
<b>UNINTENDED EQUIPMENT OPERATION</b>
The KM1 and KM2 contactors must have <a href="#">force-guided contacts</a> , page 22.
<b>Failure to follow these instructions can result in death, serious injury, or equipment damage.</b>

<b>⚠ WARNING</b>
<b>IMPROPER TYPE UTILIZATION</b>
<ul style="list-style-type: none"> <li>• It is the responsibility of the user or integrator to check whether the use of type 2 or type 4 Safety Light Curtain system is consistent with the application risk assessment.</li> <li>• Perform a risk assessment to choose the right product for your application.</li> </ul>
<b>Failure to follow these instructions can result in death, serious injury, or equipment damage.</b>

## When do we use safety relays, controllers or safety PLCs?

The level of a complete safety system can decrease as the number of safety sensors or functions used increases. The use of safety control units like safety controllers or safety PLC can be helpful for keeping the overall system at the right safety level. Safety control unit can also be justified when additional features are required by the application. The choice between the different ranges of safety control units depends on the number of safety functions and the number of safety sensors used in the application.

This graph is a simplified representation of the common uses of safety control units:

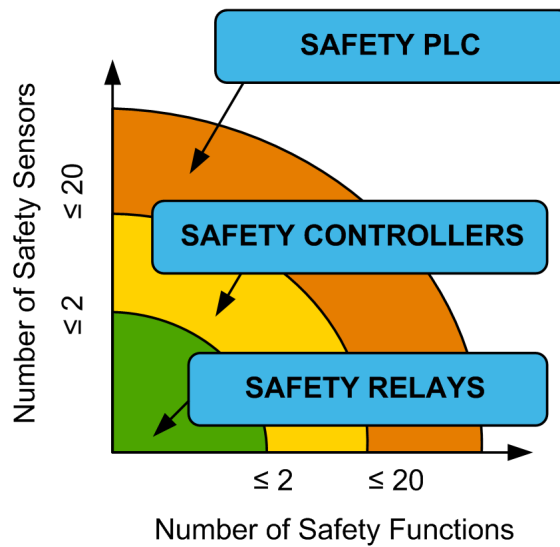

The limit numbers indicated in the graph above are not restrictive and they can vary depending on the applications.

### NOTICE

#### IMPROPER SETUP

When associated with a safety control unit, the safety light curtain must be configured in Automatic start and without EDM. For information about the safety functions performed by the safety control units (monitored start & EDM), please refer to the corresponding instruction sheets.

**Failure to follow these instructions can result in equipment damage.**

## Connecting to a Safety Monitoring Device

The wiring from the XUSL2E/XUSL4E light curtain system to the machine control circuit must be control reliable. The solid-state outputs should be connected only to a control reliable, safety-rated PLC or to a control reliable safety-rated machine system.

## Connecting with an XPSUAK Module

This figure describes the connection of XUSL2E/XUSL4E light curtain system with an XPSUAK module:

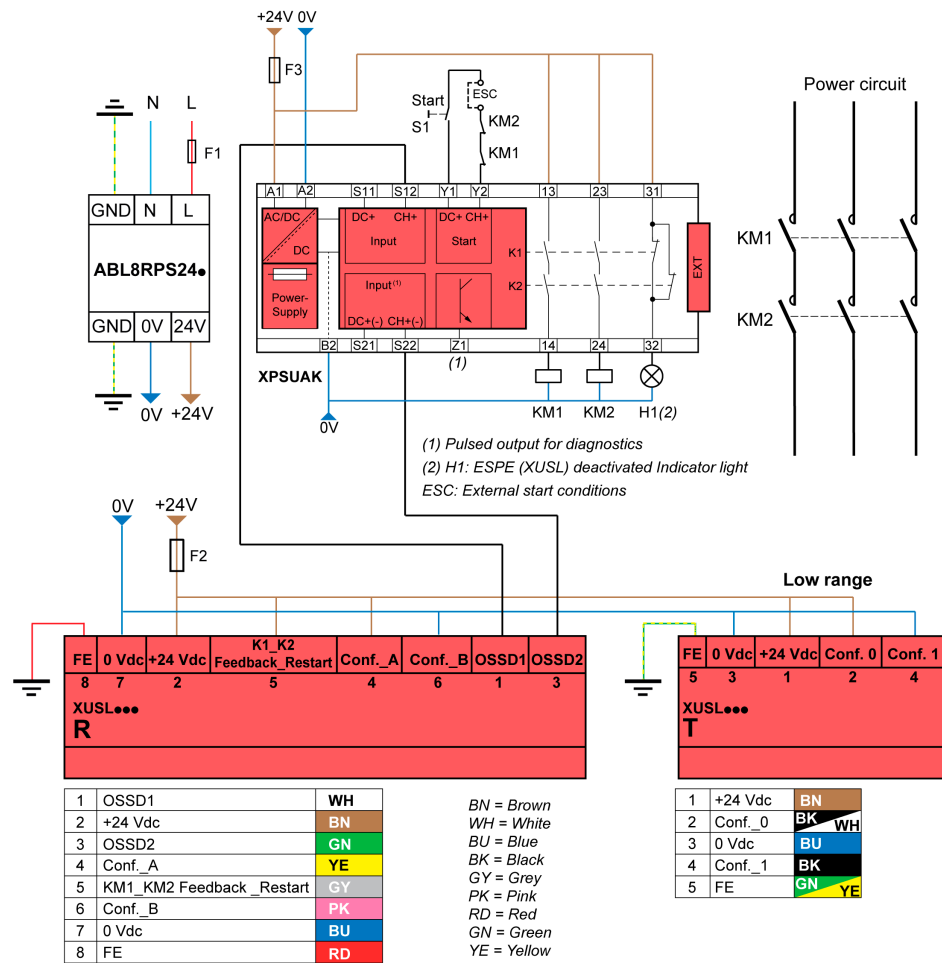

Automatic start is possible by removing the start button in the schematic above (short circuit instead) and by connecting directly S13 to S14. For any start mode, the receiver must be configured by wiring in automatic start and without EDM.

**⚠ WARNING**

**UNINTENDED EQUIPMENT OPERATION**

The KM1 and KM2 contactors must have [force-guided contacts](#), page 22.

**Failure to follow these instructions can result in death, serious injury, or equipment damage.**

## Connecting with an XPSUAF Module

This figure describes the connection of XUSL2E/XUSL4E light curtain system with an XPSUAF module in low range configuration:

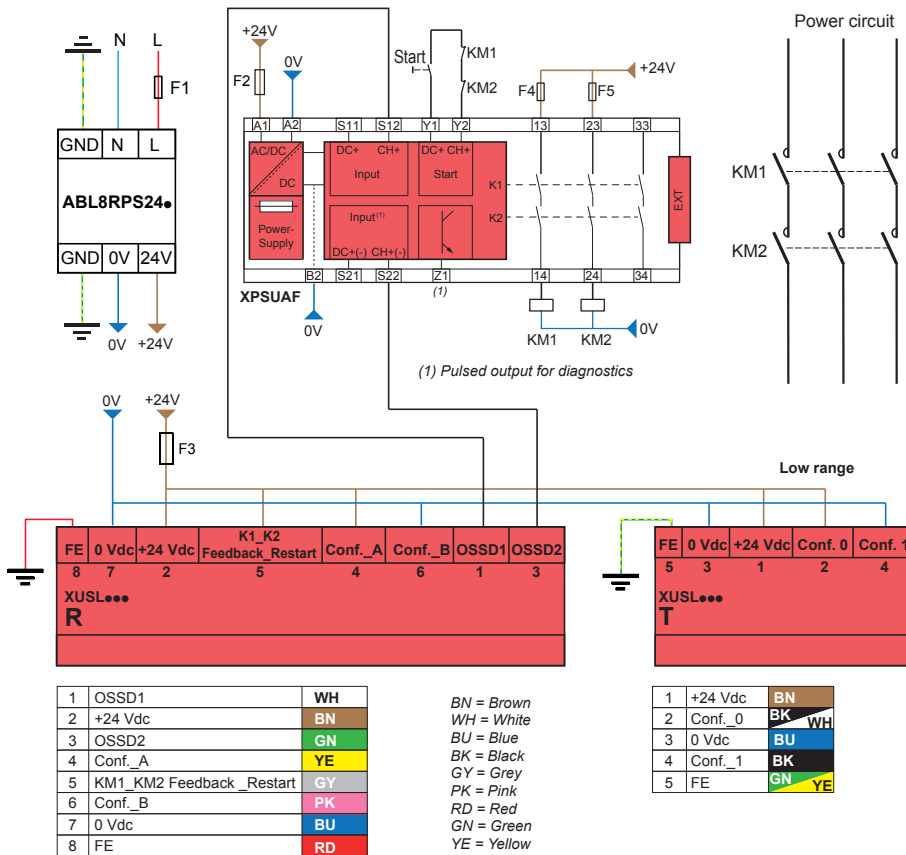

For using the XUSLAF in manual start, the receiver must be configured by wiring in automatic start and without EDM.

### ⚠ WARNING

#### UNINTENDED EQUIPMENT OPERATION

The KM1 and KM2 contactors must have [force-guided contacts](#), page 22.

**Failure to follow these instructions can result in death, serious injury, or equipment damage.**

## Connecting with an XPSMCMER Relay Module

This figure describes the connection of XUSL2E/XUSL4E light curtain system in manual start with EDM with an XPSMCMER0002 safety relay output extension module:

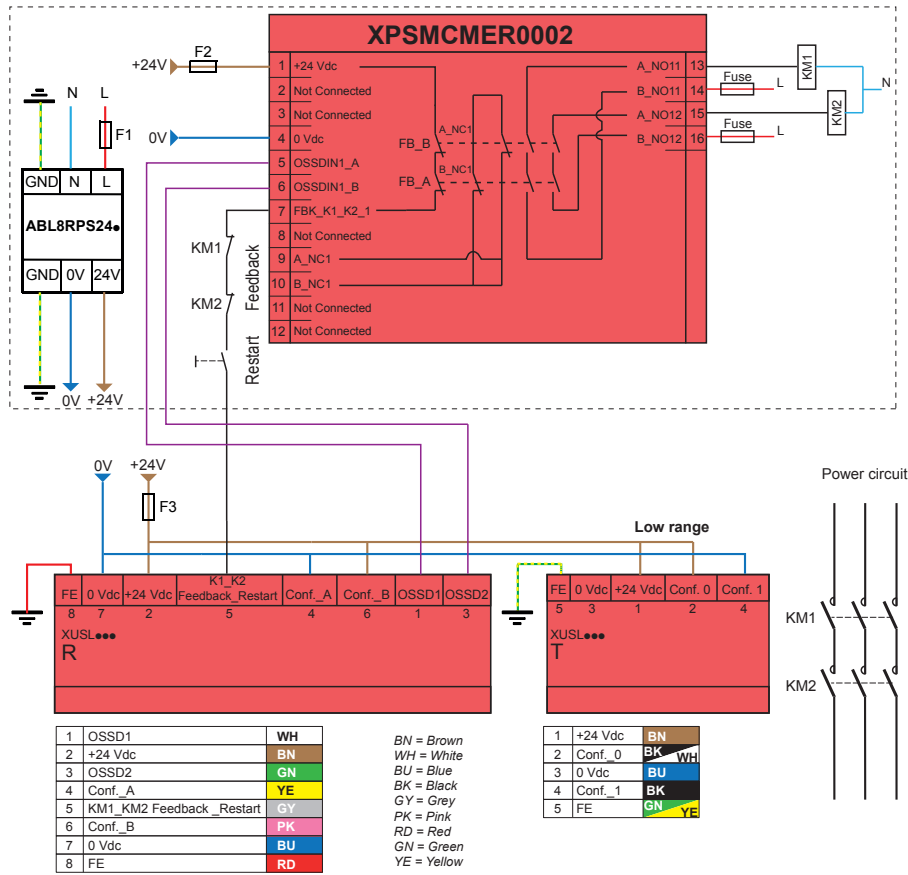

The XPSMCMER safety relay output extension modules do not require a CPU unit XPSMCMCP as they are connected directly to the safety light curtains OSSDs.

For the association with XPSMCMER, the operating modes (manual or automatic start) and EDM must be configured by wiring on the receiver. For example, in the schematic above, automatic start is possible by removing the start button (short circuit instead) and by configuring the receiver in automatic start, with EDM.

**⚠ WARNING**

**UNINTENDED EQUIPMENT OPERATION**

The KM1 and KM2 contactors must have [force-guided contacts](#), page 22.

**Failure to follow these instructions can result in death, serious injury, or equipment damage.**

## Connecting with an XPSMCM Controller

This figure describes the connection of XUSL2E/XUSL4E light curtain system with an XPSMCM controller:

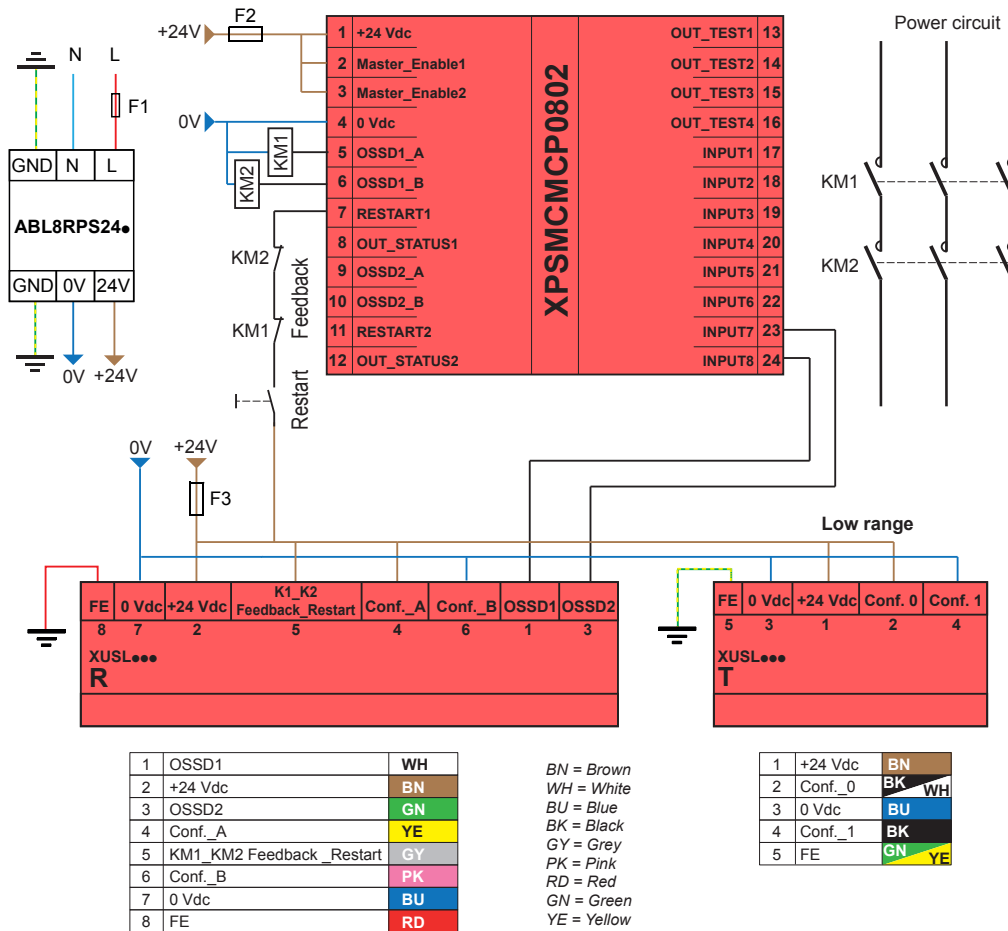

For any start mode, the receiver must be configured by wiring in automatic start and without EDM.

**⚠ WARNING**

**UNINTENDED EQUIPMENT OPERATION**

The KM1 and KM2 contactors must have [force-guided contacts](#), page 22.

**Failure to follow these instructions can result in death, serious injury, or equipment damage.**

# Start Up

## What's in This Chapter

User Interface ..... 70  
 Aligning the Transmitter and Receiver..... 72

## Overview

Follow the given procedure before starting the XUSL2E/XUSL4E safety light curtain:

- Verify that the wiring, power supply voltage, and polarity of connections are correct.
- Apply power to the system.
- Check the LEDs as described in user interface.
- Adjust the alignment of the transmitter and the receiver. For more information, refer to [Aligning the Transmitter and Receiver, page 70](#) and [Troubleshooting, page 71](#).

## User Interface

### LED Meaning and Output States

These figures describes the LED meanings and output states for the safety light curtain:

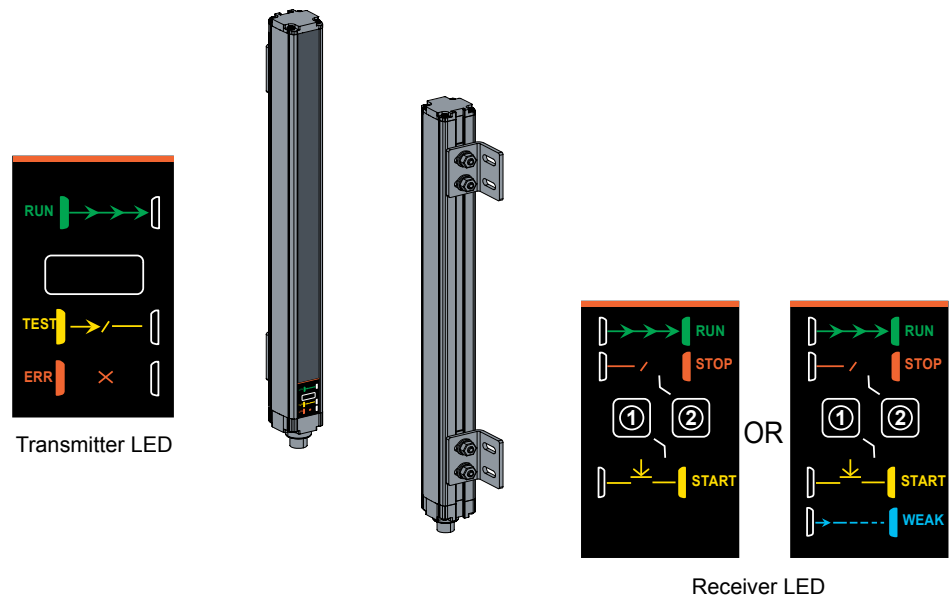

This table describes the LED meanings and output states:

LED Meaning	Transmitter	Receiver		OSSD
		1	2	
Initiation test power- On	Red	Yellow	Red	OFF
Normal operation	Green	OFF	Green	ON
Detection zone interrupted	Green	OFF	Red	OFF
Detection zone clear, waiting for restart	Green	Yellow	OFF	OFF
Detection zone clear, waiting for K1_K2 feedback	Green	Yellow flashes	Yellow flashes	OFF
Test state (simulation of a detection zone interruption)	Orange	OFF	Red	OFF
Weak signal (low signal received) only with type 4 finger detection and long range models	Green	Blue and/or Yellow (*)	Green, yellow or red (*)	(*)
Primary: Detection zone clear Secondary: Detection zone interrupted	Green	Yellow flashes	Red	OFF
Fail mode (Error state) For more information, refer to <a href="#">Troubleshooting section, page 73</a> .	Red flashes	OFF	Red flashes	OFF

\* Refer to the table for blue states given below.

This table provides the the meaning of the blue LED:

Blue States	Receiver				OSSD
	1		2		
Normal operation with weak signal	Blue		Green		ON
Detection zone clear waiting for restart with weak signal	Blue/Yellow alternate		OFF		OFF
Detection zone interrupted with weak signal	Blue		Red		OFF
Detection zone clear waiting for K1_K2 feedback with weak signal	Yellow	Alternate flashes	Yellow	Alternate	OFF
	Blue	OFF			

## Aligning the Transmitter and Receiver

### General Description

The transmitter and receiver must be installed with the optical surfaces face to face, connectors oriented in the same way. Perfect alignment of the transmitter and the receiver corresponding beams is mandatory for an optimum functioning, meaning that the transmitter and receiver must have the same height and be parallel. A good positioning will be facilitated by using the provided mounting accessories.

This figure describes the alignment of the transmitter and receiver:

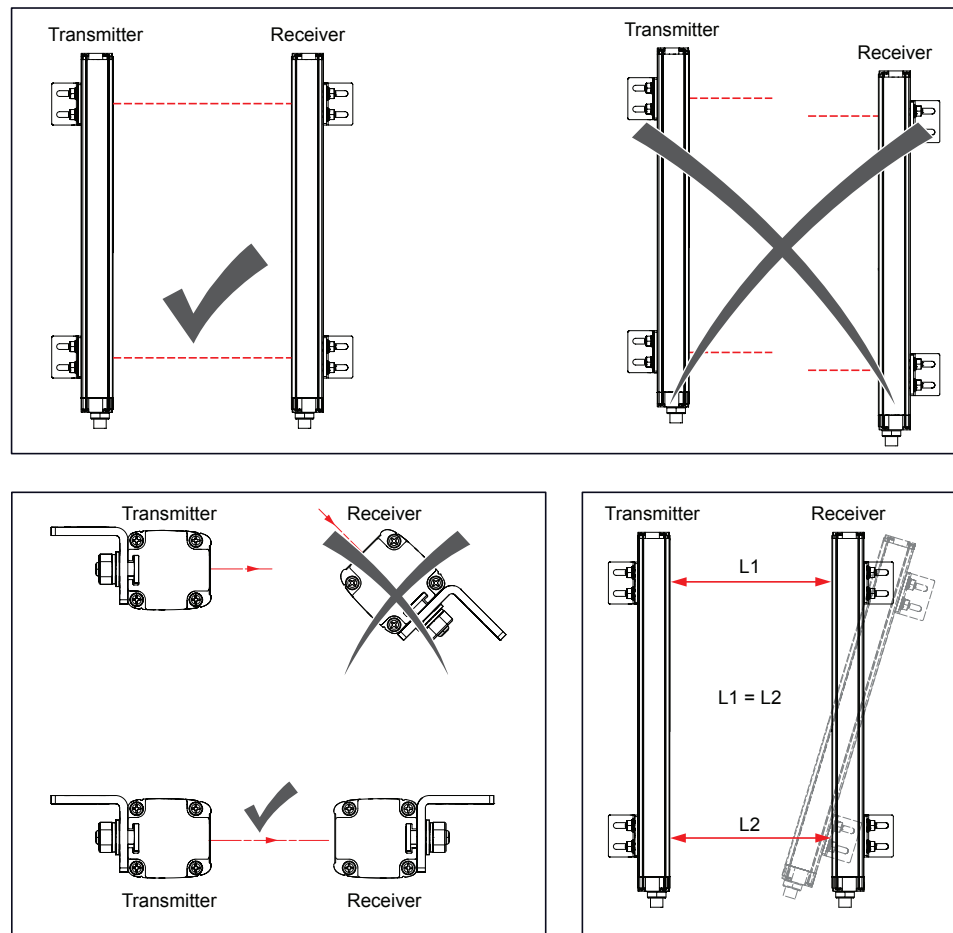

### Receiver LED Indicator

The use of LED indicators helps in proper alignment as described below:

- For all models align the transmitter until the green LED is lit on the receiver .
- For finger detection and long range models, the blue LED weak signal on the receiver will be useful as well. Firstly, find the zone where the blue LED is lit, indicating an approximate alignment, then fine-tune the setting until the blue LED turns OFF and the green LED is lit.
- For alignment help, you can also use a [laser pointer device, page 99](#).

**NOTE :** For an easier alignment setting, configure the safety light curtain in Automatic mode. That will avoid to restart the system during the alignment adjustments. After the alignment and fixing operations, do not forget to reconfigure the safety light curtain in Manual start mode if it is the requested operating mode.

## Alignment with XUSZLPE laser pointer

When using a laser pointer for the alignment, start to point the middle of the safety light curtain for a first adjustment, then point the top and the bottom.

The laser pointer must properly sit flat against the optical window during the alignment.

# Troubleshooting

## What's in This Part

Receiver and Transmitter Troubleshooting.....	75
---	----

## Overview

This section provides information about the diagnostic and test features and transmitter and receiver troubleshooting.

# Receiver and Transmitter Troubleshooting

## What's in This Chapter

Transmitter Troubleshooting .....	75
Receiver Troubleshooting .....	76

## Overview

This chapter describes the receiver and transmitter troubleshooting in detail.

## Transmitter Troubleshooting

### Troubleshooting

This table describes the transmitter troubleshooting:

LED Color	Behavior	Meaning	Troubleshooting
Red	2 successive flashes	Incorrect connection of pins 2 and 4.	Check connections of pins 2 and 4.
Red	3 or 4 successive flashes	Internal failure detected.	Contact the customer support in your country.
Red	5 successive flashes	Primary and secondary segment not compatible.	Check the compatibility of the primary and secondary models.
Orange	Flashes	Waiting for primary/secondary communication (indication available only on secondary light curtains).	Check the primary status. If in the fail mode, check the detected failure type. If the failure found persists, contact customer support in your country.
Orange	2 successive flashes	Primary/secondary communication interruption (indication available only on primary and secondary light curtains).	Check primary/secondary connections. Restart the system. If the failure found persists, contact customer support in your country.

# Receiver Troubleshooting

## Troubleshooting

This table describes the receiver troubleshooting:

LED Color	Behavior	Meaning	Troubleshooting
Red	2 successive flashes	Incorrect configuration.	Check connections.
Red	4 successive flashes	Interfering transmitter detected.	Locate the interfering source and implement one of the following options: <ul style="list-style-type: none"> <li>• Reduce the range of interfering transmitter from high to low.</li> <li>• Move the interfering source in an area where it does not illuminate the receiver.</li> <li>• Use a piece of opaque material as optical shield between the interfering source and the interfered receiver.</li> </ul>
Red	5 successive flashes	OSSD outputs failure detected.	Check connections If the failure found persists, contact customer support in your country.
Red	6 or 7 successive flashes	Internal failure detected.	Contact customer support in your country.
Red	8 successive flashes	Incorrect primary/secondary connections (indication available only on primary and secondary 2 light curtains).	Check primary/secondary connections If the failure found persists, contact customer support in your country.

# Technical Characteristics

## What's in This Part

Technical Characteristics .....	78
---------------------------------	----

## Overview

This section provides information about the technical characteristics.

# Technical Characteristics

## What's in This Chapter

Light Curtain Specifications .....	78
Response Time and Safety Related Data .....	82
Dimensions and Weights .....	88
Accessories .....	90

## Overview

This chapter describes the technical characteristics of the XUSL2E/XUSL4E light curtain system.

## Light Curtain Specifications

### Conformity/Approvals

The given table provides the standards and approvals:

<b>Conforming to standards - XUSL2E</b>	Type 2 (IEC 61496-1), SIL 1 (IEC 61508), SILCL 1 (IEC 62061), PLc-Cat.2 (ISO 13849-1)
<b>Conforming to standards - XUSL4E</b>	Type 4 (IEC 61496-1), SIL 3 (IEC 61508), SILCL 3 (IEC 62061), PLe-Cat.4 (IEC 13849-1)
<b>Approvals</b>	cULus, CE/TUV

### Temperature Range Specifications

The given table provides the temperature range specifications

Ref Telemecanique	Models	Sensing Range	Resolution	Temperature range	
				Operating	Storage
XUSL•E30H•••N <sup>1</sup> XUSL•E•BB•••N <sup>1</sup>	Type 2 and Type 4 Standard models and Type 4 cascable models	Normal sensing range	30 mm (1.18 in)	-30...55 °C	-35...70 °C -31...158 °F
2-3-4 beams			-22...131 °F		
XUSL4E14F•••N <sup>1</sup>	Type 4 Standard models and Type 4 cascable models		14 mm (0.55 in)	-20...55 °C -4...131 °F	
XUSL4E30H•••L XUSL4E•BB•••L	Type 4 Standard models	Long sensing range	30 mm (1.18 in) 2-3-4 beams		

Ref Telemecanique	Models	Sensing Range	Resolution	Temperature range	
				Operating	Storage
XUSL2E30H***NWC	Type 2 IP69K without heating system	Normal sensing range	30 mm (1.18 in)	-30...55 °C	-30...70 °C -22...158 °F
XUSL2E30H***NWH	Type 2 IP69K with heating system		30 mm (1.18 in)	-22...131 °F	
XUSL4E14F***NWC	Type 4 IP69K without heating system	Normal sensing range	14 mm (0.55 in)	-20...55 °C	-30...55 °C -22...131 °F
XUSL4E14F***NWH	Type 4 IP69K with heating system			-4...131 °F	
XUSL4E30H***LWC	Type 4 IP69K without heating system	Long sensing range	30 mm (1.18 in)	-20...55 °C	-30...55 °C -22...131 °F
XUSL4E*BB***LWC			2-3-4 beams	-4...131 °F	
XUSL4E30H***LWH	Type 4 IP69K with heating system		30 mm (1.18 in)	-30...55 °C	
XUSL4E*BB***LWH			2-3-4 beams	-22...131 °F	

1 Applicable also for references ending with NM, NS1, and NS2

## Environmental Specifications

The given table provides the temperature range specifications

The given table provides the environmental specifications:

Environmental Characteristics		Description
Degree of protection*	–	IP65 - IP67 and IP69K with special enclosure
Resistance to shock and vibration	–	In accordance with IEC 61496-1: <ul style="list-style-type: none"> <li>Shock: 10g</li> <li>Impulse: 16 ms</li> <li>Vibration: 10...55 Hz</li> <li>Amplitude: 0.35 ± 0.05 mm (0.0014 ± 0.00020 inches)</li> </ul>
Materials	–	Housing: Aluminum Red color: RAL 3000 End caps: Polypropylene Optical front panel: Polycarbonate <b>IP69K Materials:</b> End caps: Stainless steel (AISI 316L)/ Silicone O-Ring Tube: PMMA (Polymethylmethacrylate) ø 50 mm (1.97 inches) Anti-condensation system (integrated GORE™ valve) Cables: PVC
Environmental Chemicals		
Chemical resistance	Aliphatic hydrocarbons	Resistant
	Alcohols	
	Detergents and cleansers	
	Detergents and cleansers containing alkali products	
Environmental Chemicals - IP69K Enclosure		

Environmental Characteristics		Description
Chemical resistance	Alkaline (non-chlorinated) cleaning agents	Resistant
	Acid cleaning agents	
	Aliphatic hydrocarbons	
Environmental resistance	Humidity	
	Weathering (sun, water)	
* Devices are not suitable for outdoor use without supplementary measures		

## Optical Characteristics

The given table provides the optical characteristics:

Optical Characteristics	Unit	Description	
Resolution or beams spacing	mm	Resolution 14 mm	Resolution 30 mm Beam spacing for multibeams 300, 400, and 500 mm, respectively for 4, 3, and 2 beams.
Nominal range	m	0...3 m or 1...6 m 0...2 m or 1...5 m with IP69K enclosure.	0...4 m or 0...12 m selectable (on normal sensing distance models Type 2 and Type 4). 0...10 m or 3...20 m on long sensing distance models (Type 4). 0...8 m or 3...17 m with IP69K enclosure (Type 4). 0...3 m or 3...10 m with IP69K enclosure (Type 2)
Protection heights	mm	160 mm...1810 mm	
Effective aperture angle	–	+/-2.5° maximum, transmitter and receiver at operating range >3 m (9.84 ft) in accordance with IEC 61496-2 (Type 4). +/-5° maximum, transmitter and receiver at operating range >3 m (9.84 ft) in accordance with IEC 61496-2 (Type 2).	
Light source	Nm	Infrared $\lambda = 950 \text{ Nm}$	
Resistance to light disturbance	–	In accordance with IEC 61496-2.	

## Electrical Characteristics

The given table provides the electrical characteristics:

Electrical Characteristics	Unit	Description
Response time	ms	Refer to <a href="#">Response Time and Safety Related Data, page 79</a> .
Power supply	V	24 Vdc $\pm$ 20% 2 A, SELV/PELV The power supply must meet requirements of IEC 61496-1 and IEC 60204-1.
Protection against electric shocks	-	Insulation class III
Maximum current consumption (no load)	mA	Transmitter: 42 mA Receiver: 83 mA
Resistance to interference	–	Level depends if the product is Type 2 or Type 4 in accordance with IEC 61496-1.

Electrical Characteristics	Unit	Description
Input power supply	mA	Transmitter: 42 mA Receiver: 900 mA (Including OSSD current)
Safety outputs (OSSD)	–	Two PNP - 400 mA per output @ 24 Vdc, drop out voltage <0.5 Vdc (Integrated arc suppressors), leakage current (OFF state) < 2 mA. Load capacity 0.82µF under 24 Vdc
Signals	–	Transmitter: 1 three-color LED - Red/Amber/Green Receiver: 2 LEDs - 2 two-colors - Red/Green and Yellow/Blue
Connections	–	Transmitter: 5 pins male M12 connector Receiver: 8 pins male M12 connector For Primary/Secondary configurations, refer to <a href="#">Electrical Connections, page 58</a> .
Cable length	m	Unshielded cable up to 100 m (50 m between Primary and Secondary). Extension cables are available in separate lengths.  For more information, refer to <a href="#">Electrical Connections, page 58</a> .
Cable gauge	mm <sup>2</sup>	0.25 mm <sup>2</sup> (AWG24) for 8 wires cable 0.34 mm <sup>2</sup> (AWG22) for 5 wires cable
First-up time (time delay before availability)	s	2 s Maximum
OSSDs Pulse Duration	µs	200 µs Maximum
OSSDs Pulse Period	ms	2.5 ms minimum (Type 4 models) 500 ms minimum (Type 2 models)
OSSDs classification according to ZVEI (CB24I)	–	CL3

**NOTICE**

**UNINTENDED EQUIPMENT OPERATION**

Check that the OSSDs pulse duration is compatible with the safety control unit.

**Failure to follow these instructions can result in equipment damage.**

## Response Time and Safety Related Data

### General Description

This table provides safety related data for the XUSL2E and XUSL4E Safety light curtains:

Safety Light Curtain	Mission Time (TM)
XUSL2E	20 years
XUSL4E Finger	20 years
XUSL4E Hand/Body	

For Safety related data definitions, refer to glossary.

### XUSL4E Ranges

Telemecanique Reference XUSL4	Protected Height (mm)	No. of Beams (to determine response time)	Response Time t1 (ms)	PFHD (IEC 61508)
<b>Finger Detection Models - Standard Sensing Range</b>				
Resolution (mm) = 14				
Operating Range (m) = 0...3 or 1...6				
XUSL4E14F016N	160	15	4	1.03 x 10 <sup>-8</sup>
XUSL4E14F031N	310	30	5.5	1.27 x 10 <sup>-8</sup>
XUSL4E14F046N	460	45	7.5	1.52 x 10 <sup>-8</sup>
XUSL4E14F061N	610	60	9	1.75 x 10 <sup>-8</sup>
XUSL4E14F076N	760	75	11	2.00 x 10 <sup>-8</sup>
XUSL4E14F091N	910	90	13	2.24 x 10 <sup>-8</sup>
XUSL4E14F106N	1060	105	14.5	2.49 x 10 <sup>-8</sup>
XUSL4E14F121N	1210	120	16.5	2.73 x 10 <sup>-8</sup>
XUSL4E14F136N	1360	135	18	2.98 x 10 <sup>-8</sup>
XUSL4E14F151N	1510	150	20	3.22 x 10 <sup>-8</sup>
XUSL4E14F166N	1660	165	22	3.48 x 10 <sup>-8</sup>
XUSL4E14F181N	1810	180	23.5	3.71 x 10 <sup>-8</sup>
<b>Hand Detection Models - Standard Sensing Range</b>				
Resolution (mm) = 30				
Operating Range (m) = 0...4 or 0...12				
XUSL4E30H016N	160	8	4	7.08 x 10 <sup>-9</sup>
XUSL4E30H026N	260	13	5	8.06 x 10 <sup>-9</sup>
XUSL4E30H031N	310	16	5.5	8.20 x 10 <sup>-9</sup>
XUSL4E30H046N	460	23	7.5	9.47 x 10 <sup>-9</sup>
XUSL4E30H061N	610	31	9	1.06 x 10 <sup>-8</sup>
XUSL4E30H076N	760	38	10.5	1.19 x 10 <sup>-8</sup>
XUSL4E30H091N	910	46	12.5	1.30 x 10 <sup>-8</sup>
XUSL4E30H106N	1060	53	14	1.43 x 10 <sup>-8</sup>
XUSL4E30H121N	1210	61	15.5	1.54 x 10 <sup>-8</sup>
XUSL4E30H136N	1360	68	17	1.67 x 10 <sup>-8</sup>
XUSL4E30H151N	1510	76	19	1.78 x 10 <sup>-8</sup>
XUSL4E30H166N	1660	83	20.5	1.90 x 10 <sup>-8</sup>
XUSL4E30H181N	1810	91	22	2.02 x 10 <sup>-8</sup>

Telemecanique Reference XUSL4	Protected Height (mm)	No. of Beams (to determine response time)	Response Time t1 (ms)	PFHD (IEC 61508)
<b>Hand Detection Models - Long Sensing Range</b>				
Resolution (mm) = 30				
Operating Range (m) = 0...10 or 3...20				
XUSL4E30H016L	160	8	3	9.13 x 10-9
XUSL4E30H031L	310	16	4	1.04 x 10-8
XUSL4E30H046L	460	23	5	1.16 x 10-8
XUSL4E30H061L	610	31	6	1.28 x 10-8
XUSL4E30H076L	760	38	6.5	1.41 x 10-8
XUSL4E30H091L	910	46	7.5	1.53 x 10-8
XUSL4E30H106L	1060	53	8.5	1.66 x 10-8
XUSL4E30H121L	1210	61	9.5	1.78 x 10-8
XUSL4E30H136L	1360	68	10	1.91 x 10-8
XUSL4E30H151L	1510	76	11	2.03 x 10-8
XUSL4E30H166L	1660	83	12	2.16 x 10-8
XUSL4E30H181L	1810	91	13	2.29 x 10-8
<b>Finger Detection Models - Standard Sensing Range with IP69K Enclosure (without heating system)</b>				
Resolution (mm) = 14				
Operating Range (m) = 0...2 or 1...5				
XUSL4E14F031NWC	310	30	5.5	1.27 x 10-8
XUSL4E14F046NWC	460	45	7.5	1.52 x 10-8
XUSL4E14F061NWC	610	60	9	1.75 x 10-8
XUSL4E14F076NWC	760	75	11	2.00 x 10-8
<b>Hand Detection Models - Long Sensing Range with IP69K Enclosure (without heating system)</b>				
Resolution (mm) = 30				
Operating Range (m) = 0...8 or 3...17				
XUSL4E30H046LWC	460	23	7.5	1.16 x 10-8
XUSL4E30H061LWC	610	31	9	1.28 x 10-8
XUSL4E30H076LWC	760	38	10.5	1.41 x 10-8
XUSL4E30H091LWC	910	46	12.5	1.53 x 10-8
XUSL4E30H106LWC	1060	53	14	1.66 x 10-8
<b>Finger Detection Models - Standard Sensing Range with IP69K Enclosure (with heating system)</b>				
Resolution (mm) = 14				
Operating Range (m) = 0...2 or 1...5				
XUSL4E14F031NWH	310	30	5.5	1.27 x 10-8
XUSL4E14F046NWH	460	45	7.5	1.52 x 10-8
XUSL4E14F061NWH	610	60	9	1.75 x 10-8
XUSL4E14F076NWH	760	75	11	2.00 x 10-8
<b>Hand Detection Models - Long Sensing Range with IP69K Enclosure (with heating system)</b>				
Resolution (mm) = 30				
Operating Range (m) = 0...8 or 3...17				
XUSL4E30H046LWH	460	23	7.5	1.16 x 10-8
XUSL4E30H061LWH	610	31	9	1.28 x 10-8
XUSL4E30H076LWH	760	38	10.5	1.41 x 10-8
XUSL4E30H091LWH	910	46	12.5	1.53 x 10-8
XUSL4E30H106LWH	1060	53	14	1.66 x 10-8

Telemechanique Reference XUSL4	Protected Height (mm)	No. of Beams (to determine response time)	Response Time t1 (ms)	PFHD (IEC 61508)
<b>Finger Detection Models - Standard Sensing Range - Primary segment</b>				
Resolution (mm) = 14				
Operating Range (m) = 0...3 or 1...6				
XUSL4E14F031NM	310	30	Refer to Response Time Calculation, page 85.	1.27 x 10 <sup>-8</sup>
XUSL4E14F046NM	460	45		1.52 x 10 <sup>-8</sup>
XUSL4E14F061NM	610	60		1.75 x 10 <sup>-8</sup>
XUSL4E14F076NM	760	75		2.00 x 10 <sup>-8</sup>
<b>Hand Detection Models - Standard Sensing Range - Primary segment</b>				
Resolution (mm) = 30				
Operating Range (m) = 0...4 or 0...12				
XUSL4E30H046NM	460	16	Refer to Response Time Calculation, page 85	9.47 x 10 <sup>-9</sup>
XUSL4E30H061NM	610	23		1.06 x 10 <sup>-8</sup>
XUSL4E30H076NM	760	31		1.19 x 10 <sup>-8</sup>
XUSL4E30H091NM	910	38		1.30 x 10 <sup>-8</sup>
XUSL4E30H106NM	1060	46		1.43 x 10 <sup>-8</sup>
<b>Finger Detection Models - Standard Sensing Range - Secondary segment 1</b>				
Resolution (mm) = 14				
Operating Range (m) = 0...3 or 1...6				
XUSL4E14F031NS1	310	30	Refer to Response Time Calculation, page 85.	1.27 x 10 <sup>-8</sup>
XUSL4E14F046NS1	460	45		1.52 x 10 <sup>-8</sup>
XUSL4E14F061NS1	610	60		1.75 x 10 <sup>-8</sup>
XUSL4E14F076NS1	760	75		2.00 x 10 <sup>-8</sup>
<b>Hand Detection Models - Standard Sensing Range - Secondary segment 1</b>				
Resolution (mm) = 30				
Operating Range (m) = 0...4 or 0...12				
XUSL4E30H046NS1	460	23	Refer to Response Time Calculation, page 85	9.47 x 10 <sup>-9</sup>
XUSL4E30H061NS1	610	31		1.06 x 10 <sup>-8</sup>
XUSL4E30H076NS1	760	38		1.19 x 10 <sup>-8</sup>
XUSL4E30H091NS1	910	46		1.30 x 10 <sup>-8</sup>
XUSL4E30H106NS1	1060	53		1.43 x 10 <sup>-8</sup>
<b>Finger Detection Models - Standard Sensing Range - Secondary segment 2</b>				
Resolution (mm) = 14				
Operating Range (m) = 0...3 or 1...6				
XUSL4E14F046NS2	460	45	Refer to Response Time Calculation, page 85.	1.52 x 10 <sup>-8</sup>
XUSL4E14F061NS2	610	60		1.75 x 10 <sup>-8</sup>
XUSL4E14F076NS2	760	75		2.00 x 10 <sup>-8</sup>
<b>Hand Detection Models - Standard Sensing Range - Secondary segment 2</b>				
Resolution (mm) = 30				
Operating Range (m) = 0...4 or 0...12				
XUSL4E30H046NS2	460	23	Refer to Response Time Calculation, page 85.	9.47 x 10 <sup>-9</sup>
XUSL4E30H061NS2	610	31		1.06 x 10 <sup>-8</sup>
XUSL4E30H076NS2	760	38		1.19 x 10 <sup>-8</sup>
XUSL4E30H091NS2	910	46		1.30 x 10 <sup>-8</sup>
XUSL4E30H106NS2	1060	53		1.43 x 10 <sup>-8</sup>

Telemecanique Reference XUSL4	Space between beams	Protected Height (mm)	No. of Beams (to determine response time)	Response Time t1 (ms)	PFHD (IEC 61508)
<b>Body Detection Models - Standard Sensing Range</b>					
Operating Range (m) = 0...4 or 0...12					
XUSL4E2BB051N	500	510	2	2.5	6.89 x 10-9
XUSL4E3BB081N	400	810	3	3	7.55 x 10-9
XUSL4E4BB091N	300	910	4	3	8.21 x 10-9
<b>Body Detection Models - Long Sensing Range</b>					
Operating Range (m) = 0...10 or 3...20					
XUSL4E2BB051L	500	510	2	2.5	9.15 x 10-9
XUSL4E3BB081L	400	810	3	3	9.99 x 10-9
XUSL4E4BB091L	300	910	4	3	1.08 x 10-8
<b>Body Detection Models - Long Sensing Range with IP69K Enclosure (without heating system)</b>					
Operating Range (m) = 0...8 or 3...17					
XUSL4E2BB051LWC	500	510	2	2.5	9.15 x 10-9
XUSL4E3BB081LWC	400	810	3	3	9.99 x 10-9
XUSL4E4BB091LWC	300	910	4	3	1.08 x 10-8
<b>Body Detection Models - Long Sensing Range with IP69K Enclosure (with heating system)</b>					
Operating Range (m) = 0...8 or 3...17					
XUSL4E2BB051LWH	500	510	2	2.5	9.15 x 10-9
XUSL4E3BB081LWH	400	810	3	3	9.99 x 10-9
XUSL4E4BB091LWH	300	910	4	3	1.08 x 10-8
<b>Body Detection Models - Standard Sensing Range - Primary segment</b>					
Operating Range (m) = 0...4 or 0...12					
XUSL4E2BB051NM	500	510	2	Refer to <a href="#">Response Time Calculation, page 85</a>	6.89 x 10-9
XUSL4E3BB081NM	400	810	3		7.55 x 10-9
XUSL4E4BB091NM	300	910	4		8.21 x 10-9
<b>Body Detection Models - Standard Sensing Range - Secondary segment 1</b>					
Operating Range (m) = 0...4 or 0...12					
XUSL4E2BB051NS1	500	510	2	Refer to <a href="#">Response Time Calculation, page 85.</a>	6.89 x 10-9
XUSL4E3BB081NS1	400	810	3		7.55 x 10-9
XUSL4E4BB091NS1	300	910	4		8.21 x 10-9
<b>Body Detection Models - Standard Sensing Range - Secondary segment 2</b>					
Operating Range (m) = 0...4 or 0...12					
XUSL4E2BB051NS2	500	510	2	Refer to <a href="#">Response Time Calculation, page 85.</a>	6.89 x 10-9
XUSL4E3BB081NS2	400	810	3		7.55 x 10-9
XUSL4E4BB091NS2	300	910	4		8.21 x 10-9

## XUSL2E Ranges

Telemecanique Reference XUSL2	Protected Height (mm)	No. of Beams to determine response time	Response Time t1 (ms)	PFHD (IEC 61508)	
<b>Hand Detection Models - Standard Sensing Range</b>					
Resolution (mm) = 30					
Operating Range (m) = 0...4 or 0...12					
XUSL2E30H016N	160	8	4.5	2.04 x 10 <sup>-8</sup>	
XUSL2E30H026N	260	13	6	2.55 x 10 <sup>-8</sup>	
XUSL2E30H031N	310	16	6	2.66 x 10 <sup>-8</sup>	
XUSL2E30H046N	460	23	8	3.30 x 10 <sup>-8</sup>	
XUSL2E30H061N	610	31	10	3.92 x 10 <sup>-8</sup>	
XUSL2E30H076N	760	38	11	4.57 x 10 <sup>-8</sup>	
XUSL2E30H091N	910	46	13	5.19 x 10 <sup>-8</sup>	
XUSL2E30H106N	1060	53	14.5	5.83 x 10 <sup>-8</sup>	
XUSL2E30H121N	1210	61	16	6.45 x 10 <sup>-8</sup>	
XUSL2E30H136N	1360	68	17.5	7.09 x 10 <sup>-8</sup>	
XUSL2E30H151N	1510	76	19.5	7.71 x 10 <sup>-8</sup>	
XUSL2E30H166N	1660	83	21	8.35 x 10 <sup>-8</sup>	
XUSL2E30H181N	1810	91	22.5	8.98 x 10 <sup>-8</sup>	
<b>Hand Detection Models - Standard Sensing Range with IP69K Enclosure (without heating system)</b>					
Resolution (mm) = 30					
Operating Range (m) = 0...3 or 3...10					
XUSL2E30H046NWC	460	23	8	3.30 x 10 <sup>-8</sup>	
XUSL2E30H061NWC	610	31	10	3.92 x 10 <sup>-8</sup>	
XUSL2E30H076NWC	760	38	11	4.57 x 10 <sup>-8</sup>	
XUSL2E30H091NWC	910	46	13	5.19 x 10 <sup>-8</sup>	
XUSL2E30H106NWC	1060	53	14.5	5.83 x 10 <sup>-8</sup>	
<b>Hand Detection Models - Standard Sensing Range with IP69K Enclosure (with heating system)</b>					
Resolution (mm) = 30					
Operating Range (m) = 0...3 or 3...10					
XUSL2E30H046NWH	460	23	8	3.30 x 10 <sup>-8</sup>	
XUSL2E30H061NWH	610	31	10	3.92 x 10 <sup>-8</sup>	
XUSL2E30H076NWH	760	38	11	4.57 x 10 <sup>-8</sup>	
XUSL2E30H091NWH	910	46	13	5.19 x 10 <sup>-8</sup>	
XUSL2E30H106NWH	1060	53	14.5	5.83 x 10 <sup>-8</sup>	
Telemecanique Reference XUSL2	Space between beams	Protected Height (mm)	No. of Beams to determine response time	Response Time t1 (ms)	PFHD (IEC 61508)
<b>Body Detection Models - Standard Sensing Range</b>					
Operating Range (m) = 0...4 or 0...12					
XUSL2E2BB051N	500	510	2	3	1.71 x 10 <sup>-8</sup>
XUSL2E3BB081N	400	810	3	3.5	1.87 x 10 <sup>-8</sup>
XUSL2E4BB091N	300	910	4	3.5	2.02 x 10 <sup>-8</sup>

## Response Time Calculation

<b>Response time for Type 4 Primary/secondary system</b>	14 mm	$R_{ttot} = [0.06 \times (Nb_{secondary1} + Nb_{primary}) + 0.9636] \times 2$
		$R_{ttot} = [0.06 \times (Nb_{secondary1} + Nb_{secondary2} + Nb_{primary}) + 1.0036] \times 2$
	30 mm and multiple beams	$R_{ttot} = [0.11 \times (Nb_{secondary1} + Nb_{primary}) + 0.9376] \times 2$
		$R_{ttot} = [0.11 \times (Nb_{secondary1} + Nb_{secondary2} + Nb_{primary}) + 1.0508] \times 2$

where:

<b>Nb</b>	number of beams
<b>R<sub>ttot</sub></b>	total response time

## Total PFH<sub>D</sub> Calculation

To calculate the entire reliability data, consider every segment (for example, the PFH<sub>D</sub> must be added: **PFH<sub>D</sub> total = PFH<sub>D</sub> primary + PFH<sub>D</sub> secondary 1 + PFH<sub>D</sub> secondary 2**).

Refer to SIL IEC 62061 for more information.

# Dimensions and Weights

## XUSL4E/XUSL2E Dimensions

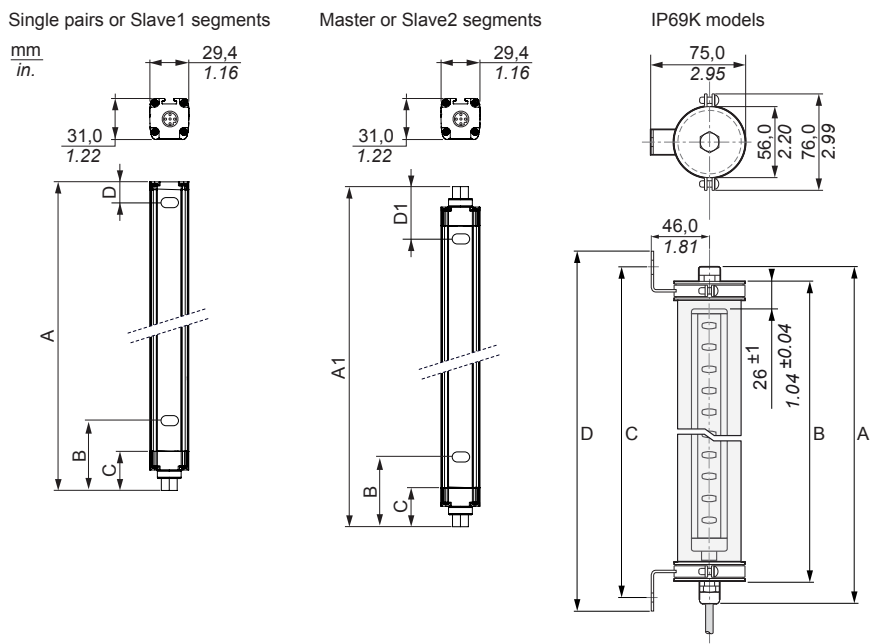

Single Pair or Secondary Segment 1 Dimensions (in mm)

XUSL•E	A	B	C	D	Protected Height	Weight (kg)
XUSL•E•••016	213	61.5	29.5	11	160	0.4
XUSL•E•••026	313				260	0.6
XUSL•E•••031	363				310	0.7
XUSL•E•••046	513				460	1
XUSL•E•••061	663				610	1.2
XUSL•E•••076	813				760	1.5
XUSL•E•••091	963				910	1.7
XUSL•E•••106	1113				1060	2
XUSL•E•••121	1263				1210	2.3
XUSL•E•••136	1413				1360	2.5
XUSL•E•••151	1563				1510	2.8
XUSL•E•••166	1713				1660	3
XUSL•E•••181	1863				1810	3.3
<b>Body detection</b>						
2 beams	653	102	29.5	51	510	1.1
3 beams	953				810	1.6
4 beams	1053				910	1.7

**Primary or Secondary Segment 2 Dimensions (in mm)**

XUSL•E	A1 (Primary/Secondary)	B	C	D1 (Primary/Secondary)	Protected Height	Weight (kg)
XUSL•E•••016	236.5	61.5	29.5	34.5	160	0.42
XUSL•E•••031	386.5				310	0.72
XUSL•E•••046	536.5				460	1.02
XUSL•E•••061	686.5				610	1.22
XUSL•E•••076	836.5				760	1.52
XUSL•E•••091	986.5				910	1.72
XUSL•E•••106	1136.5				1060	2.02
XUSL•E•••121	1286.5				1210	2.32
XUSL•E•••136	1436.5				1360	2.52
XUSL•E•••151	1586.5				1510	2.82
XUSL•E•••166	1736.5				1660	3.02
XUSL•E•••181	1886.5				1810	3.32
<b>Body detection</b>						
2 beams	677	102	29.5	75	510	1.12
3 beams	977				810	1.62
4 beams	1077				910	1.72

**IP69K Model Dimensions (in mm)**

XUSL•E	A	B	C	D	Protected Height	Weight (kg)
XUSL•E•••016	320	290	315	337	160	3.05
XUSL•E•••031	470	440	465	487	310	3.56
XUSL•E•••046	620	590	615	637	460	4.05
XUSL•E•••061	770	740	765	787	610	4.56
XUSL•E•••076	920	890	915	937	760	5.05
XUSL•E•••091	1070	1040	1065	1087	910	5.55
XUSL•E•••106	1220	1190	1215	1237	1060	6.06
XUSL•E•••121	1370	1340	1365	1387	1210	6.56
XUSL•E•••136	1520	1490	1515	1537	1360	7.07
XUSL•E•••151	1670	1640	1665	1687	1510	7.56
XUSL•E•••166	1820	1790	1815	1837	1660	8.05
XUSL•E•••181	1970	1940	1965	1987	1810	8.56
<b>Body detection</b>						
2 beams	760	730	755	777	510	3.81
3 beams	1060	1030	1055	1077	810	4.43
4 beams	1160	1130	1155	1177	910	4.66

## Accessories

### Power Supply

The power supply must meet the requirements of IEC 60204-1 and IEC 61496-1. The SELV part number ABL8RPS24\*\*\* is recommended.

This figure describes the power supply ABL8RPS24\*\*\*:

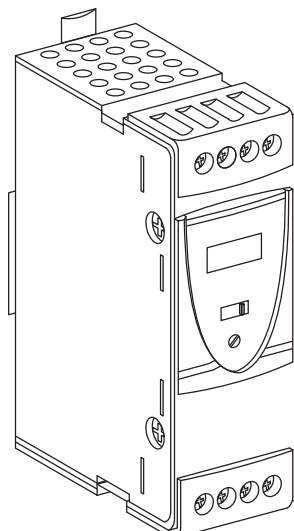

**ABL8RPS24\*\*\* Operating temperature range -25...60 °C without derating:**

Input voltage	Secondary			Reset	Conforming to standard EN 61000-3-2	Reference
	Output voltage (V)	Nominal power (W)	Nominal current (A)			
Single to phase (N-L1) 100...120 Vac -15 +10% (50 Hz or 60 Hz)	24...28.8	72	3	Auto/Manual	Yes	ABL8RP-S24030
		120	5	Auto/Manual	Yes	ABL8RP-S24050
		240	10	Auto/Manual	Yes	ABL8RP-S24100
Phase to phase (L1-L2) 200...500 Vac -15 +10% (50 Hz or 60 Hz)						

### Fixing Brackets

Fixing brackets given below are provided with the safety light curtain pairs and segments.

This figure describes these fixing brackets:

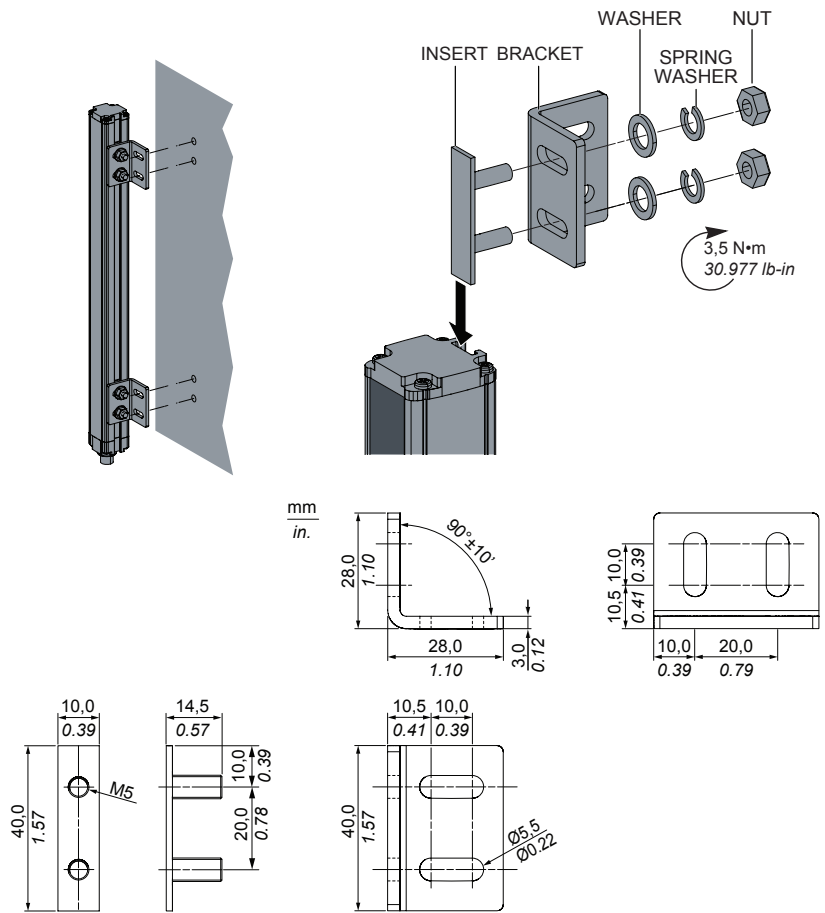

## Special Fixing Brackets

Special brackets are suitable for adaptation of the existing mechanical support, long range applications, or with deflective mirrors.

This table describes the different types of brackets:

Bracket type	Description	Figure
Curved	Allows the rotation over 14° along longitudinal axis of the safety light curtain.	<p>Exploded view of the curved bracket assembly showing the following components: INSERT, CURVE BRACKET, PLATE, WASHER, SPRING WASHER, and NUT. The assembly is shown being mounted onto a vertical rail. A torque specification of 3.5 N.m (30.977 lb-in) is indicated for the nuts.</p> <p>Technical drawings include:</p> <ul style="list-style-type: none"> <li>A side view of the curved bracket with dimensions: 28.0 mm (1.10 in) height, 30.0 mm (1.18 in) width, 3.0 mm (0.12 in) thickness, 15.5 mm (0.61 in) offset, and a 90°±10° angle.</li> <li>A top view of the bracket with dimensions: 10.5 mm (0.41 in) height, 10.0 mm (0.39 in) width, and 20.0 mm (0.79 in) width.</li> <li>A side view of the plate with dimensions: 40.0 mm (1.57 in) height, 10.0 mm (0.39 in) width, and 7.5 mm (0.30 in) width.</li> <li>A perspective view of the assembly with a 7° angle.</li> </ul>
Swivel	Allows the rotation over 180° along longitudinal axis of the safety light curtain.	<p>Exploded view of the swivel bracket assembly showing the following components: SWIVEL BRACKET, PIVOT, INSERT, WASHER, and NUT. The assembly is shown being mounted onto a vertical rail. Two torque specifications are indicated: 4 N.m (35.403 lb-in) for the top nut and 3.5 N.m (30.977 lb-in) for the bottom nut.</p> <p>Technical drawings include:</p> <ul style="list-style-type: none"> <li>A side view of the swivel bracket with dimensions: 24.0 mm (0.94 in) height, 18.0 mm (0.71 in) width, 3.0 mm (0.12 in) thickness, 34.0 mm (1.34 in) offset, and 6.0 mm (0.24 in) offset.</li> <li>A top view of the bracket with dimensions: 28.0 mm (1.10 in) height, 14.0 mm (0.55 in) width, 8.0 mm (0.31 in) offset, 16.0 mm (0.62 in) offset, 28.0 mm (1.10 in) width, and 16.0 mm (0.63 in) width.</li> <li>A side view of the pivot with dimensions: 10.0 mm (0.39 in) height, 20.0 mm (0.79 in) width, and 3.0 mm (0.12 in) thickness.</li> <li>A perspective view of the assembly with a 90° angle.</li> </ul>

This table provides the references of the special fixing brackets:

Reference	Maximum Protected Height (mm)	Description	Weight (Kg)
XUSZBSC4	160–1060	Curved bracket, 4 fixing brackets set	0.20
XUSZBSC6	1060–1810	Curved bracket, 6 fixing brackets set	0.30
XUSZBSS4	160–1810	Swivel bracket, endcaps brackets, 4 fixing brackets set	0.15

## Vibration Dampers Kit

The vibration dampers kit is used to isolate transmitters and receivers from sources of vibration and shock. The anti-vibration kit comprises of 4, 8, or 12 dampers.

This figure displays the vibration dampers kit:

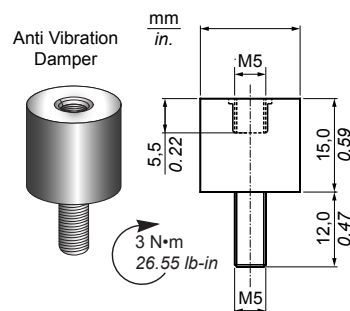

This table describes the references, the minimum dampers needed depending on the height of the safety light curtain and the number of dampers (included in kit references):

Description	Reference	For use with	Maximum protected height (mm)	Number of dampers	Weight (kg)
Anti-vibration kits comprising 4, 8, or 12 dampers.	XUSZVA4	All types of safety light curtains	160	4	0.05
	XUSZVA8		260–1060	8	0.10
	XUSZVA12		1210–1810	12	0.15

This figure describes the mounting of light curtains with vibration dampers:

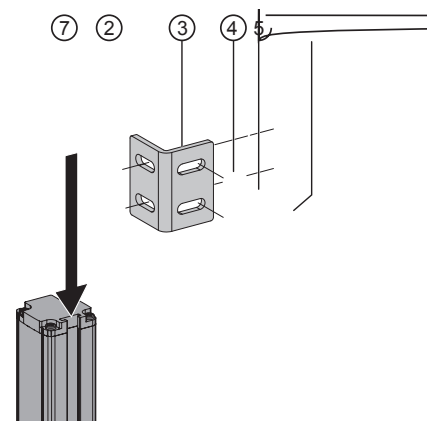

## Fixing Base

The columns fixing base system allows a robust mounting on the floor with a possibility to adjust the transmitter and receiver alignment accurately.

This figure displays the simple column fixing base:

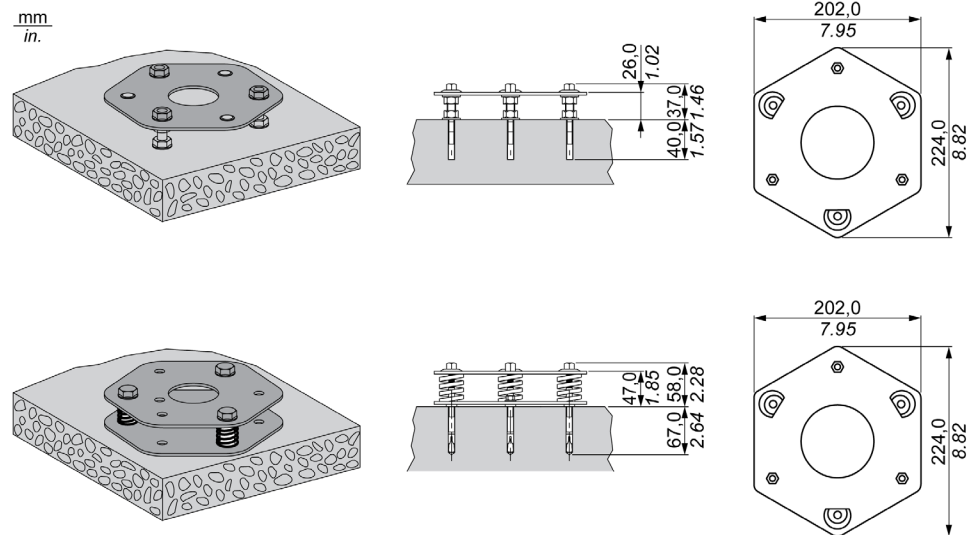

This table describes the environmental characteristics and references of the column fixing base:

Column fixing base				
References				
One fixing base has to be ordered for each column.	Reference	Height (mm)	Dimensions	Weight (kg)
	XUSZFB2	47	202 x 224 x 58 h	2.2
	(Double fixing base)			
	XUSZFB1	26	202 x 224 x 37 h	1.0
	(Simple fixing base)			

The double plate is particularly suitable for mounting with [columns, page 92](#) (with or without mirror). The positioning setting is facilitated by the springs and adjustment screws.

## Column

Columns are used to protect safety light curtain systems in case of shock or flying part risks in the application. Columns are also available with pre-installed deflective mirrors. A built-in spirit level form a useful help for vertical axis positioning.

This figure describes the fixing columns without mirror:

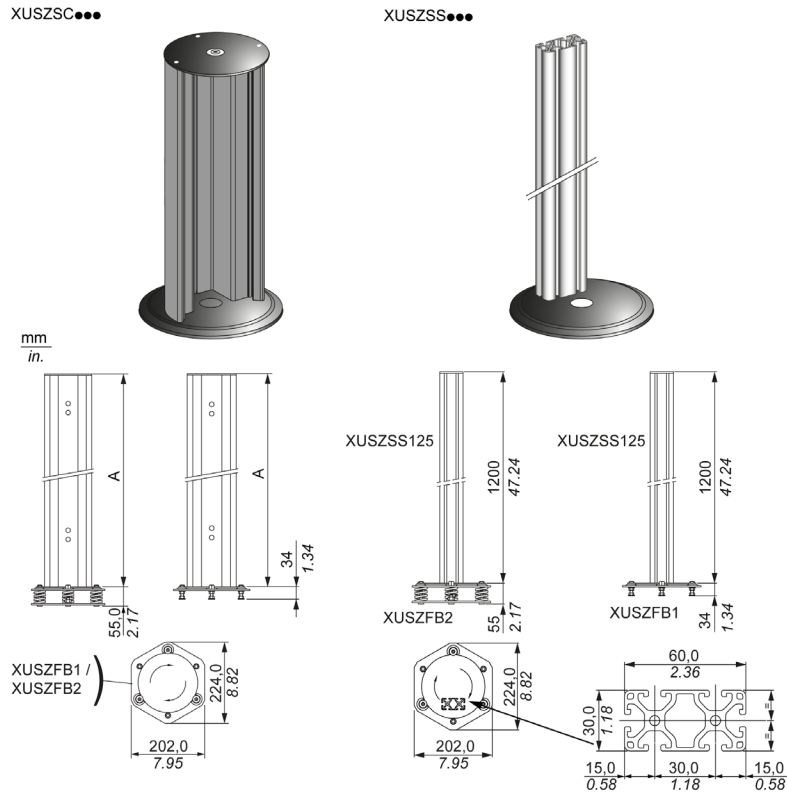

**NOTE :** The use of straight connectors for the Transmitter and Receiver connection is mandatory when using protection columns XUSZS... (90°connectors are not suitable).

The columns must be mounted on XUSZFB1 or XUSZFB2 floor mounting bases (to be ordered separately).

This figure displays the distance between the first beam and the floor (H) (According to ISO 13855):

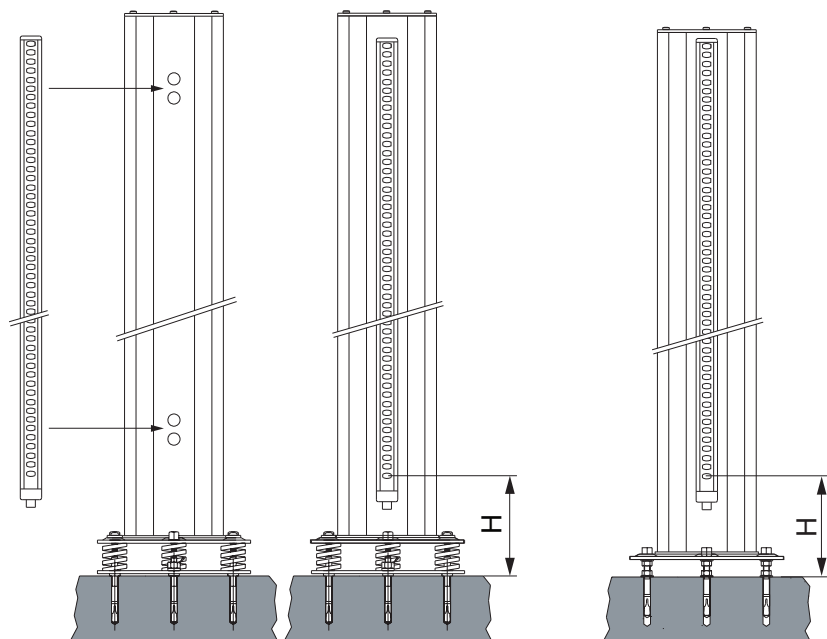

This table describes the distance between the first beam and floor (H):

Reference	H (mm)
XUSZSC105	400 (15.75 in.)
XUSZSC105R	
XUSZSC138	300 (11.81 in.)
XUSZSC138R	
XUSZSC172	300 (11.81 in.)
XUSZSC172R	
XUSZSC202	300 (11.81 in.)
XUSZSC202R	
* For the lowest beam, 400 mm can only be used when the risk assessment allows it.	

This table describes the references of the fixing column without mirror:

Fixing columns for Safety Light Curtains					
Reference - Column (without mirror)					
Fixing base column has to be ordered for each column.	Reference	For use with light curtains	Height (A) (mm)	Maximum protected height (mm)	Weight (kg)
	XUSZSC105	XUSL•E•••016...L•E•••061	1000	610 or 2 beams	3.5
	XUSZSC138	XUSL•E•••076...L•E•••106	1330	1060 or 3 and 4 beams	4.4
	XUSZSC172	XUSL•E•••121...L•E•••136	1670	1360	5.3
	XUSZSC202	XUSL•E•••151...L•E•••181	1970	1810	6.0
	XUSZSC105R*	XUSL•E•••016...L•E•••061	1000	610 or 2 beams	3.7
	XUSZSC138R*	XUSL•E•••076...L•E•••106	1330	1060 or 3 and 4 beams	4.5
	XUSZSC172R*	XUSL•E•••121...L•E•••136	1670	1360	5.5
	XUSZSC202R*	XUSL•E•••151...L•E•••181	1970	1810	6.2
	XUSZSS125	XUSL•E•••016...L•E•••121	1200	1210	1.3
* with cable gland entry PG11.					

This figure describes the fixing columns with mirror:

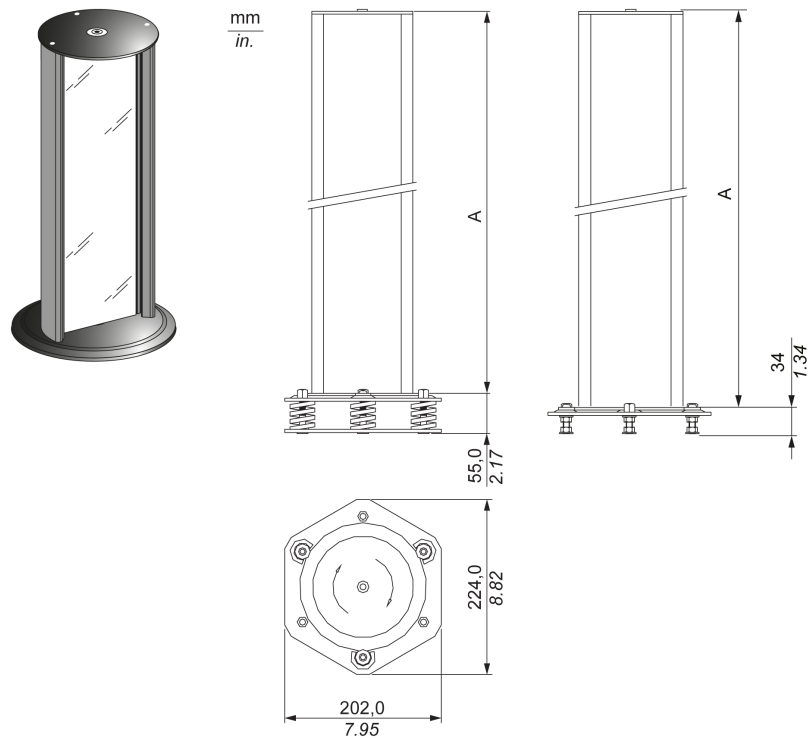

The columns with mirrors must be mounted on XUSZFB1 or XUSZFB2 floor mounting bases (to be ordered separately).

This table describes the references of the fixing column with the mirror:

Fixing columns for Safety Light Curtains					
Reference - Column (with mirror)					
Fixing base column has to be ordered for each column.	Reference	For use with light curtains	Height (A) (mm)	Maximum protected height (mm)	Weight (kg)
	XUSZMF125	XUSL•E•••016...L•E•••091	1200	910 and 2 or 3 beams	5.8
	XUSZMF138	XUSL•E•••091...L•E•••106	1330	1060 and 4 beams	6.4
	XUSZMF172	XUSL•E•••106...L•E•••136	1700	1360	8.0
	XUSZMF202	XUSL•E•••136...L•E•••181	1970	1810	9.0

## Deflective Mirrors

Mirrors have to be firmly mounted and prevented from shocks. Observe safe mounting distances throughout the detection zone, including the distances to possible reflective surfaces.

For more information, refer to [Reflective Surface Interference, page 45](#).

This figure displays the mirror configurations:

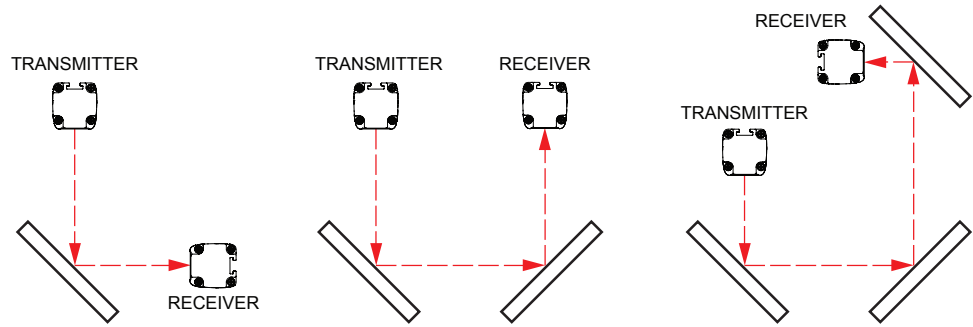

**NOTICE**

**UNINTENDED EQUIPMENT OPERATION**

The total nominal range between the transmitter and the receiver is reduced according to the number of mirrors. The sensing distance reduction coefficient 0.85 (-15% per mirror) has to be taken into account for each mirror used.

**Failure to follow these instructions can result in equipment damage.**

This figure describes the mirror for the Safety light curtain:

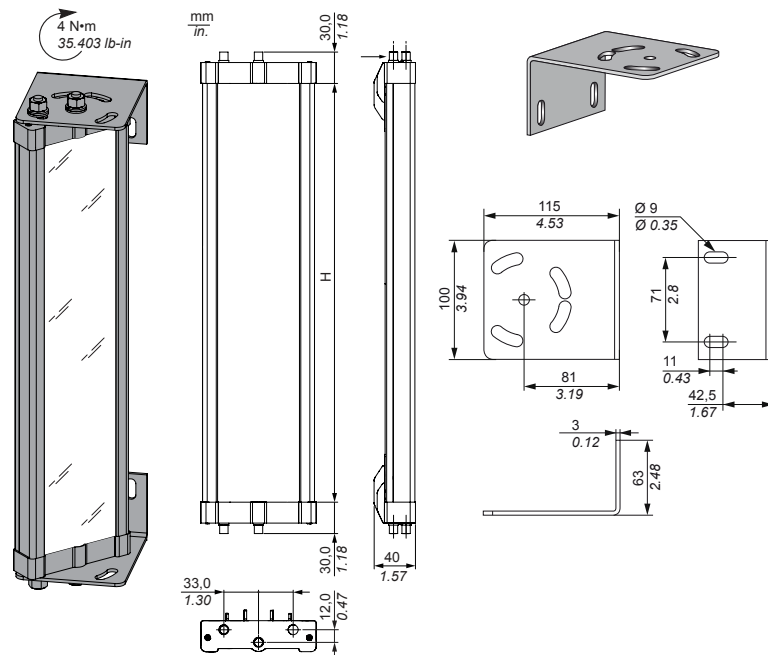

This table describes the mirrors used for safety light curtain:

Mirrors for Safety Light Curtain					
Glass mirrors (15%) <sup>1</sup>					
Description	Reference	For use with light curtains	Height H (mm)	Maximum protected height (mm)	Weight (kg)
	XUSZMD016	XUSL•E•••016	250	160	0.9
	XUSZMD031	XUSL•E•••026/ XUSL•E•••031	400	310	1.4
	XUSZMD046	XUSL•E•••046	540	460	1.8
	XUSZMD061	XUSL•E•••061 and 2 beams	715	610	2.4
	XUSZMD076	XUSL•E•••076	885	760	2.8
	XUSZMD091	XUSL•E•••091 and 3 beams	1060	910	3.3
	XUSZMD106	XUSL•E•••106 and 4 beams	1230	1060	3.8
	XUSZMD121	XUSL•E•••121	1400	1210	4.4
	XUSZMD136	XUSL•E•••136	1450	1360	4.5
	XUSZMD151	XUSL•E•••151	1600	1510	5.0
	XUSZMD166	XUSL•E•••166	1750	1660	5.5
	XUSZMD181	XUSL•E•••181	1900	1810	6.0

<sup>1</sup> Sensing distance reduction coefficient has to be taken into account for each mirror used.

## Protective Screen

The protective screen is a polycarbonate cover which protects the light curtain optical front screen in case of applications in harsh environments such as welding part projections or the presence of chemical products in workspace.

These figures display the various stages in the protective screen assembly:

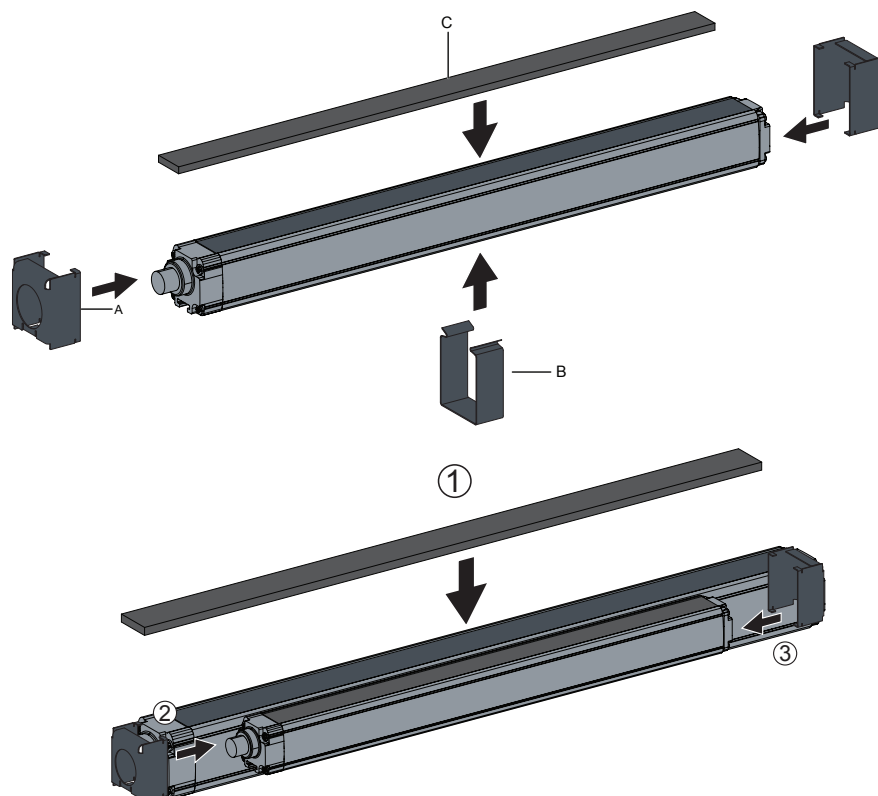

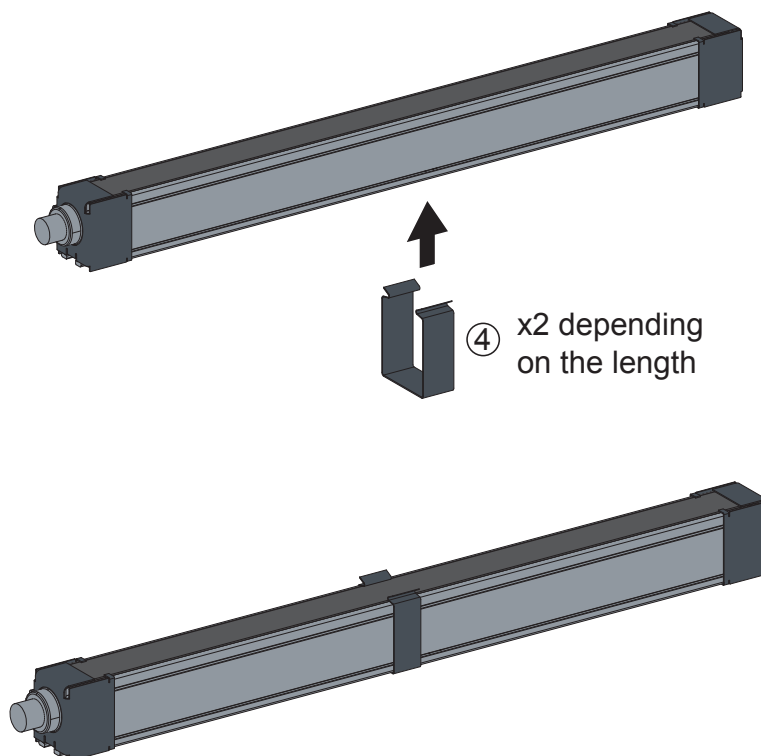

The protective screen can be easily replaced when it is worn-out, as a stainless steel clamping system is used to attach it.

This table describes the environmental characteristics and chemical resistance:

Protective Screen for Safety Light Curtains		
<b>Environmental Characteristics</b>		
Air temperature	For operation	-10...+55 °C (14...131 °F)
	For storage	-35...+70 °C (-31...158 °F)
Material	Screen	Polycarbonate
	Bracket	Stainless steel
Sensing distance reduction coefficient		0.97
<b>Environmental Chemicals</b>		
Chemical resistance	Aqueous solutions	Resistant
Detergents and cleaners		
Inorganic diluted acids		

This table describes the protective screen references:

Protective screen references				
Description	For use with light curtains	Length (mm)	Reference	Weight (kg)

Protective screen references				
Protective screen for safety light curtains	XUSL•E•••016	195	XUSZWPE015	0.08
	XUSL•E•••031	345	XUSZWPE030	0.14
	XUSL•E•••046	495	XUSZWPE045	0.20
	XUSL•E2BB051	635	XUSZWPE050	0.21
	XUSL•E•••061	645	XUSZWPE060	0.26
	XUSL•E•••076	795	XUSZWPE075	0.31
	XUSL•E3BB081	935	XUSZWPE080	0.33
	XUSL•E•••091	945	XUSZWPE090	0.38
	XUSL•E4BB091	1035	XUSZWPE091	0.41
	XUSL•E•••106	1095	XUSZWPE105	0.44
	XUSL•E•••121	1245	XUSZWPE120	0.50
	XUSL•E•••136	1395	XUSZWPE135	0.56
	XUSL•E•••151	1545	XUSZWPE150	0.62
	XUSL•E•••166	1695	XUSZWPE165	0.68
	XUSL•E•••181	1845	XUSZWPE180	0.74
Stainless steel clamps kit			XUSZWPEFC	0.15

Protective screen and stainless steel clamps kit must be ordered separately. Each reference of the protective screen includes four protective screens.

Each stainless steel clamp kit includes 4 end clamps and 4 lateral clamps.

Protective screen sets are not suitable with swiveling brackets XUSZBSS4.

## Laser Alignment Device

The laser pointer device (XUSZLPE) is an alignment help between the transmitter and the receiver. It is suitable for aligning transmitter and receiver operating over long range or in case defective mirrors are used.

This figure displays the laser alignment device:

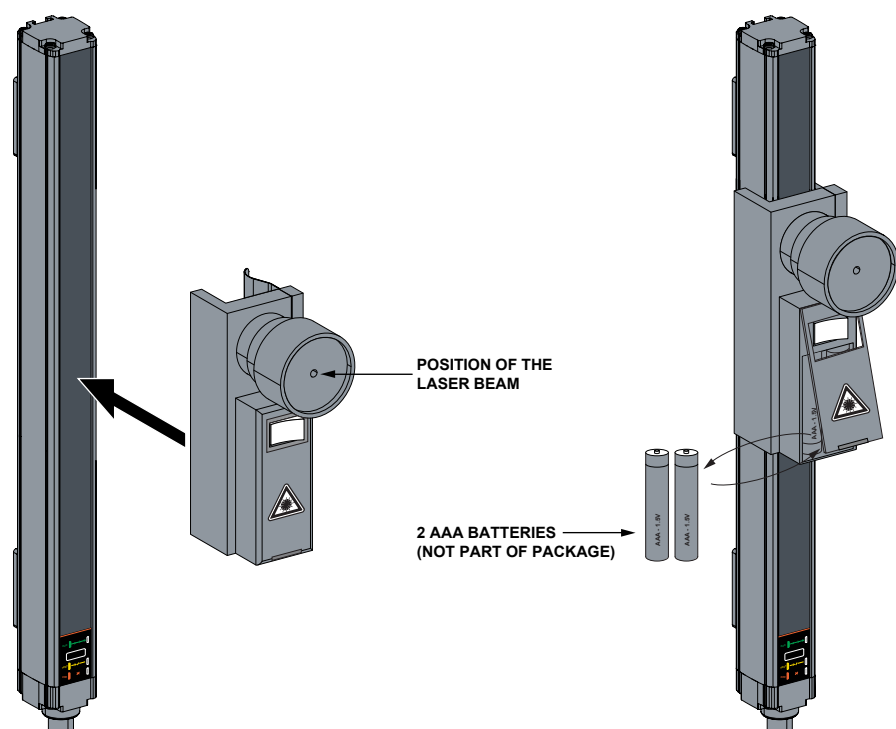

This figure describes the dimension of the laser alignment device:

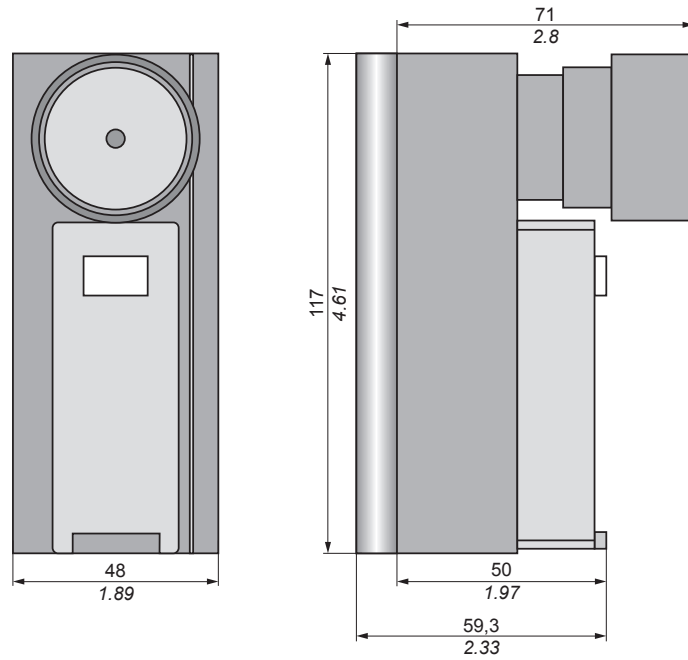

Weight = 0.8 kg / 1.76 lb.

When using XUSZLPE laser pointer for the alignment, start to point the middle of the safety light curtain for a first adjustment, then point the top and the bottom.

The laser pointer must properly sit flat against the optical window during the alignment.

The XUSZLPE emits a visible laser, Class 2 (according to IEC 60825-1) red light beam with an operating range up to 100 m.

<b>⚠ WARNING</b>
<p><b>UNINTENDED EQUIPMENT OPERATION</b></p> <ul style="list-style-type: none"> <li>• Never aim the laser source directly at others eyes or your own. Never look directly into the source.</li> <li>• Keep the laser ON only for the time which is strictly necessary for its professional use. Check that the device is OFF before putting it away.</li> <li>• If you have to keep the XUSZLPE inactive for sometime, take the batteries out and keep them separately.</li> <li>• Guard the device and do not let any unauthorized person access it.</li> </ul> <p><b>Failure to follow these instructions can result in death, serious injury, or equipment damage.</b></p>

For more details, check the European Standard EN 60825-1.

## Test Rod

The test rod is an opaque metallic cylindrical stick used to check no beams are bypassed due to the presence of reflecting surfaces.

This figure displays the test rod moving along the detection zone:

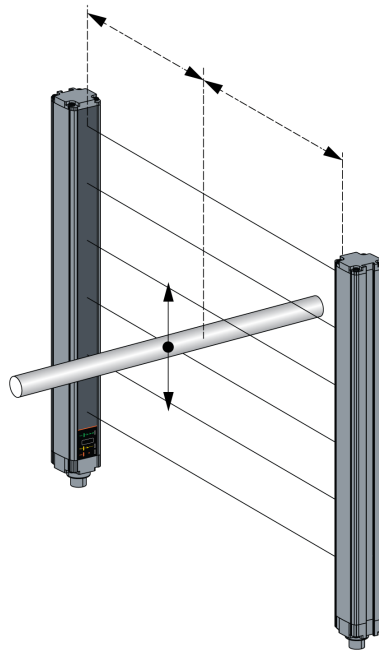

This table describes the references for the test rod:

Reference	Diameter (mm)	Weight (kg)
XUSZTR14	14	0.02
XUSZTR30	30	0.07

For more information about testing methods with the test rods, refer to [Test procedure, page 49](#).

The test rods are not supplied with the safety light curtains and must be ordered separately.

## Cables

This table describes the 5-pin transmitter cables of the safety light curtains:

Cables (Transmitter - 5 pins)	Description
XZCP1164L2	Connector M12 - Female - Straight - 5 poles - 2 m pre-wired
XZCP1164L5	Connector M12 - Female - Straight - 5 poles - 5 m pre-wired
XZCP1164L10	Connector M12 - Female - Straight - 5 poles - 10 m pre-wired
XZCP1164L15	Connector M12 - Female - Straight - 5 poles - 15 m pre-wired
XZCP1164L25	Connector M12 - Female - Straight - 5 poles - 25 m pre-wired
XZCP1264L2	Connector M12 - Female - 90° - 5 poles - 2 m pre-wired
XZCP1264L5	Connector M12 - Female - 90° - 5 poles - 5 m pre-wired
XZCP1264L10	Connector M12 - Female - 90° - 5 poles - 10 m pre-wired
XZCP1264L15	Connector M12 - Female - 90° - 5 poles - 15 m pre-wired
XZCP1264L25	Connector M12 - Female - 90° - 5 poles - 25 m pre-wired
XZCC12FDM50B	Connector M12 - Female - Straight - 5 poles with screw terminals- cable gland - Metal clamping ring
XZCC12FCM50B	Connector M12 - Female - 90° - 5 poles with screw terminals- cable gland - Metal clamping ring

This table describes the pin-wire connections for the M12, 5-Pin transmitter cable connectors:

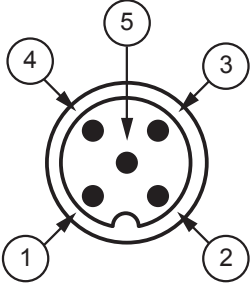
Connector	Pin Number	Wire Color	XUSL Description
	1	Brown	+24 Vdc
	2	Black/White	Configuration_0 or Primary/Secondary_A
	3	Blue	0 Vdc
	4	Black	Configuration_1 or Primary/Secondary_B
	5	Yellow/Green	FE

This table describes the 8-pin receiver cables of the safety light curtains:

Cables (Receiver - 8 pins)	Description
XZCP29P11L2	Connector M12 - Female - Straight - 8 poles - 2 m pre-wired
XZCP29P11L5	Connector M12 - Female - Straight - 8 poles - 5 m pre-wired
XZCP29P11L10	Connector M12 - Female - Straight - 8 poles - 10 m pre-wired
XZCP29P11L15	Connector M12 - Female - Straight - 8 poles - 15 m pre-wired
XZCP29P11L25	Connector M12 - Female - Straight - 8 poles - 25 m pre-wired
XZCP53P11L2	Connector M12 - Female - 90° - 8 poles - 2 m pre-wired
XZCP53P11L5	Connector M12 - Female - 90° - 8 poles - 5 m pre-wired
XZCP53P11L10	Connector M12 - Female - 90° - 8 poles - 10 m pre-wired
XZCP53P11L15	Connector M12 - Female - 90° - 8 poles - 15 m pre-wired
XZCP53P11L25	Connector M12 - Female - 90° - 8 poles - 25 m pre-wired
XZCC12FDM80B	Connector M12 - Female - Straight - 8 poles with screw terminals- cable gland - Metal clamping ring
XZCC12FCM80B	Connector M12 - Female - 90° - 8 poles with screw terminals- cable gland - Metal clamping ring

This table describes the pin-wire connections for the M12, 8-pin receiver connectors:

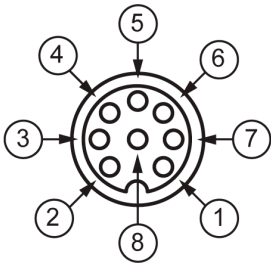
Connector	Pin Number	Wire Color	XUSL Description
	1	White	OSSD1
	2	Brown	+24 Vdc
	3	Green	OSSD2
	4	Yellow	Configuration_A
	5	Grey	K1_K2 Feedback/Restart
	6	Pink	Configuration_B
	7	Blue	0 Vdc
	8	Red	FE

This table describes the primary/secondary cables jumpers of the safety light curtains:

Cables (Primary/Secondary)	Description
XZCR1111064D03	2 straight M12 - Female/Female con. - 0.3 m - 5 poles
XZCR1111064D3	2 straight M12 - Female/Female con - 3 m - 5 poles
XZCR1111064D5	2 straight M12 - Female/Female con - 5 m - 5 poles
XZCR1111064D10	2 straight M12 - Female/Female con. - 10 m - 5 poles
XZCR1111064D25	2 straight M12 - Female/Female con - 25 m - 5 poles

# Appendices

## What's in This Part

Checkout and Test Procedures.....	106
-----------------------------------	-----

# Checkout and Test Procedures

## What's in This Chapter

Checkout Procedure .....	107
Test Procedure .....	109

### **⚠ WARNING**

#### **UNINTENDED EQUIPMENT OPERATION**

- The test frequency (for example daily testing) must be carried out depending on the risk analysis. This testing ensures that the light curtain, safety system, and the machine control system work together to stop the machine.
- To test the XU4M safety light curtains, use the proper-size test rod

**Failure to follow these instructions can result in death, serious injury, or equipment damage.**

# Checkout Procedure

## Procedure

A qualified personnel should perform the test procedure in the given table during initial XUSL safety light curtain system installation, according to the regular inspection program of the employer after any maintenance, adjustment, or modification of the XUSL safety light curtain system or the guarded machine.

Make a copy of the checkout procedure form, use the copy as the checkout log, and store it with the machine records. Be careful when you work around hazardous voltages present during this procedure.

**Machine Identification:**

**Date:**

Item		Condition	Comments
1	Verify that the guarded machine is compatible with the type of machine that is used with the XUSL system. Refer to <a href="#">Meeting Full Compliance, page 8</a> .	Pass	
		Fail	
2	Verify that the mounting distance of the XUSL system is greater than or equal to minimum safe distance from the hazard zone Refer to <a href="#">Safe Mounting Distance, page 33</a> .	Pass	
		Fail	
3	Determine that the access to the hazard zone which is not protected by an XUSL system is guarded by other means, such as gates, fencing, wire, or other approved methods. Verify that additional guarding devices are installed and operating correctly.	Pass	
		Fail	
4	Ensure that the operator does not stand between the XUSL system detection zone and the machine hazard zone. Verify that the light curtain can be reset from a position outside and within view of the hazardous machine area only.	Pass	
		Fail	
5	Verify that the XUSL is powered by a safety extra low voltage (SELV) or a protected extra low voltage (PELV). Refer to <a href="#">wiring instructions, page 61</a> .	Pass	
		Fail	
6	Verify that the external contactors conform the General Description for <a href="#">mirror contacts or force-guided contacts, page 22</a> .	Pass	
		Fail	
7	Verify that there is no reflective surfaces that might affect the proper operation of the XUSL. Refer to <a href="#">Reflective Surface Interference, page 45</a> .	Pass	
		Fail	
8	Verify that there are no interfering light sources that might affect the proper operation of the XUSL. Refer to <a href="#">Multiple System, page 50</a> .	Pass	
		Fail	
9	When used, verify that the MUTING/OVERRIDE signal lamp is correctly installed in a visible location by the operator.	Pass	
		Fail	
10	Inspect the electrical connections between the control system of the guarded machine and the XUSL system. Verify that they are connected correctly to the machine so that a stop signal from the XUSL system results in an immediate halt of the machine cycle.	Pass	
		Fail	
11	If the EDM monitoring feature is not used, proceed to step 12. To test the EDM feature: Verify that the feature has been correctly wired. Turn on the machine power. Cycle the machine. Disconnect the K1/K2 EDM feedback loop wire to test the EDM monitoring feature. Interrupt the detection zone, and the system should enter (and stay at) the start/restart state (yellow Led lit on the receiver) even if a restart command is operated.	Pass	
		Fail	
12	Record the test results in the machine log. Then perform the <a href="#">Test procedure, page 106</a> .	Results recorded	

**NOTE :** A periodic cleaning of the front face protection surfaces (polycarbonate optical window) of the two devices is recommended. Cleaning should be carried out with a soft damp cloth only. In particularly dusty environments, after cleaning the front face, it is advisable to spray it with an anti-static product.

Even a fine scratch on polycarbonate front surfaces can increase the width of the beam of the safety light curtain, thus compromising the effectiveness of detection in the presence of eventual reflective lateral surfaces.

<b>⚠ WARNING</b>
<b>UNINTENDED EQUIPMENT OPERATION</b>
<ul style="list-style-type: none"><li>• Do not use abrasive, corrosive, solvents, or alcohol that may damage the polycarbonate front surfaces.</li><li>• Do not use wiped or wool cloth to avoid electrostatically loading the polycarbonate front surfaces.</li><li>• Pay particular attention during the cleaning steps of the safety curtain front surface, particularly in environments where abrasive powders are present. (for example, cement plants, and so on)</li></ul>
<b>Failure to follow these instructions can result in death, serious injury, or equipment damage.</b>

**Comments:**

**Technician Signature:**

# Test Procedure

## Procedure

A qualified personnel should perform the test procedure in the given table during initial XUSL4E/XUSL2E light curtain system installation, according to the regular inspection program of the employer after any maintenance, adjustment, or modification of the XUSL4E/XUSL2E light curtain system or the guarded machine. This testing ensures that the light curtain, safety system, and the machine control system work together to stop the machine. If the test procedures are not followed, it could result in serious injury to personnel. To test the XUSL4E or XUSL2E safety light curtains, use the proper-size test rod.

Item		Condition	Comments
1	Switch off the machine to be guarded and connect power to the XUSL system.	Pass	
		Fail	
2	Visually inspect the machine to ensure that the hazard zone is accessible only through the XUSL detecting zone. If not, additional guarding, including mechanical barriers, may be required. Verify that the additional guarding devices and barriers are installed and operating properly.	Pass	
		Fail	
3	Verify that the mounting distance of the XUSL system is greater than or equal to the calculated minimum safe distance from the hazard zone.  For more information, refer to <a href="#">Safe Mounting Distance, page 33</a> .  Ensure that the operator does stand between the XUSL detection zone and the hazard zone.	Pass	
		Fail	
4	Check for signs of external damage to the XUSL system, the machine, and, the electrical cables and wiring.  If there is any damage, lock off the machine and report the damage to the supervisor.	Pass	
		Fail	
5	Interrupt the XUSL system detection zone with the applicable test object (test rod). Move the test object inside the perimeter (along the top, sides, and bottom) of the detection zone and, up and down through the center.  Verify that while the test rod object is in the perimeter, the red LED on the receiver is always ON.  In manual Start/Restart mode press and release the <b>Start</b> button before proceeding to step 6.	Pass	
		Fail	
6	Start the machine and then interrupt the detection zone with the test object which should stop the machine immediately. Do not insert the test object into the hazardous parts of the machine. Interrupt the detection zone with the test object when the machine is at rest.  Ensure that the machine does not start with the test object in the detection zone.	Pass	
		Fail	
7	Verify that the braking system is working properly. If the machine does not stop fast enough, adjust the braking system or increase the distance from the detection zone to the hazard zone.	Pass	
		Fail	
8	If the safety devices or the machine fail any of these tests, do not run the machine. Tag or lock out the machine immediately to prevent its use and notify the supervisor.		

**Comments:**

# Glossary

## A

### **ANSI :**

American National Standards Institute. The administrator and coordinator of the U.S. private sector standardization system.

## C

### **Category (Cat) :**

Describe the safety-related parts of control systems performance in relation to their ability to resist to failures and resulting behavior in case of failure. Five categories are defined depending on design architectures.

### **Control-reliable :**

The device, system, or interface shall be designed, constructed, and installed such that a single component failure within the device, interface, or system shall not prevent normal stopping action from taking place, but shall prevent a successive machine cycle (ANSI B11.191).

## D

### **Detection zone :**

The zone within which a specified test piece is detected by the XUSL4M safety light curtain system.

### **Diagnostic coverage (DC) :**

Efficiency measurement of self-tests conducted on a function. This is determined as the ratio of the rate of dangerous detected failures (per hour) and the rate of dangerous failures per hour.

## E

### **EDM/MPCE (External Device Monitoring/Machine Primary Control Element Monitoring) :**

A means by which the safety light curtain monitors the state of external control devices.

### **ESPE :**

Electro-sensitive protective equipment.

## M

### **Mean time to dangerous failures (MTTFd):**

Expectation of the mean time to dangerous failure.

## O

### **Off state :**

The state in which the output circuit is interrupted (open) and does not allow current to flow.

### **On state :**

The state in which the output circuit is complete (closed) and allows the flow of current.

### **OSHA :**

Occupational Safety and Health Administration. This is a U.S. government agency.

**Output Safety Switching Device (OSSD) :**

The component of the safety light curtain connected to the machine control system which, when the safety light curtain detection zone is interrupted, responds by going to Off state. This is also known as a safety output.

**P****Performance level (PL) :**

Ability of safety-related parts of control systems (SRP/CS) to perform a safety function in order to achieve the required risk reduction.

**Probability of Dangerous Failure per Hour :**

(PFH<sub>D</sub>) Average probability of dangerous failure per hour for high demand mode of operation.

**R****Resolution or Minimum Object Sensitivity (MOS) :**

The diameter (in millimeters) of the minimum-sized object that actuates the safety light curtain.

**Response time :**

Time taken by the protective device to transmit the signal to stop the main engine.

**S****Safety Integrated Level (SIL) :**

The failure mode evaluation based on the risk assessment in accordance with IEC 61508. Estimation of the required SIL is performed for each safety-related control function (SRCF) and represent the levels that the control-command must respect according to the known risk factors associated with the installation. Level 3 is the highest and Level 1 the lowest level.

**Safety Integrated Level Claim Limit (SILCL) :**

Maximum SIL that can be claimed for safety function of any subsystem.

**T****Test Road :**

An opaque cylindrical object used to verify the detection capability of the XUSL2E/XUSL4E system.

[www.telemecaniquesensors.com](http://www.telemecaniquesensors.com)

The information provided in this catalogue contains description of products sold by TMSS France, its subsidiaries and other affiliated companies ('Offer') with technical specifications and technical characteristics of the performance of the corresponding Offer.

The content of this document is subject to revision at any time without notice due to continued progress in methodology, design and manufacturing.

To the extent permitted by applicable law, no responsibility or liability is assumed by TMSS France, its subsidiaries and other affiliated companies for any type of damage arising out of or in connexion with (a) informational content of this catalogue not conforming with or exceeding the technical specifications, or (b) any error contained in this catalogue, or (c) any use, decision, act or omission made or taken on the basis of or in reliance on any information contained or referred to in this catalogue.

**NEITHER TMSS FRANCE, ITS SUBSIDIARIES, NOR ITS OTHER AFFILIATES, AS THE CASE MAYBE, MAKE NO WARRANTY OR REPRESENTATION OF ANY KIND, WHETHER EXPRESS OR IMPLIED, AS TO WHETHER THIS CATALOGUE OR ANY INFORMATION CONTAINED THEREIN SUCH AS PRODUCTS WILL MEET REQUIREMENTS, EXPECTATIONS OR PURPOSE OF ANY PERSON MAKING USE THEREOF.**

Telemecanique™ Sensors is a trademark of Schneider Electric Industries SAS used under license by TMSS France. Any other brands or trademarks referred to in this catalogue are property of TMSS France or, as the case may be, of its subsidiaries or other affiliated companies. All other brands are trademarks of their respective owners.

This catalogue and its content are protected under applicable copyright laws and provided for informative use only.

No part of this catalogue may be reproduced or transmitted in any form or by any means (electronic, mechanical, photocopying, recording, or otherwise), for any purpose, without the prior written permission of TMSS France. Copyright, intellectual, and all other proprietary rights in the content of this catalogue (including but not limited to audio, video, text, and photographs) rests with TMSS France, its subsidiaries, and other affiliated companies or its licensors. All rights in such content not expressly granted herein are reserved. No rights of any kind are licensed or assigned or shall otherwise pass to persons accessing this information.

As standards, specifications and design change from time to time, please ask for confirmation of the information given in this publication.

©2025, TMSS France, All Rights Reserved.

**TMSS France SAS**

Share capital: 366 931 214 €  
Tour Eqho, 2 avenue Gambetta  
92400 Courbevoie – France  
908 125 255 RCS Nanterre

October 2025 - V1.0

TESEUG000307EN