

XCSR

Miniature Contactless RFID Safety Switches

User Manual

Original instructions



Legal Information

The information provided in this guide contains description of products sold by TMSS France, its subsidiaries and other affiliated companies ('Offer') with technical specifications and technical characteristics of the performance of the corresponding Offer.

The content of this document is subject to revision at any time without notice due to continued progress in methodology, design and manufacturing.

To the extent permitted by applicable law, no responsibility or liability is assumed by TMSS France, its subsidiaries and other affiliated companies for any type of damage arising out of or in connexion with (a) informational content of this guide not conforming with or exceeding the technical specifications, or (b) any error contained in this guide, or (c) any use, decision, act or omission made or taken on the basis of or in reliance on any information contained or referred to in this guide.

NEITHER TMSS FRANCE, ITS SUBSIDIARIES, NOR ITS OTHER AFFILIATES, AS THE CASE MAYBE, MAKE NO WARRANTY OR REPRESENTATION OF ANY KIND, WHETHER EXPRESS OR IMPLIED, AS TO WHETHER THIS GUIDE OR ANY INFORMATION CONTAINED THEREIN SUCH AS PRODUCTS WILL MEET REQUIREMENTS, EXPECTATIONS OR PURPOSE OF ANY PERSON MAKING USE THEREOF.

Telemecanique™ Sensors is a trademark of Schneider Electric Industries SAS used under license by TMSS France. Any other brands or trademarks referred to in this guide are property of TMSS France or, as the case may be, of its subsidiaries or other affiliated companies. All other brands are trademarks of their respective owners.

This guide and its content are protected under applicable copyright laws and provided for informative use only.

No part of this guide may be reproduced or transmitted in any form or by any means (electronic, mechanical, photocopying, recording, or otherwise), for any purpose, without the prior written permission of TMSS France. Copyright, intellectual, and all other proprietary rights in the content of this guide (including but not limited to audio, video, text, and photographs) rests with TMSS France, its subsidiaries, and other affiliated companies or its licensors. All rights in such content not expressly granted herein are reserved. No rights of any kind are licensed or assigned or shall otherwise pass to persons accessing this information.

Table of Contents

About the Book	4
General	5
Safety Requirements	5
Product Description.....	7
General Information	7
XCSRМ RFID Safety Switches General Description	7
How a XCSRМ RFID Safety Switches Works?	8
Operating Zones ($S_{ao} - S_{ar}$)	9
Definition of Characteristic Times	10
System Response Time (Process Safety Time)	11
Risk Assessment	12
System Components	14
System Components Identification	14
XCSRМ Features.....	16
XCSRМ RFID Safety Switches Functions	17
Operating Modes	17
External Device Monitoring (EDM) or Machine Primary Control Element (MPCE) Monitoring.....	19
Operating states and Diagnostic in one Smart LED	20
XCSRМ Single Models for Point-to-Point Connections	21
XCSRМ Advanced Models for Standalone (EDM function).....	23
XCSRМ Advanced Models for Series Connection.....	25
Daisy-Chain Diagnostic by Pulsed State Output	28
Installation, Wiring, and Diagnostic.....	30
Installation.....	31
Parts List.....	31
Mounting the XCSRМ RFID Safety Switch.....	32
Wiring.....	36
Electrical Connections	37
Diagnostic by HMI.....	50
New Actuator Pairing During Maintenance	51
Diagnostic of Series Connection by Pulsed State Output	54
Technical Characteristics	55
XCSRМ RFID Safety Switch Specifications	55
Safety Related Data.....	58
Dimensions	58
Accessories	60
Glossary.....	63

About the Book

Document Scope

This manual describes the features, installation, wiring, usage, and troubleshooting of the XCSRМ RFID Safety Switches.

Validity Note

The technical characteristics of the devices described in this manual also appear online.

To access this information online:

Step	Action
1	Go to www.telemecaniquesensors.com .
2	In the Search box, type the model number of a product or the name of a product range. Do not include blank spaces in the model number/product range.
3	If more than one model number appears in the Products search results, click on the model number that interests you.
4	To save or print a data sheet as a .pdf file, click Download product datasheet .

The characteristics that are described in the present document should be the same as those characteristics that appear online. In line with our policy of constant improvement, we may revise content over time to improve clarity and accuracy. If you see a difference between the document and online information, use the online information as your reference.

QR Code

A QR code including the Telemecanique Sensors web address is present on the XCSRМ RFID Safety Switches marking. Technical documents are available in various languages in this website.



Related Documents

Title of documentation	Reference number
XCSRМ RFID Safety Switches - Quick Start Guide	BQT4922101

You can download these technical publications and other technical information from our website at www.telemecaniquesensors.com

User Comments

We welcome your comments about this document. You can reach us through the customer support page on your local Telemecanique Sensors website.

General

Overview

This part provides detailed information about the safety requirements and product description.

Safety Requirements

Precautions

 WARNING
UNINTENDED EQUIPMENT OPERATION <ul style="list-style-type: none">• This equipment must only be installed and serviced by qualified personnel.• Read, understand, and follow the compliance below before installing the XCSRМ RFID Safety Switches. Failure to follow these instructions can result in death, serious injury, or equipment damage.

Meeting Full Compliance

The compliance of a machine and the XCSRМ RFID Safety Switches with safety regulations, depends on the proper application, installation, maintenance, and operation of the XCSRМ RFID Safety Switches. These are responsibilities of the purchaser, installer, and employer.

The employer is responsible for selecting and training the personnel necessary to properly install, operate, and maintain the machine and its safeguarding systems. The XCSRМ RFID Safety Switches must only be installed, checked, and maintained by a qualified person. A qualified person is defined as “a person or persons who, by possession of a recognized degree or certificate of professional training, or who, by extensive knowledge, training and experience, has successfully demonstrated the ability to solve problems relating to the subject matter and work” (ANSI B30.2).

- To use the XCSRМ RFID Safety Switches, the given requirements must be met:
- The guarded machine must be able to stop anywhere in its cycle.
- The guarded machine must not present metallic chips in the vicinity of the XCSRМ RFID Safety Switches.
- The guarded machine must have a consistent stopping time and adequate control mechanisms.
- All applicable governmental and local rules, codes, and regulations must be satisfied. This is the user and employer responsibility.
- All safety-related machine control elements must be designed so that an alarm in the control logic or the control circuit breakdown does not lead to a XCSRМ RFID Safety Switches failure.
- Perform a test of the XCSRМ RFID Safety Switches during installation and after maintenance or adjustment. As well as in case of any modification of the machine controls, tooling, machine or of the RFID guarding system.
- The proper functioning of the XCSRМ RFID Safety Switches and its operating line must be checked on a regular basis based on the level of security required by the application (for example, number of operations, level of environmental pollution, ...).
- Perform only the test and diagnostic procedures outlined in this manual.

- Follow all procedures in this manual for proper operation of the XCSRМ RFID Safety Switches.
- All safety-related machine control circuit elements, including pneumatic, electric, or hydraulic controls must be control-reliable.

The enforcement of these requirements is beyond the control of TMSS France. The employer has the sole responsibility to follow the preceding requirements and any other procedures, conditions, and requirements specific to the machinery.

Product Support

For more information about products and services in your country, visit www.telemecaniquesensors.com.

Product Description

Overview

This chapter describes the general information, XCSRМ RFID Safety Switches functions, and system components.

General Information

XCSRМ RFID Safety Switches General Description

Overview

The XCSRМ RFID Safety Switches are used where personnel protection is required. The basic applications are for monitoring the position of movable safety guards to prevent hazardous situations from occurring when the safety guard is opened. Such as, for example:

- Robotic work cells
- Electronic manufacturing machine
- Roll handling equipments
- Machine tools
- Food and beverage equipments
- Packaging machines
- General assembly lines

How a XCSRМ RFID Safety Switches Works?

General Description

A XCSRМ RFID Safety Switches is a contactless system that consists of a microprocessor-controlled switch (also called "sensor" or "reader") and a transponder, called after an "actuator".

The switch is to be mounted on the fixed part of the safety guard, and the actuator on the mobile part.

There is no contact between the actuator and the switch, a radio-frequency technology is used for the communication.

The switch and the actuator are paired in factory. During the manufacturing, the switch loads into the actuator with which it is sold, a unique code. This saved digital code is the unique "key" accepted by the paired switch.

When the actuator enters the radio frequency field generated by the switch (by closing a guard door for example), the switch detects the actuator and reads the data in the actuator memory.

If the actuator code demanded by the switch is correct, the switch changes its two redundant safety outputs (OSSDs) to the **ON** state, indicating that the safety guard is closed and thus allowing the machine operation. For more details, refer to [XCSRМ RFID Safety Switches Functions, page 17](#).

When the actuator goes outside the field generated by the switch (by opening a guard door for example) the switch changes its two redundant safety outputs (OSSDs) to the **OFF** state in order to stop the machine, indicating that the safety guard is opened.

By the use of a unique coding, RFID technology is robust against tampering (Type 4 - High level of coding - according to ISO 14119).

A high-coded actuator cannot be reprogrammed during run-time. If for any reason, like a tampering attempt, the switch does not receive from an actuator the only expected code saved in factory, the communication with the actuator is rejected by the switch. The switch then enters in Error mode and changes its safety outputs to the **OFF** state. A new power-up is then required. XCSRМ RFID Safety Switches is designed to be compliant with the safety requirements maximum to PLe - Cat 4 (EN ISO 13849-1), SIL3 (IEC 61508) and SILCL3 (IEC 62061).

This illustration presents the XCSRМ RFID Safety Switches:

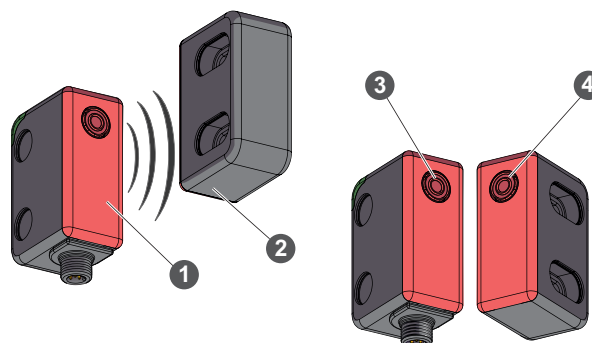

- 1 Switch
- 2 Actuator
- 3 Switch dialog area
- 4 Actuator dialog area

Operating Zones ($S_{ao} - S_{ar}$)

General Description

When paired actuator and switch are both operating:

- S_{ao} (Assured operating sensing distance) is the distance from the sensing face within which the presence of the specified target is correctly detected under all specified environmental conditions (for example: operating temperature, material of the mounting support) and manufacturing tolerances.
- S_{ar} (Assured release sensing distance) is the distance from the sensing face beyond which the absence of the specified target is correctly detected under all specified environmental conditions (e.g operating temperature, material of the mounting support) and manufacturing tolerances.
- The value of S_{ao} is the switching distance below which the **ON** state is defined with an absolute certainty (the blue area in the drawing hereunder = OSSDs **ON**)
- The value of S_{ar} is the switching distance beyond which the **OFF** state is defined with an absolute certainty (the red area in the drawing hereunder = OSSDs **OFF**)
- S_r is the real switch-on sensing distance.

The gray zone represents the “transient state”. Inside the gray area, the commutation points are thus not guaranteed (dispersions zone).

S_{ao} and S_{ar} values depend on the approach directions and the misalignment between the actuator and the switch (refer to [Mounting and Operating Distances, page 32](#)).

The switch and the actuator parts must be mounted in accordance with the given S_{ao} and S_{ar} values to ensure a switch **ON** and a switch **OFF** respectively in the blue ($<S_{ao}$) and red ($>S_{ar}$) areas.

This diagram describes the operating zones:

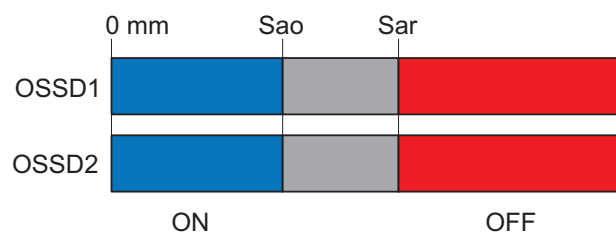

Guaranteed sensing distances for XCSRМ RFID Safety Switches are given in face to face configuration and without misalignment between the actuator and the switch:

- $S_{ao} = 10 \text{ mm (0.39 in)}$
- $S_{ar} = 25 \text{ mm (0.98 in)}$
- **Hysteresis:** $H_r < 2.4 \text{ mm (0.09 in)}$ ($20 \% \times S_r$), $S_r = 12 \text{ mm (0.47 in)}$

Refer to [face to face mounting configuration, page 35](#).

A slight delay between the switching of the two OSSDs exists and is defined as the “OSSDs Delay Time (T_{DT})” [Definition of Characteristic Times, page 10](#).

Definition of Characteristic Times

Response Time (T_t)

Time between the actuator is entering the operating zone, and the switching of the OSSDs to the **ON** state:

Typical Response time $T_t \leq 250$ ms,

This time applies for only one switch. In daisy-chain configuration, each additional switch increases this time by 12 ms typically (< 20 ms maximum).

Risk Time (T_r)

Time between the actuator is leaving the operating zone, and the switching of the OSSDs to the **OFF** state. $T_r < 55$ ms. This time applies for only one switch. In daisy-chain configuration, each additional switch increases this time by 12 ms.

First-up Time (T_{ON})

After a power-up, the system is performing self-tests for checking its integrity. The first-up time is the delay, from power-up, after which the system is ready for operation. Switch-on delay 10 s typical (15 s maximum).

OSSDs Delay Time (T_{DT})

Defines the time difference between the OSSDs for switching to the OFF state. $T_{DT} < 500$ ms, $T_{DT} \text{ max} < 510$ ms, $T_{DT} \text{ min} < 490$ ms.

OSSDs Pulse Time (T_{PT})

This time is the width of the periodic pulses generated on each OSSD to perform the monitoring of the safety outputs (short-circuit detection for example). This pulse duration must be compatible with the downstream equipment connected to the OSSDs (safety control unit for example). $T_{PT} = 0.1$ ms, $T_{PT} \text{ max} = 0.12$ ms, $T_{PT} \text{ min} = 0.08$ ms ; duty cycle maximum 1100 ms, typical 1000 ms, min 900 ms.

System Response Time (Process Safety Time)

General Description

According to EN ISO 13855, the total response time (T) corresponding to the overall system stopping performance is calculated by the given formula:

$$T = t_1 + t_2$$

Where:

t_1 = Response time of the protection system (in second). It is the total time between the actuation of the safeguard and the switching to the OFF state of its output components. This time corresponds to the "Risk Time" (T_r)

t_2 = Stopping time of the machine (in seconds): maximum time required to terminate the hazardous machine function after the output signal from the safeguard achieves the OFF-state. This information is supplied by the machine manufacturer. The response time of the control and the output systems of the machine is included in t_2 .

WARNING

UNINTENDED OPERATION ACTION

Mount far enough away the XCSRМ RFID Safety Switch from the operations hazard to fully accommodate the stopping time.

Failure to follow these instructions can result in death, serious injury, or equipment damage.

When using a safety control unit like safety relays or controllers, the response time of the safety control unit must be added to the overall system stopping time.

Risk Assessment

General Description

Risk assessment and risk reduction are **iterative processes** described in EN ISO 12100, IEC 61508 & IEC 62061 (SIL and SILCL), and EN ISO 13849-1 (PL). There are various techniques for risk assessment, and not one of it can be considered as the right way to perform risk assessment. The standard specifies some general principles but does not specify exactly what has to be done in each case.

For safety-related data, refer to [Safety Related Data, page 58](#).

This flowchart describes the risk assessment process:

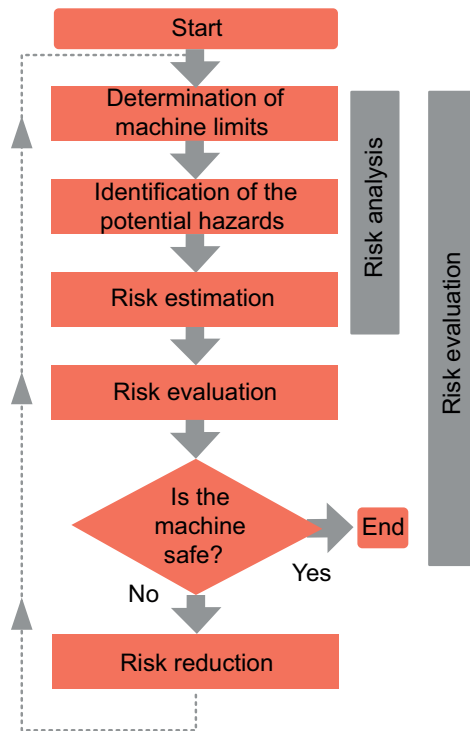

Essential steps for risk assessment are the following:

- Define tolerable risk level.
- Identify hazards.
- Analyze hazards.
- Determine whether the risks are below an acceptable level.
- Define protection measures if risks are above a tolerable level.
- Check whether protection measures taken lead to an effective risk reduction (Iterative process).

This figure describes the elements of risk to take into account for the risk estimation:

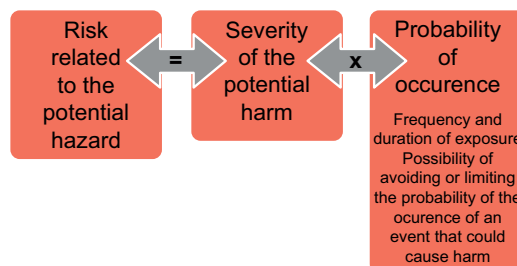

It is the responsibility of the user or integrator to check whether the use of the XCSRМ RFID Safety Switch is consistent with the application risk assessment.

⚠ WARNING**UNINTENDED EQUIPMENT OPERATION**

Perform a risk assessment to choose the right product for your application.

Failure to follow these instructions can result in death, serious injury, or equipment damage.

Reference Standards

The following table describes the main reference standards:

Standard	Risk assessment	Description
EN ISO 12100 : 2010	Risk assessment and risk reduction	Safety of machinery.General principles for design. Risk assessment and risk reduction.
Standard	Safety level	Description
EN ISO 13849-1 : 2015	Performance level (PL)	Safety-related part of control system.General principles for design.
	Category (Cat)	
IEC 61508 : 2010	Safety integrity level (SIL)	Functional safety of electrical/electronic/programmable electronic safety-related systems.
IEC 62061 : 2021	Safety integrity level claim limit (SILCL)	Safety of machinery.Functional safety of safety-related electrical, electronic, and programmable electronic control systems.
Standard	Type-B standards	Description
ISO 14119 : 2013	Safeguards (interlocking devices)	Safety of machinery.Interlocking devices associated with guards.Principles for design and selection.
EN/IEC 60947-5-2 : 2019	Low-voltage switchgear and controlgear	Control circuit devices and switching elements. Proximity switches.
EN/IEC 60947-5-3 : 2019	Low-voltage switchgear and controlgear	Control circuit devices and switching elements. Requirements for proximity devices with defined behavior under fault found conditions (PDDB).

System Components

Overview

This section describes the system components and the main features of the XCSRМ RFID Safety Switches.

System Components Identification

General Description

This figure displays the system components:

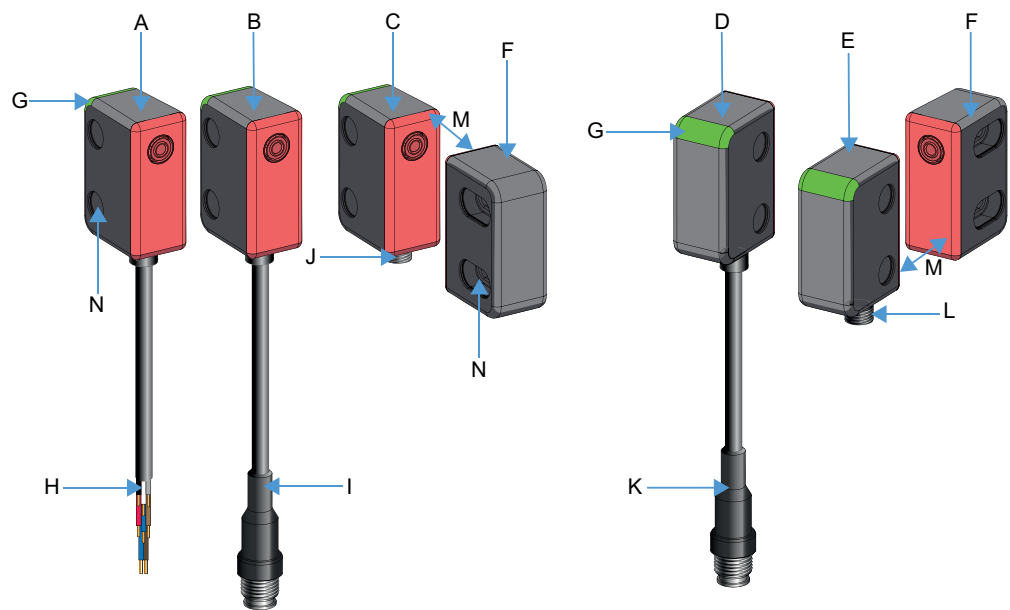

This table describes the system components:

Item	Description	Item	Description
A	XCSRМ•0L2/L5/L10: Single model by cable	H	2 m (6.56 ft) / 5 m (16.40 ft) / 10 m (32.80 ft) cable with 5 wires
B	XCSRМ•0L01M12: Single model by pre-wired connector	I	100 mm (3.93 inch) cable with M12 - 5 pins male connector
C	XCSRМ•0L2: Single model by connector	J	M12 - 5 pins male connector
D	XCSRМ•3L01M12: Advanced model by pre-wired connector	K	100 mm (3.93 inch) cable with M12 - 8 pins male connector
E	XCSRМ•3M12: Advanced model by connector	L	M12 - 8 pins male connector
F	Actuator	M	Dialog area between switch and actuator
G	Smart LED	N	Blanking plugs

Product Symbolization

This table describes the meaning of the references:

Contactless RFID Safety Switch	X	C	S					
Sensor								
RFID	R							
Sensor Shape								
Miniature Design		M						
Pairing Capability								
One Unique pairing - No new actuator pairing - High coded according to ISO14119						1		
3 pairing - 3 times of new actuator pairing - High coded according to ISO14119						3		
Unlimited Pairing - Unlimited times of new actuator pairing - High coded according to ISO14119						U		
Generic code - Accept any generic actuator without pairing - Low coded according to ISO14119						L		
Application								
Single						0		
Advanced (Daisy-Chain + EDM)						3		
Wiring								
Cable							L	
								02
								05
								10
Connector							M	
								12
Pigtail							L	
								01
								M12

XCSRМ Features

Features This table describes the main standard features of XCSRМ RFID Safety Switches:

Features	XCSRМ•0•••	XCSRМ•3•••
	Single	Advanced
Two PNP safety outputs (OSSDs)	✓	✓
Automatic start/restart without EDM	✓	✓
Monitored manual start without EDM	–	✓
Automatic start/restart with EDM	–	✓
Manual start/restart with EDM	–	✓
Series connection (daisy-chain)	–	✓
Point-to-point connection to a safety control unit	✓	✓
State output to Non Safety control unit (PLC)	✓	✓
Diagnostic output to Non Safety control unit (PLC)	–	✓
Miniature design mounting hole spacing 22mm	✓	✓
LED indicators for status and diagnosis	✓	✓
2m, 5m, 10m cables with 5 wires	✓	–
Pre-wired M12 male connector, page 60 (accessories to be ordered separately)	✓	✓
M12 male connector, page 60 (accessories to be ordered separately)	✓	✓
References for unique code - Unique pairing	XCSRМ10•••	XCSRМ13•••
References for unique code - Unlimited new actuator pairings possible	-	XCSRМУ3•••
References for unique code - 3 times actuator pairings possible	XCSRМ30•••	-
Reference for code - new generic actuator can dialog directly to switch without pairing *	XCSRМL0•••	XCSRМL3•••
✓ indicates feature availability in the corresponding XCSRМ RFID Safety Switch model. * According to ISO14119, unique code products are classified as high coded level rather than general code of low coded level.		

XCSRМ RFID Safety Switches Functions

Overview

This section describes the various functions of XCSRМ RFID Safety Switch.

Operating Modes

Introduction

The operating mode determines the start-up and operating behavior of the XCSRМ RFID Safety Switch.

Automatic Start

In this mode, the system enters the **Run** state after startup without operator intervention, as long as the paired actuator is in the switch detection zone.

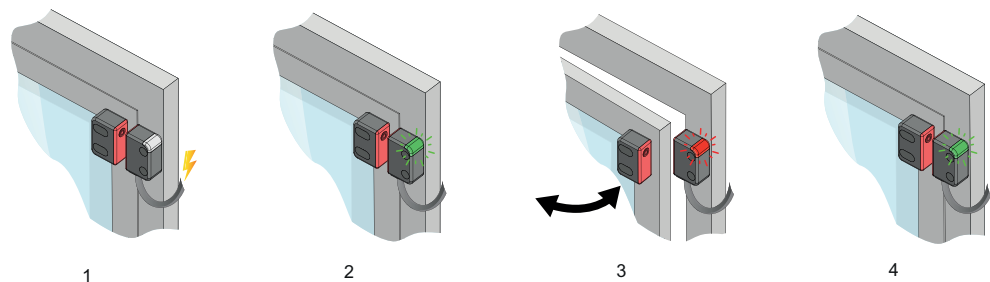

1. When the XCSRМ RFID Safety Switch is powered up, it enters the initialization phase during which its safety outputs are **OFF**.

2. If no faults are detected and the safety guard is closed, it enters the **Run State**, [page 20](#) after 5 seconds maximum (refer to T_{ON} [First-up Time](#), [page 10](#)) and the two safety outputs switch to **ON** state.

3. In this state, when the actuator leaves the operating zone (safety guard opening), the XCSRМ RFID Safety Switch changes from **Run** state to **Stop State**, [page 20](#) (the two safety outputs switch to **OFF** state), and remains in the **Stop** state until the paired actuator enters again the detection zone (without any fault detected).

4. The XCSRМ RFID Safety Switch then automatically changes from **Stop** state to **Run** state and the two safety outputs switch to **ON** state.

Automatic Start is available on XCSRМ•0... Single models and XCSRМ•3... Advanced models

The manual Start/Restart is required in most safety applications.

⚠ WARNING

UNINTENDED EQUIPMENT OPERATION

Check that this automatic start mode is compatible with risk assessment performed for the application.

Failure to follow these instructions can result in death, serious injury, or equipment damage.

Manual Start/Restart

When the XCSRМ RFID Safety Switch is powered up, it enters the initialization phase during which its safety outputs are **OFF**. If no faults are detected after the first-up time, it enters the Start/Restart state. To enter the **Run** state and switch the OSSDs to **ON**, the paired actuator must be in the switch detection zone, no faults detected, and the operator must press and release ("monitored start") the **Start** button in the machine. Then, if the XCSRМ RFID Safety Switch leaves the detection zone when it is in **Run** state, the XCSRМ RFID Safety Switch changes to Stop state and the safety outputs change from **ON** to **OFF** state.

If the paired actuator enters the detection zone again (and no faults are detected), the safety outputs stay at the **OFF** state until the **Start** push button is actuated in the machine.

WARNING

UNINTENDED EQUIPMENT OPERATION

- Follow the requirements concerning start/restart operating modes defined in ISO 12100: "Requirements for interlocking guards with a start function (control guards)" section.
- The Restart command must be installed outside the hazardous area in such way that the whole working and hazardous areas are observable. You must not access the Start/Restart command inside the hazardous area.

Failure to follow these instructions can result in death, serious injury, or equipment damage.

NOTE:

- For "monitored manual Start/Restart", the command is effective after the operator has pressed and released the **Start** button, which means a transition sequence 0 Vdc → 24 Vdc → 0 Vdc on the start command. The minimum duration of this sequence must be between 200 ms and 5 s. Beyond the 5 s, the release action on the command will not activate the XCSRМ RFID Safety Switches. The operator will have to repeat the start/restart sequence and release the command before 5 s.
- The "monitored manual Start/Restart" is available exclusively on XCSRМ•3••• Advanced models.
- For Single and Daisy-Chain XCSRМ RFID Safety Switch models, refer to the safety control unit operating instructions.

External Device Monitoring (EDM) or Machine Primary Control Element (MPCE) Monitoring

General Description

EDM monitoring is an important safety function.

The EDM monitors the interface between XCSRМ RFID Safety Switch and the guarded machine to:

- Confirm that the external devices such as switching devices like contactors are responding correctly to the XCSRМ safety outputs.
- Detect any inconsistency between the two external devices (that is, control relays or contactors) which could prevent a stop signal from reaching the machine primary control elements (for example, power contactors or electrovalve relays).

The EDM controls the external contactors KM1/KM2 connected to the two OSSDs. To achieve this, normally closed contacts of the external contactors are monitored. To perform this function, the contactors KM1/KM2 must have:

- Normally closed mirror contact, according to IEC 60947-4-1 (Annex F) for power contactors.
- Linked contacts (or force-guided contacts), according to IEC 60947-5-1 (Annex L) or EN 50205 for auxiliary contactors or control relays.

RFID Safety Switch XCSRМ•3••• Advanced models have built-in EDM function. For Daisy-Chain and Single models, refer to the operating instructions of your safety control unit (e.g safety relay or safety controller).

To manage the EDM function, refer to [Electrical Connections, page 37](#).

Operating states and Diagnostic in one Smart LED

This figure describes the diagnostic LED of the XCSRМ switch:

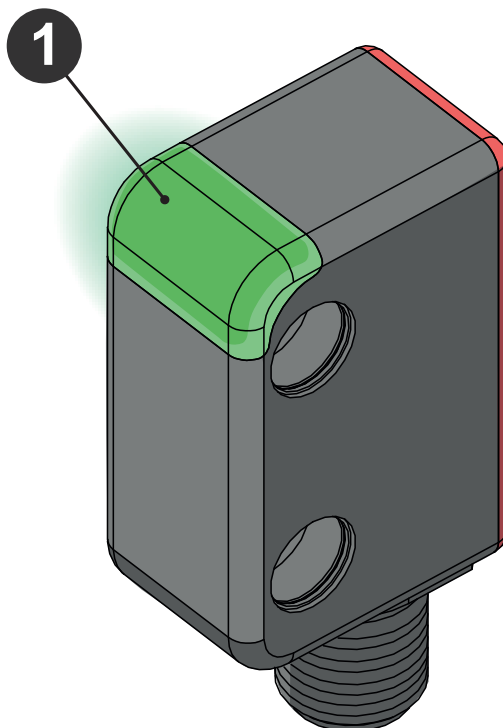

The XCSRМ Safety RFID switch provides a highly visible multi-colored LED (1) to notify status in real time.

This HMI function includes following functions:

- Indicate safety status of RFID switch
- Indicate configuration mode when RFID switch starts up
- Indicate error message for diagnostics
- Guide pairing process

For more details about the meaning of the LED behavior, see [Diagnostic by HMI, page 50](#).

XCSRM Single Models for Point-to-Point Connections

General Description

XCSRM•0... (5-pin) references are suitable for monitoring multiple safeguards by point-to-point connections to a safety control unit (safety controller or safety PLC for example).

Refer to [Connection Schematics](#), page 45.

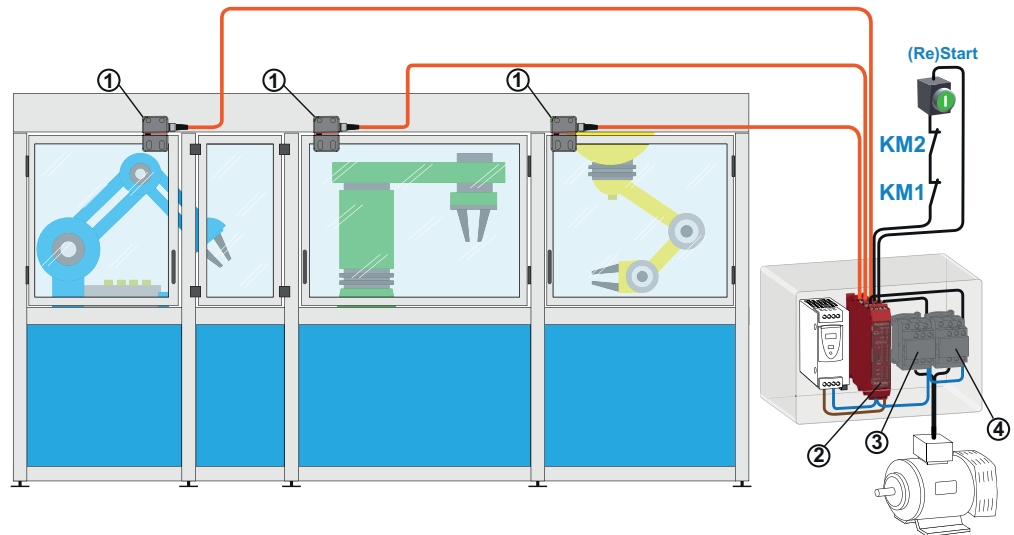

- 1 XCSRM•0L01M12: XCSRM RFID Safety Switch single model
- 2 Safety controller
- 3 KM1: contactor 1 - OSSD1
- 4 KM2: contactor 2 - OSSD2

The association of the XCSRM switches is, in this case, made by software at the safety control unit level.

⚠ WARNING

UNINTENDED EQUIPMENT OPERATION

The KM1 and KM2 contactors must have [force-guided contacts](#), page 19.

Failure to follow these instructions can result in death, serious injury, or equipment damage.

Features and Requirements

Single XCSRМ•0... models have the given features and requirements:

- 2 OSSDs.
- The association with a safety control unit (safety controller for example) is mandatory.

⚠ WARNING
<p>UNINTENDED EQUIPMENT OPERATION</p> <p>The safety inputs of the safety control unit must be suitable to XCSR OSSDs pulsed signals specified in XCSRМ RFID Safety Switches specification - Characteristics Time, page 56.</p> <p>Failure to follow these instructions can result in death, serious injury, or equipment damage.</p>

Single models XCSRМ•0... are compliant with the following safety standards:

- Maximum to SIL3 (IEC 61508) SILCL3 (IEC 62061), and PLe- Cat.4 (EN ISO 13849-1)
- The overall safety integrity level of the system must consider the configuration of XCSRМ•0... switches connected but also the reliability data of the signal processing unit and the output system.

It is the aim of the risk analysis to determine whether the use of single models XCSRМ•0... are compatible with the expected safety integrity level of the entire system. Please refer to [Risk Assessment, page 12](#).

It is the responsibility of the user or integrator to check whether the use of the XCSRМ RFID Safety Switch is consistent with the application risk assessment.

⚠ WARNING
<p>UNINTENDED EQUIPMENT OPERATION</p> <p>Perform a risk assessment to choose the right product for your application.</p> <p>Failure to follow these instructions can result in death, serious injury, or equipment damage.</p>

XCSRМ Advanced Models for Standalone (EDM function)

General Description

XCSRМ•3••• (8 pin) Advanced models are designed to be used as standalone products, when associated with contactors having mechanically linked contacts (force-guided) connected to the OSSDs that is, without any safety relay, controller, or PLC. In standalone operation, the two OSSDs are connected directly to the contactors. This connection is made through a pre-wired 8 pins M12 connector.

Refer to Connection Schematics (see [Manual Start/Restart with EDM](#), page 40).

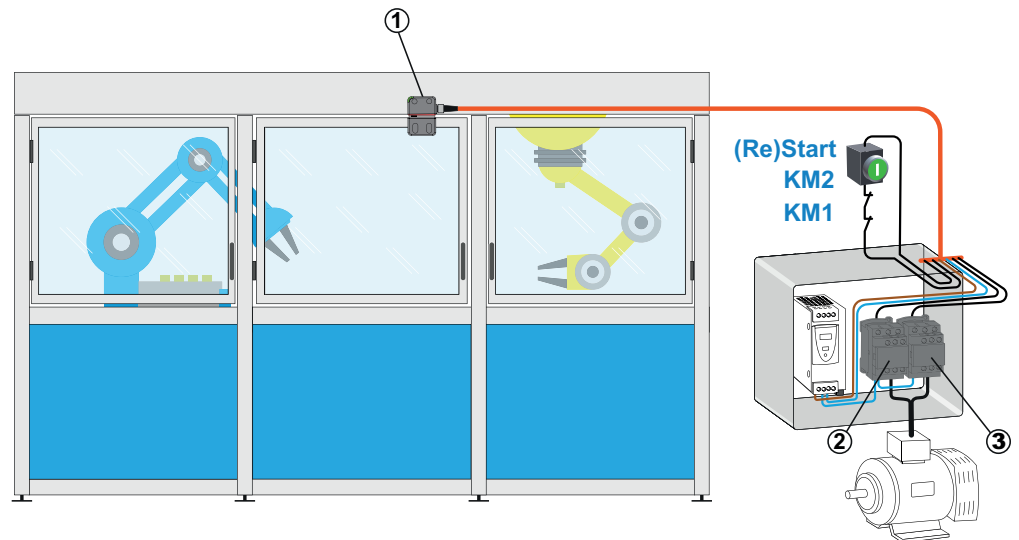

- 1 XCSRМ•3M12: XCSRМ RFID Safety Switch advanced model
- 2 KM1: contactor 1 - OSSD1
- 3 KM2: contactor 2 - OSSD2

⚠ WARNING
UNINTENDED EQUIPMENT OPERATION
The KM1 and KM2 contactors must have force-guided contacts (see External Device Monitoring (EDM) or Machine Primary Control Element (MPCE) Monitoring , page 19).
Failure to follow these instructions can result in death, serious injury, or equipment damage.

NOTICE
INOPERABLE EQUIPMENT
Use of arc suppressors for KM1 & KM2 is recommended.
Failure to follow these instructions can result in equipment damage.

Features and Requirements

The XCSR RFID Safety Switch Advanced models have the given features and requirements:

- 2 OSSDs
- External Device Monitoring (EDM)
- Start feature (selected by wiring):
 - Manual Start/Restart
 - Automatic Start/Restart

XCSRМ•3••• Advanced models are compliant with the following safety standards maximum to SIL3 (IEC 61508) SILCL3 (IEC 62061), and PLe- Cat.4 (EN ISO 13849-1).

It is the aim of the risk analysis to determine whether the use of XCSRМ•3••• Advanced models are compatible with the expected safety integrity level of the entire system.

It is the responsibility of the user or integrator to check whether the use of the XCSRМ RFID Safety Switch is consistent with the application risk assessment.

 **WARNING**

UNINTENDED EQUIPMENT OPERATION

Perform a risk assessment to choose the right product for your application.

Failure to follow these instructions can result in death, serious injury, or equipment damage.

XCSRМ Advanced Models for Series Connection

General Description

XCSRМ•3••• Advanced models of XCSRМ RFID Safety Switches can be connected in series. The daisy-chain function allows multiple safety guards to be connected in series.

The switches can be easily connected with "Y" connector with M12-8 pins jumper cables and M12 pins jumper cables.

A simple connection between the XCSRМ switches can thus be made by using Y connectors and male/female jumper cables (see [cable references, page 61](#)).

Refer to [connection schematics, page 38](#).

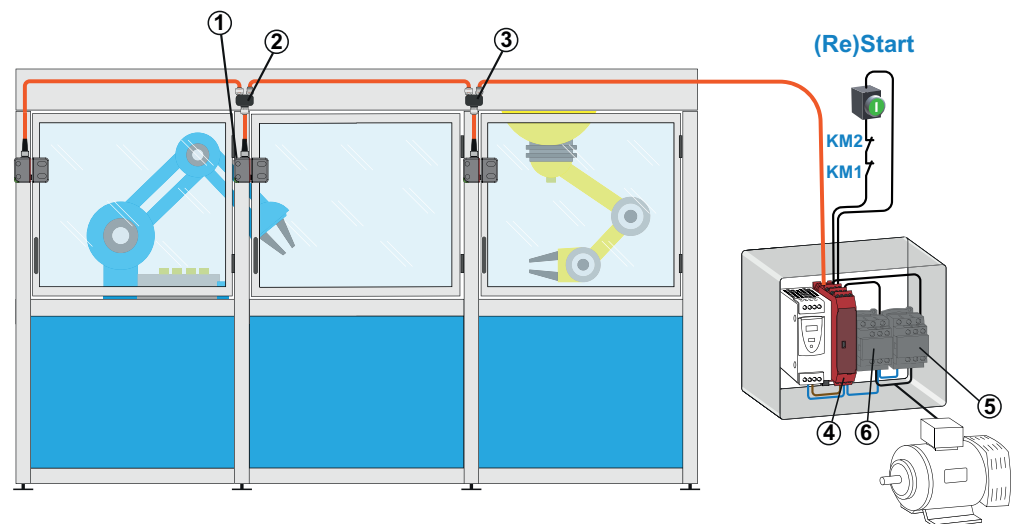

- 1 XCSRМ•3L01M12: XCSRМ RFID Safety switch Advanced model
- 2 XCSRZY1: Y connector to chain 1st and 2nd RFID switch
- 3 XCSRZY2: Y connectors to chain from 2nd to last RFID switch
- 4 XPSUAK•••: Safety relay
- 5 KM1: contactor 1 - OSSD1
- 6 KM2: contactor 2 - OSSD2

⚠ WARNING

UNINTENDED EQUIPMENT OPERATION

The KM1 and KM2 contactors must have [force-guided contacts, page 19](#).

Failure to follow these instructions can result in death, serious injury, or equipment damage.

Features and Requirements

XCSRМ•3••• Advanced models have the given features and requirements:

- 2 OSSDs.
- Up to 16 XCSRМ•3••• can be connected in series.
- Maximum cable length for serial connection is 260 m (853.01 ft) from 1st switch to 16th.

- The association with a safety control unit (safety relay or controller for example) is mandatory.

⚠ WARNING
UNINTENDED EQUIPMENT OPERATION
The safety inputs of the safety control unit must be suitable to XCSR OSSDs pulsed signals specified in XCSR RFID Safety Switch specification - Characteristics Time, page 56 .
Failure to follow these instructions can result in death, serious injury, or equipment damage.

XCSR•3•••Advanced models are compliant with the following safety standards:

- maximum to SIL3 (IEC 61508) SILCL3 (IEC 62061), and PLe- Cat.4 (EN ISO 13849-1)
- The overall safety integrity level of the system must consider the number of XCSR•3••• switches connected in series but also the reliability data of the signal processing unit and the output system.



According to EN ISO 13849-1 and/or EN IEC 62061, the PFH_D corresponding to a SIL3 integrity level of a safety function must be within the following limits:

$$10^{-7} \geq PFH_D \geq 10^{-8}$$

PFH_D = average probability of dangerous failure per hour for high demand or continuous mode of operation

The contribution to the total PFH_D of the switches, the signal processing unit, and the output system depends on the reliability data of the devices used in the application.

An example of PFH_D contribution of an entire safety function is given below:

XCSR••	XPSUAF1•••TE	Redundant contactor:
PFHD = 2.62x10 ⁻⁹	PFHD = 1.13x10 ⁻⁹	PFHD = 24.7x10 ⁻⁹
		
Switches	Logic Treatment	Pre-actuators/Actuators

Theoretical maximum number of switches connectable in series

In this example, the maximum PFH_D allowed for the series connection is:

$$[PFH_{Dmax}] \text{ switches} = 1 \times 10^{-7} - 1.13 \times 10^{-9} - 24.7 \times 10^{-9} = 74.17 \times 10^{-9}$$

The PFH_D of one XCSR RFID Safety Switch is 2.62x10⁻⁹, it means that the **theoretical** maximum number of XCSR RFID Safety Switch that could be connected in series, without impacting the overall safety level (SIL3-PLe) would be $N_{max} = 74.17 \times 10^{-9} / 2.62 \times 10^{-9} = 28$

Thus, the maximum number of chainable switches will be more limited by electrical constraints

Practical maximum number of switches connectable in series

In practice, by considering a realistic number of switches which could be connected in series as well as electrical limitations, **the maximum number of XCSRМ RFID Safety Switch that can be connected in series has been limited to 16.**

NOTE: The maximum number of switches that can be connected in series depends on different factors:

- The overall safety integrity level expected for the application.
- The cable length between each XCSRМ switch,
- The output current,
- The input voltage,
- The wire cross section (see [Electrical Connections, page 37](#)).

It is the responsibility of the user or integrator to check whether the use of the XCSRМ RFID Safety Switch is consistent with the application risk assessment.

 **WARNING**

UNINTENDED EQUIPMENT OPERATION

Perform a risk assessment to choose the right product for your application.

Failure to follow these instructions can result in death, serious injury, or equipment damage.

Daisy-Chain Diagnostic by Pulsed State Output

Status Output Transmission Protocol

XCSRМ•3... Advanced models provide a system status output for diagnostics without using dedicated module. This pulsed state output signal is a 24 Vdc square waveform that represents the status of the Safety RFID switches in daisy-chain.

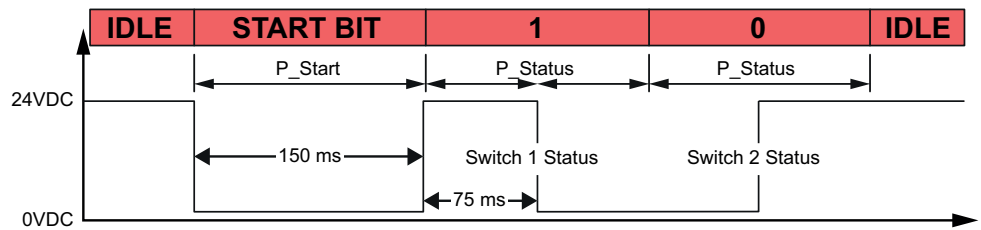

NOTE: The timing requirements for data transmission are not critical to the safety of the device, as “Status” is not a safety output.

Pulsed Output Example in Daisy-chain

The pulsed output containing XCSRМ•3... Advanced models’s Status is shown in following figures for three sensors connected in daisy-chain. The first and second switches are in safe status with the actuator inside the Sao range. The third switch has its actuator out of the Sar distance; therefore, it is in un-safe status. The output waveform from start to S3 status changes to low level (0 VDC) and S3 to S2 status changes to high level (24 VDC), so that PLC can identify which door is open in daisy-chain.

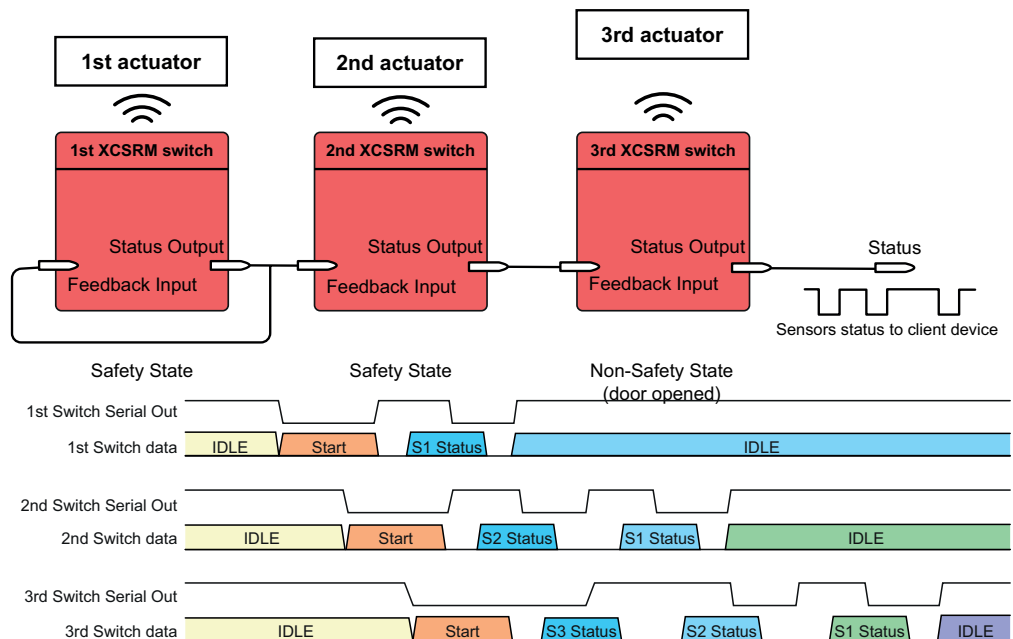

New Actuator Pairing

General Description

For every model (Advanced and single), three different pairing modes are available:

- **XCSR1M1••••** "unique pairing" models: Unique Code, digital code saved in factory. New actuator pairing is impossible.
In case of actuator damage, the actuator and the switch must be both replaced.

- **XCSR3M3••••** "3 times pairing enabled" models: Unique Code, digital code saved in factory. 3 times of actuator pairings are possible.

In case of actuator damage, a new blank actuator can be paired by the switch within unlimited new actuator pairings. Blank actuators are available as spare parts (XCSRK1BU).

A new actuator pairing removes definitely the previous code saved in the switch. The previous actuator is thus no longer usable.

Please follow pairing procedure in [New Actuator Pairing During Maintenance, page 51](#)

NOTE: An actuator is paired only one single time and can never be reprogrammed.

- **XCSR1MU••••** "unlimited re-pairing enabled" models: Unique Code, digital code saved in factory. Unlimited times of actuator pairings are possible.
In case of actuator damage, a new blank actuator can be paired by the switch within unlimited new actuator pairings. Blank actuators are available as spare parts (XCSRK1BU).

A new actuator pairing removes definitely the previous code saved in the switch. The previous actuator is thus no longer usable.

Please follow pairing procedure in [New Actuator Pairing During Maintenance, page 51](#)

NOTE : An actuator is paired only one single time and can never be reprogrammed.

XCSR1ML•••• "Generic code enabled" models: **Coded, digital code saved in factory. Generic actuator can be recognized by generic coded switch without pairing process.**

The generic actuator are available as spare parts (XCSRK1BL)

Installation, Wiring, and Diagnostic

Overview

This section provides information about installation, wiring, and startup.

WARNING

UNINTENDED EQUIPMENT OPERATION

- Read the information in this section completely before starting the [installation procedures, page 32](#).
- The XCSRМ RFID Safety Switch must be installed, checked, and maintained by qualified personnel as defined in the [Meeting Full Compliance, page 5](#).
- The user must be familiar with the installation requirements, system controls, and features before using the XCSRМ RFID Safety Switch.
- Check the correct operation of the XCSRМ RFID Safety Switch at power-up phases and before each shift.
- Check the presence of metallic chips (even small) in the vicinity of the XCSRМ RFID Safety Switch can modify the sensing distance.

Failure to follow these instructions can result in death, serious injury, or equipment damage.

Installation

Overview

This chapter describes the installation of the XCSRМ RFID Safety Switches.

Parts List

Parts

This figure displays the different parts of the XCSRМ RFID Safety Switches:

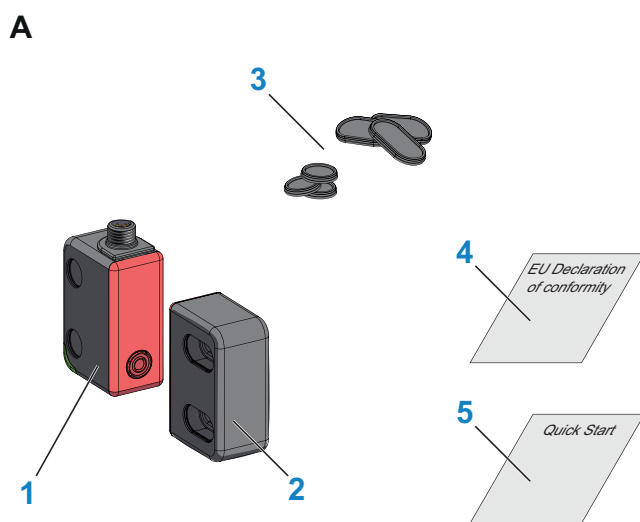

A. The XCSRМ RFID Safety Switches package includes:

1. XCSRМ Switch with connection (paired in factory).
2. XCSRМ Actuator (paired in factory).
3. 6 x Blanking plugs.
4. EU Declaration of conformity.
5. Quick start guide.

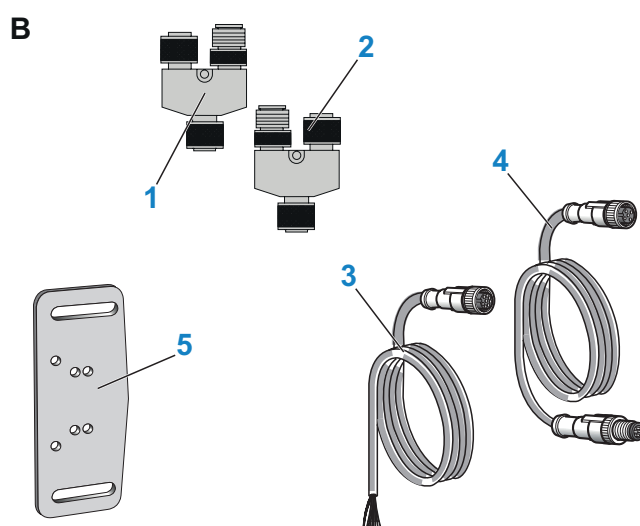

B. Accessories (to be ordered separately):

1. M12 8-8-5 pins Y connector for 1st switch in Daisy-Chain.
2. M12 8-5-5 pins Y connector for the 2nd to 16th switches in Daisy-Chain.
3. Switch connection cable: female M12 5 or 8 pins pre-wired.
4. Switch interconnections (daisy-chain): male/ female M12 8 pins.
5. Mounting bracket.

For more details, see [Accessories](#), page 60.

Mounting the XCSRМ RFID Safety Switch

Overview

The operating distances depend on the approach direction.

⚠ WARNING
UNINTENDED EQUIPMENT OPERATION
Before mounting the XCSRМ RFID Safety Switch, refer to this section.
Failure to follow these instructions can result in death, serious injury, or equipment damage.

Mounting

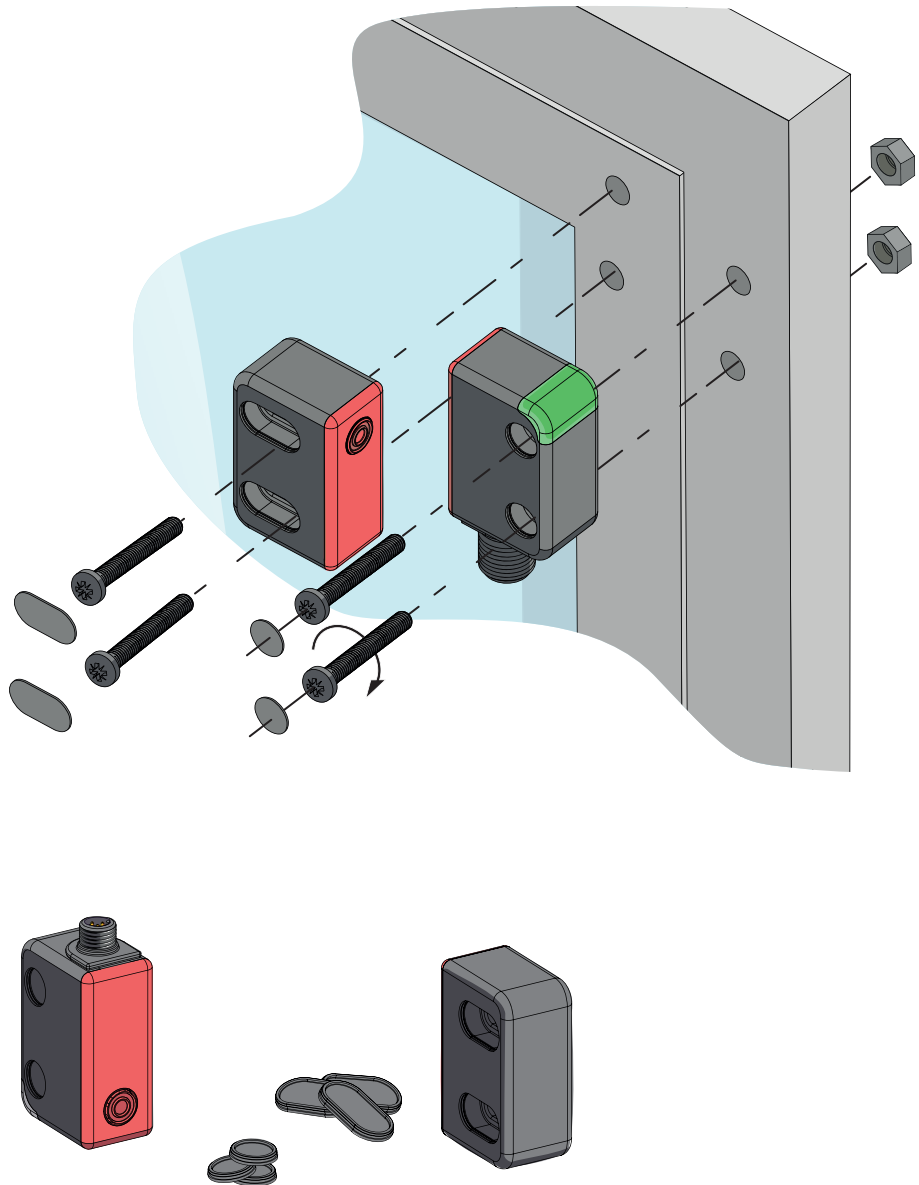

NOTE: To prevent unauthorized removal of the switch and/or the actuator, one-way screws are available as [Accessories, page 60](#).

Area of Electromagnetic Interference

The side lobes of the sensor field may influence the transponder behavior, depending on the actuator position

To avoid influence of the side lobes, observe the specified distances between sensor and actuator:

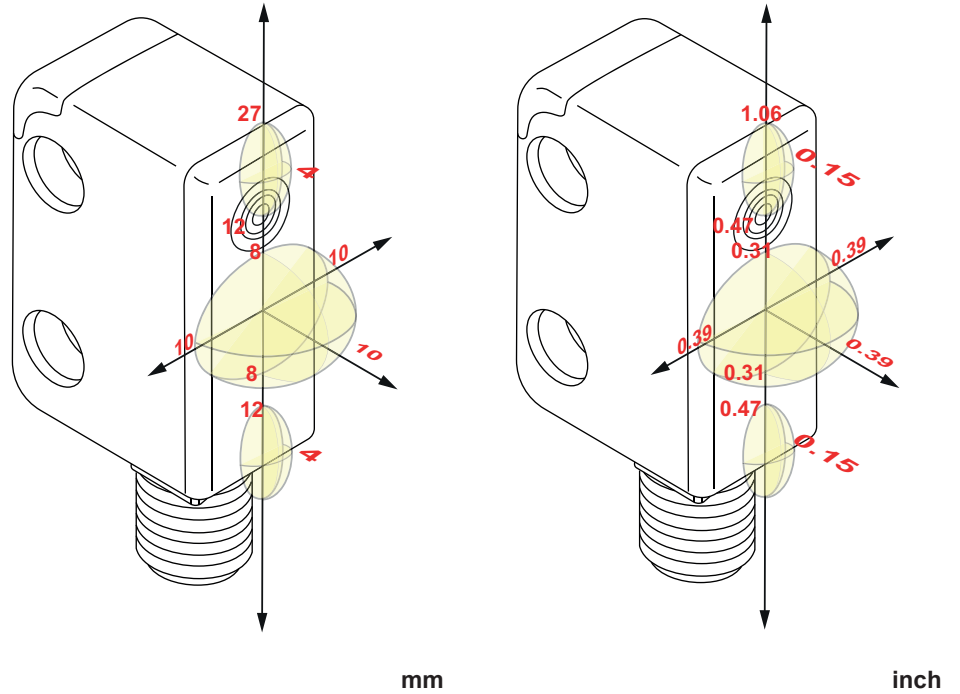

Multiple Systems

In case of applications requiring multiple switches which are mounted in close proximity, a minimum distance between switches must be respected to avoid mutual interferences:

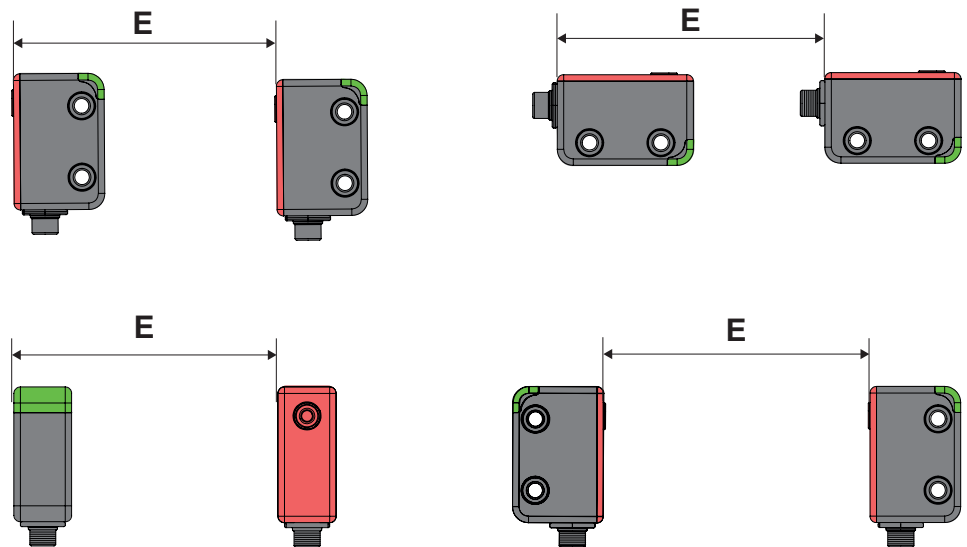

$$E_{\min.} = 150 \text{ mm} / 5.91 \text{ in.}$$

Functional Directions

Different allowed approach directions and associated detection curves are given below.

Typical switch-on and switch-off values are given for information only, and with a non-magnetic material support for the actuator and the switch. These typical values may vary depending on the support materials used.

WARNING

UNINTENDED EQUIPMENT OPERATION

Mount and use the XCSRМ RFID Safety Switch with respect to the assured sensing distances S_{ao} and S_{ar} . When the guard is closed, the maximum distance between the actuator and the switch must be S_{ao} .

Failure to follow these instructions can result in death, serious injury, or equipment damage.

When the guard is being opened and up to S_{ar} , the protected machinery shall not present any risk of danger.

At every power-up phase, an automatic tuning between the actuator and the switch is performed. The aim of this automatic tuning is to reduce the environmental effects on the sensing distances (for example, material of the mounting support, room temperature).

WARNING

UNINTENDED EQUIPMENT OPERATION

Install the actuator and switch in their definitive operational conditions before operating the power-up.

Failure to follow these instructions can result in death, serious injury, or equipment damage.

Functional Direction FD1 (“Face to Face” Mounting): CORRECT CONFIGURATION

In these configurations, actuator and switch sensing areas are “face to face”:

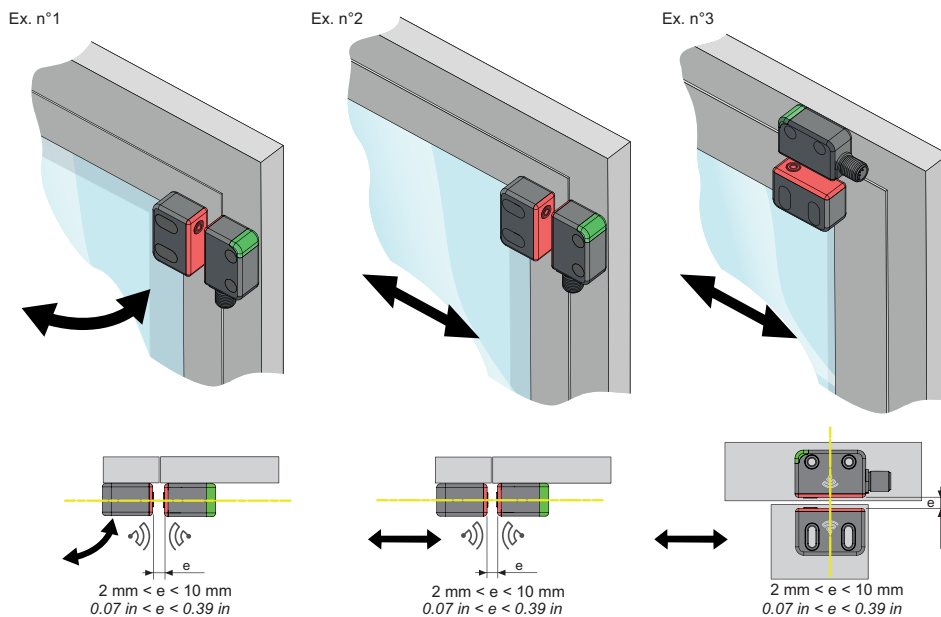

e Recommended minimum mounting distance between actuator and switch.

NOTICE
<p>INOPERABLE EQUIPMENT</p> <p>Do not use the XCSRМ switch as a mechanical stop for the mobile part of the safeguard.</p> <p>Failure to follow these instructions can result equipment damage.</p>

Wrong mounting example:

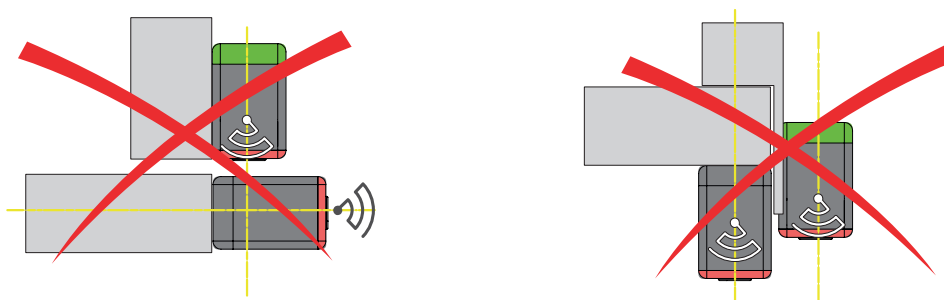

Detection Curves for “Face to Face” Mounting: CORRECT CONFIGURATION

The following figure shows the activation distances in function of the three axis (X, Y, Z):

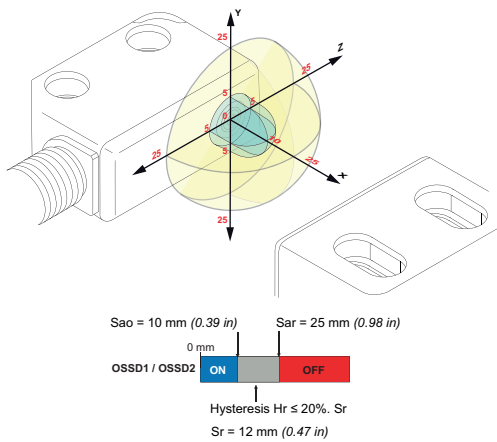

- X axis: Sao = 10 mm (0.39 in) ; Sar = 25 mm (0.95 in)
- Y axis: Sao = 5 mm (0.19 in) ; Sar = 25 mm (0.95 in)
- Z axis: Sao = 5 mm (0.19 in) ; Sar = 25 mm (0.95 in)

Sr = Real switch-ON sensing distance

Sao = assured operating distance

Sar = assured release distance.

Sao, Sar, Hr values above are given without misalignment between the switch and the actuator (X=Y=Z=0).

1 mm = 0.039 in.

Wiring

Overview

⚠️ ⚠️ DANGER

HAZARD OF ELECTRIC SHOCK

- The XCSRМ RFID Safety Switches must be powered by a dedicated safety extra low voltage (SELV) or a protected extra low voltage (PELV).
- The external power supply must comply with EN 60204-1.

Failure to follow these instructions will result in death or serious injury.

The XCSRМ RFID Safety Switches operate directly from a 24 Vdc power supply.

⚠️ DANGER

UNINTENDED EQUIPMENT OPERATION

- The XCSRМ RFID Safety Switches must be connected using both safety outputs.
- The OSSD1 and OSSD2 output signals must not be connected between each other.
- The two loads must be individually connected between the corresponding safety output terminal and the 0 Vdc: OSSD1 → LOAD1 → 0 Vdc and OSSD2 → LOAD2 → 0 Vdc.
- You must use the correct voltage suppressors on the outputs when connecting high inductive loads to OSSDs.
- The 0 Vdc must be common to all system components.

Failure to follow these instructions will result in death or serious injury.

A single safety output, if it fails, may not stop the machine.

The switch provides a voltage of 24 Vdc on BOTH safety outputs.

Electrical Connections

Single Model (XCSRM0000)

This table describes the pin-wire connections for the M12, 5-pin connector of single models:

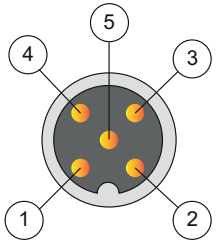
M12, 5-pin (XCSRML0000, XCSRM3000, XCSRM1000)				
Connector	Pin number	Connection Designation	Description	Wire color
	1	+ 24 Vdc	24 Vdc power supply	BN Brown
	2	OSSD1	Safety output OSSD channel 1	WH White
	3	0 Vdc	0 Vdc power supply	BU Blue
	4	OSSD2	Safety output OSSD channel 2	BK Black
	5	Status	Sensor status output (non safety PNP)	GY Grey

Automatic Start/Restart Connection

When the sensor is configured in "Automatic" the device behavior is the following:

- A safety gate opening (sensor/actuator distance > Sar) will deactivate the OSSD outputs.
- At the safety gate closure (sensor/actuator distance < Sao) will reactivate the OSSD outputs.

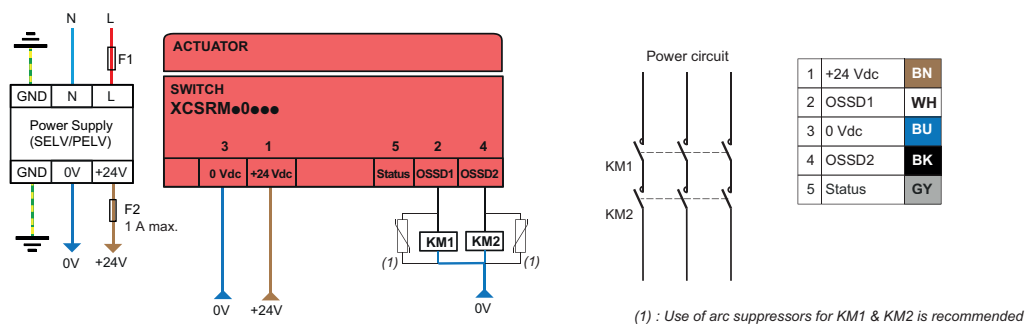

BN Brown **BU** Blue **GY** Grey
WH White **BK** Black

Refer to [Cable References XZCP11V12L00](#) or [XZCP12V12L00](#), page 61.

Maximum Cable Lengths point to point connection (max. 100 m / 328 ft)

Depending on the length of the links of single connections, it is mandatory to ensure that the auxiliary power supply is 24 Vdc, as shown in the following table:

Connection Type	Length	Connecting cable cross section	Power supply Voltage	Power supply Auxiliary	Max. Load	Note
Single sensor	≤ 50 m (≤ 164 ft)	0.25 mm ²	24 Vdc	None	0.5 A	-
Single sensor	≤ 100 m (≤ 328 ft)	0.25 mm ²	24 Vdc	None	0.25 A	-
Single sensor	50 m < length < 100 m (164 ft < length < 328 ft)	0.25 mm ²	24 Vdc	Yes	0.5 A	Auxiliary power supply cable required (single model only)
Single sensor	≤ 30 m (≤ 98 ft)	0.14 mm ²	24 Vdc	None	0.5 A	-
Single sensor	≤ 60 m (≤ 196 ft)	0.14 mm ²	24 Vdc	None	0.25 A	-
Single sensor	30 m < length < 80 m (98 ft < length < 262 ft)	0.14 mm ²	24 Vdc	Yes	0.5 A	Auxiliary power supply cable required (single model only)

Special connection for the auxiliary power supply

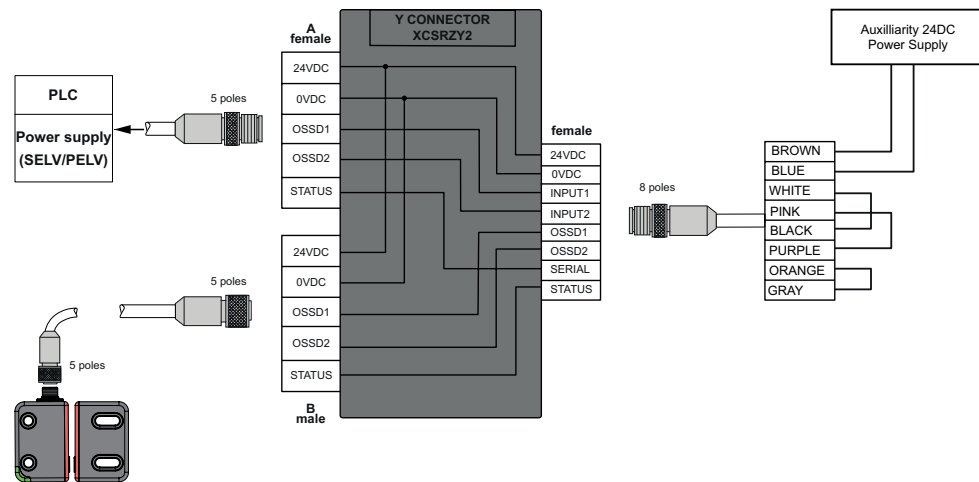

Advanced Model (XCSRM•3•••)

This table describes the pin-wire connections for the M12, 8-pin connectors of Advanced models:

M12, 8-pin (XCSRML3••••, XCSRMU3••••, XCSRM13••••)				
Connector	Pin number	Connection Designation	Description	Wire color
	1	+24 Vdc	24 Vdc power supply	BN Brown
	2	Input1	Safety input for daisy-chain channel 1	WH White
	3	0 Vdc	0 Vdc power supply	BU Blue
	4	OSSD1	Safety output OSSD channel 1	YE Yellow
	5	Status	Signal output/diagnostic output	GY Grey
	6	Input2	Safety input for daisy-chain channel 2	PK Pink
	7	OSSD2	Safety output OSSD channel 2	PU Purple
	8	EDM / Restart / Serial	EDM K1 K2 feedback / Restart / Daisy-chain loop input	OR Orange

Automatic Start/Restart with EDM

⚠ WARNING

UNINTENDED EQUIPMENT OPERATION

Use manual mode (start/restart interlock activated) if the safety device monitors a guard to protect a hazardous area, where a person can stand in it without being detected, even after passing the guard.

Failure to follow these instructions can result in death, serious injury, or equipment damage.

In "Automatic mode with EDM", the "EDM input" terminal must be connected to 24 Vdc through N.C. K1/K2 contact (in this way monitoring of the external contacts is enabled).

- A safety gate opening (reader/actuator distance > Sar) will deactivate the OSSD outputs.
- The safety gate closure (reader/actuator distance < Sao) will reactivate the OSSD outputs only if the EDM signal is correct.

The following figure shows the connections to perform in order to enable the monitoring of the K1/K2 external contacts.

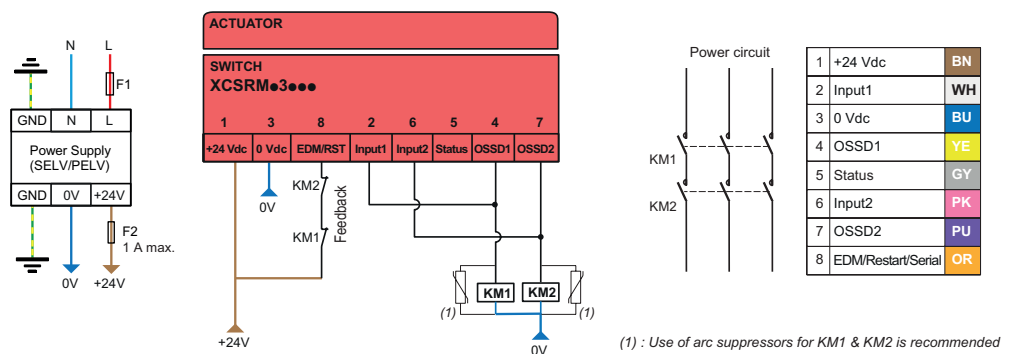

- | | | | |
|-----------------|------------------|----------------|------------------|
| BN Brown | BU Blue | GY Grey | PU Purple |
| WH White | YE Yellow | PK Pink | OR Orange |

Automatic Start/Restart without EDM

When the sensor is configured IN "Automatic without EDM" the monitoring of external K1/K2 contacts is disabled, the "EDM input" must be connected directly to +24 Vdc.

- A safety gate opening (reader/actuator distance > Sar) will deactivate the OSSD outputs.
- At the safety gate closure (reader/actuator distance < Sao) will reactivate the OSSD outputs.

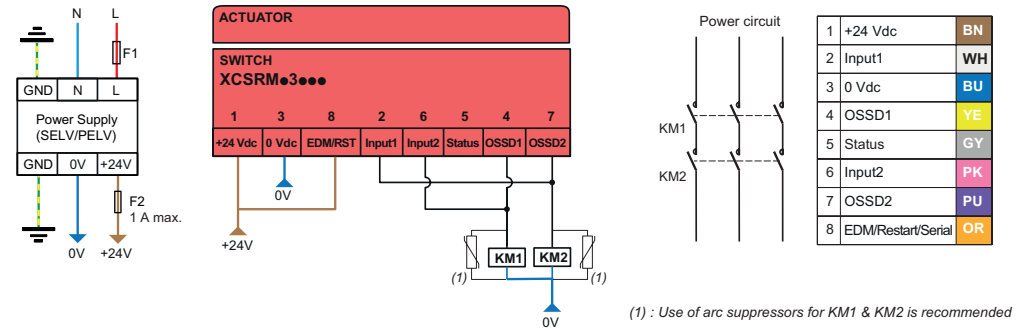

- BN** Brown
- WH** White
- BU** Blue
- YE** Yellow
- GY** Grey
- PK** Pink
- PU** Purple
- OR** Orange

Manual Start/Restart with EDM

XCSRMR RFID switch can operate in MANUAL MODE using an external RESTART command.

- A safety gate opening (reader/actuator distance > Sar) will deactivate the OSSD outputs.
- At the safety gate closure (reader/actuator distance < Sao), to reactivate the OSSD outputs it will be necessary to press the N.O. RESTART button connected to 24 Vdc and release it.

→ The EDM input is only recognized as properly set if, after the sensor activation and after setting the safety inputs, at least one valid start pulse is detected.

→ Use an external normally open push-button, whose temporary closure generates the RESTART command (sequence 0 → 1 → 0).

→ The RESTART command must be connected in series with the K1/K2 control contacts of the external contactors connected to 24 Vdc (pin 8).

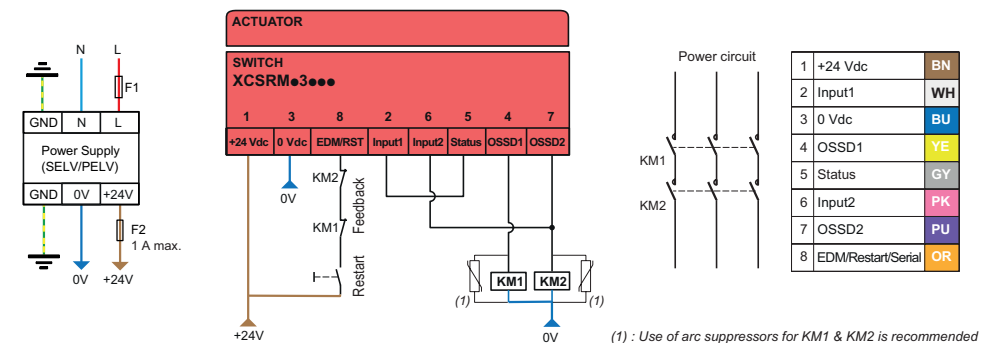

- BN** Brown
- WH** White
- BU** Blue
- YE** Yellow
- GY** Grey
- PK** Pink
- PU** Purple
- OR** Orange

Manual Start/Restart without EDM

XCSRМ RFID switch can operate in MANUAL MODE using an external RESTART command.

- A safety gate opening (reader/actuator distance > Sar) will deactivate the OSSD outputs.
- At the safety gate closure (reader/actuator distance < Sao), to reactivate the OSSD outputs it will be necessary to press the N.O. RESTART button connected to 24 Vdc and release it.

→ Use an external normally open pushbutton, whose temporary closure generates the RESTART command (sequence 0 → 1 → 0).

→ The RESTART command must be connected to 24 Vdc (pin 8).

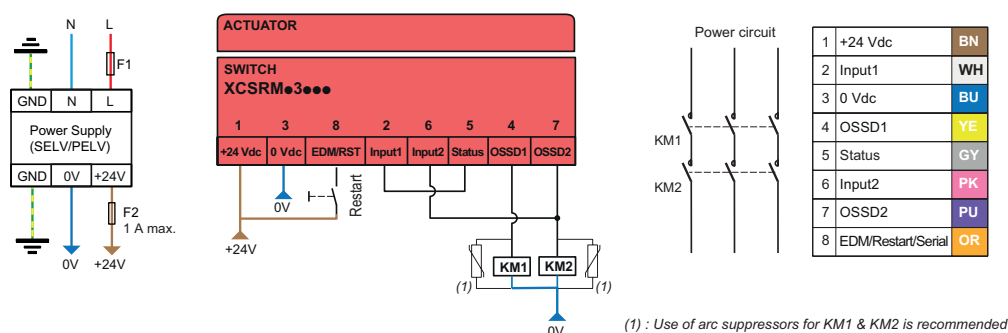

BN Brown
WH White

BU Blue
YE Yellow

GY Grey
PK Pink

PU Purple
OR Orange

Daisy-chain, Connection in Series

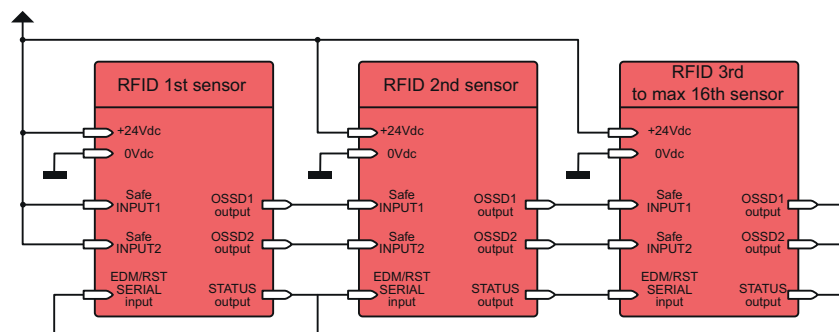
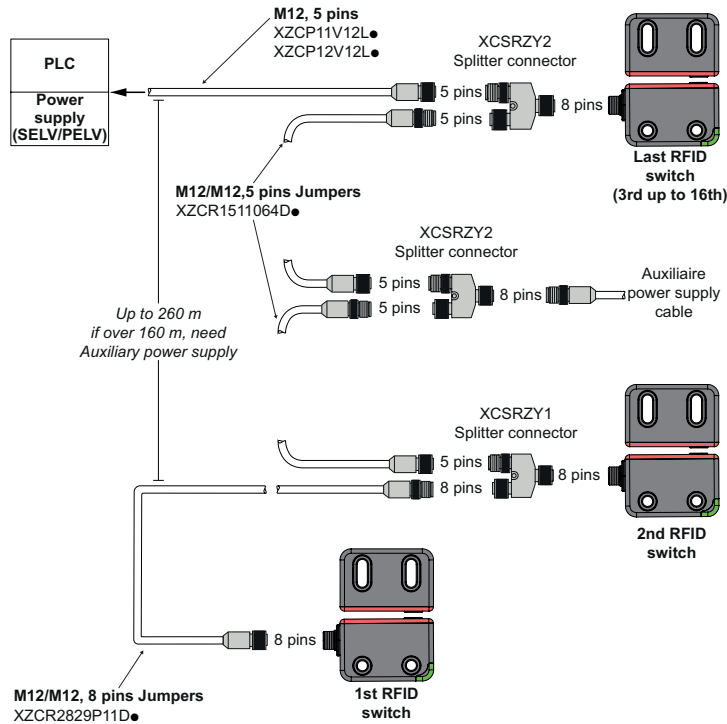

Refer to [Cable References XZCP11V12L••, XZCP12V12L••, or XZCR1111064D••](#), page 61.

Limitations:

Considering only the electrical aspect, the maximum number of switches that can be connected in series depends on different factors: the cable length between each XCSRSM switch, the output current, the input voltage, and the wire cross section.

In the following assumptions: Voltage supply 24 Vdc, Wire cross-section 0.25 mm² (AWG 3), and Output current 200 mA for each output of the last switch (connected to the safety control unit).

<h2 style="margin: 0;">⚠ WARNING</h2>
<p>UNINTENDED EQUIPMENT OPERATION</p> <ul style="list-style-type: none"> The maximum number of XCSRSM•3••• that can be connected in series is limited to 16. The maximum distance between 2 XCSRSM•3••• is 260 m (164 ft.). <p>Failure to follow these instructions can result in death, serious injury, or equipment damage.</p>

Maximum cable length serial connection (max. 260 m / 853 ft)

Depending on the length of the links of the serial chain and connections, it is mandatory to ensure that the power supply is 24 Vdc, as shown in the following table:

Connection Type	Length	Connecting cable cross section	Power supply Voltage	Power supply Auxiliary	Max. Load	Note
Serial connection	≤ 80 m (≤ 262 ft)	0.14 mm ²	24 Vdc	None	-	-
Serial connection	80 m < length ≤ 200 m (262 ft < length ≤ 656 ft)	0.14 mm ²	24 Vdc	Yes	-	Auxiliary power supply cable required
Serial connection	≤ 160 m (≤ 524 ft)	0.25 mm ²	24 Vdc	None	-	-
Serial connection	160 m < length ≤ 260 m (524 ft < length ≤ 853 ft)	0.25 mm ²	24 Vdc	Yes	-	Auxiliary power supply cable required

Assumptions:

- $V_{IN} = 24 \text{ Vdc}$
- Consumption per output (OSSD1 or OSSD2) of the last XCSRМ switch = 0.2 A.
- Cable lengths (L) between XCSRМ switches are the same
- Cable length (L) between the XCSRМ switch and the safety control unit is the same as the cable length between XCSRМ switches
- XCSRМ devices are at the same operating temperature

Y Connector Schematic

Here is Serial mode connection using “Splitter” connectors:

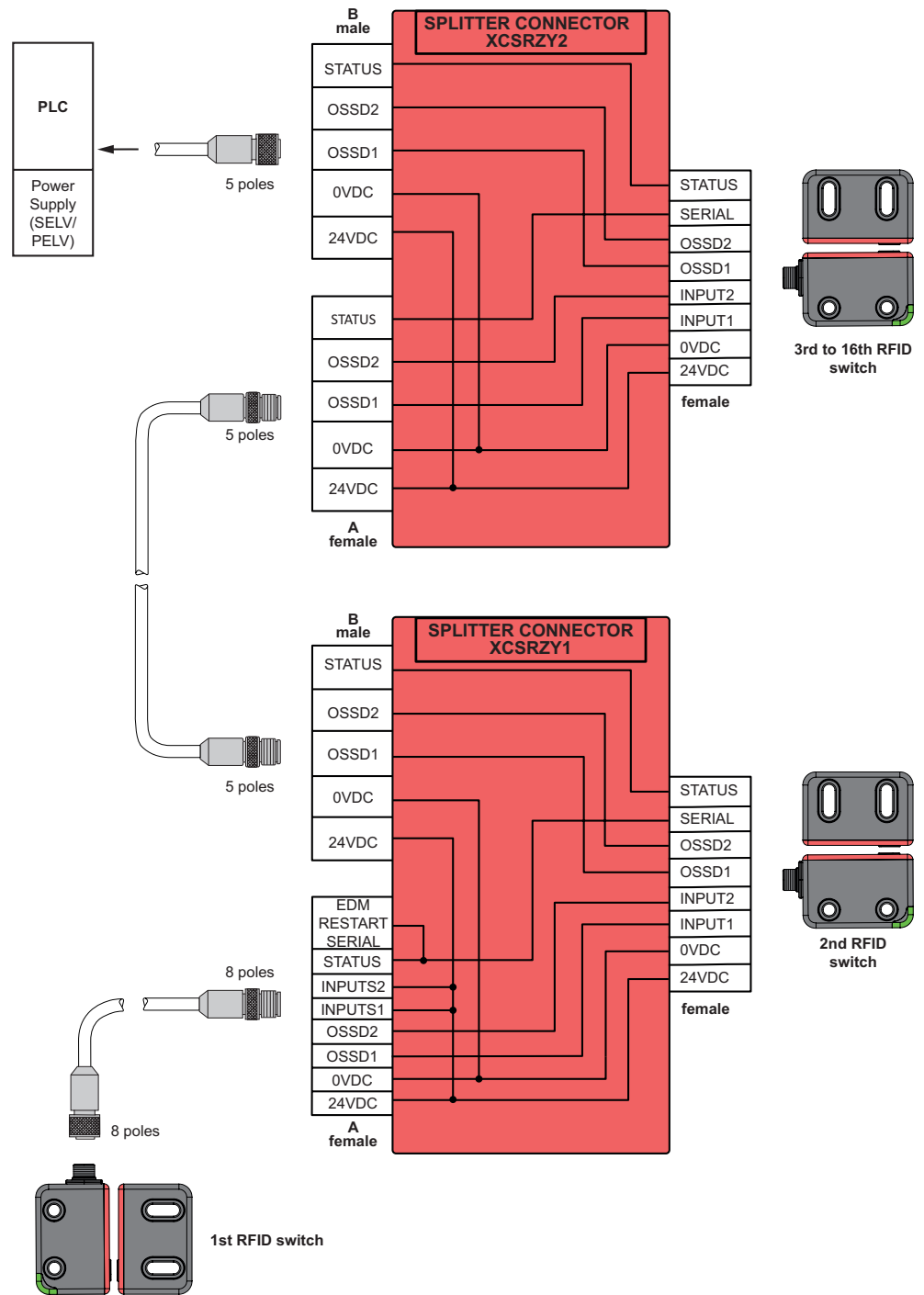

Connection Schematics

When do we use Safety Relays, Controllers or Safety PLCs?

The safety integrity level of a complete safety system can decrease as the number of safety sensors or functions used increases. The use of safety control units like safety controllers or safety PLC can be helpful for keeping the overall system at the right safety integrity level.

Safety control unit can also be justified when additional features are required by the application. The choice between the different ranges of safety control units depends on the number of safety functions and the number of safety sensors used in the application.

This graph is a simplified representation of the common uses of safety control units:

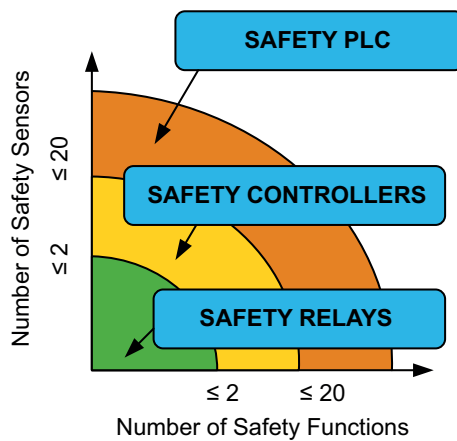

The limit numbers indicated in the graph above are not restrictive and they can vary depending on the applications.

Proof of this is the fact that in daisy-chain connection, the number of XCSR connected in series can be much larger than 2 while a simple safety relay can be used.

Connecting to a Safety Monitoring Device

The wiring from the XCSR RFID Safety Switches to the machine control circuit must be control reliable. The solid-state outputs should be connected only to a control reliable, safety-rated PLC or to a control reliable safety-rated machine system.

Single Model - Connecting with a Safety Controller

This figure describes the connection of a XCSRC•0... single model with a Safety controller:

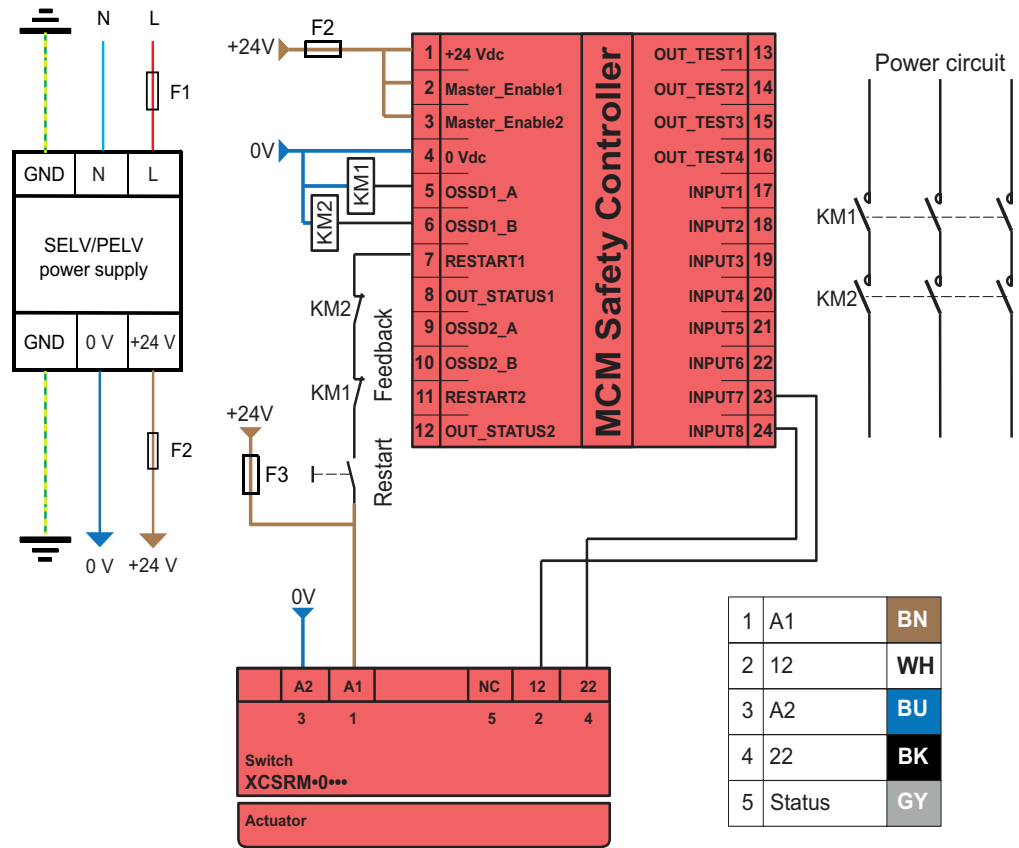

BN Brown
WH White

BU Blue
BK Black

GY Grey

Refer to [Cable References XZCP11V12L••](#) or [XZCP12V12L••](#), page 61

NOTICE

INOPERABLE EQUIPMENT

The maximum cable length for EDM/restart feedback loop and any other connections is 30 m (98.42 ft.).

Failure to follow these instructions can result in equipment damage.

⚠ WARNING

UNINTENDED EQUIPMENT OPERATION

The KM1 and KM2 contactors must have [force-guided contacts](#), page 19.

Failure to follow these instructions can result in death, serious injury, or equipment damage.

Single Model - Connecting with a XPSUAK Module

This figure describes the connection of single model XCSR0•0••• with an XPSUAK module, with EDM and manual start with monitoring of the start button:

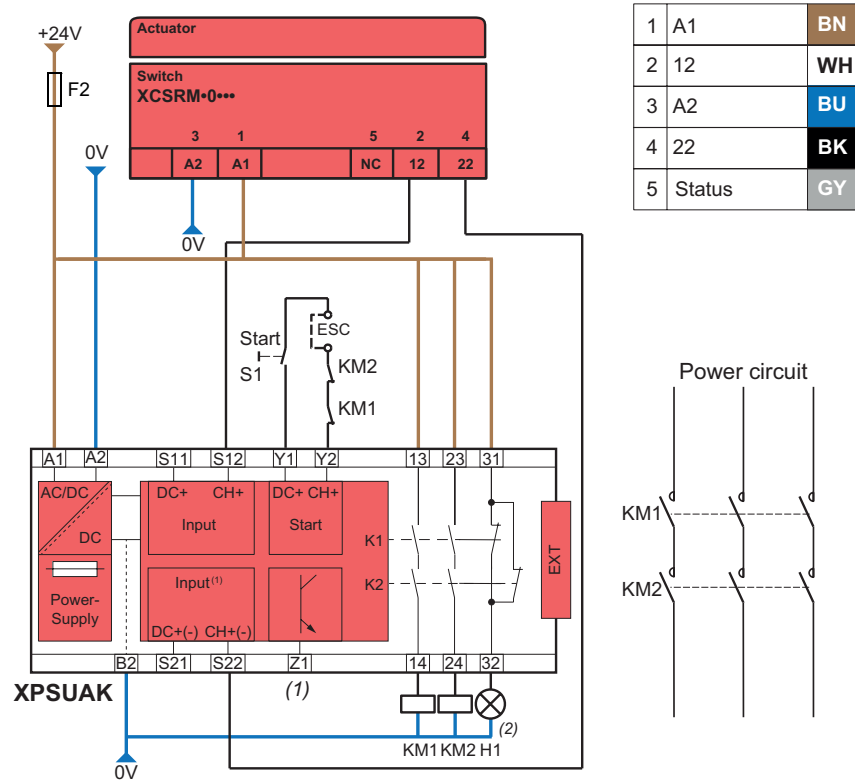

- (1) Pulsed output for diagnostics
 - (2) XCSR0 RFID Safety Switches indicator light deactivated
- ESC** External Start Conditions

BN Brown **BU** Blue **GY** Grey
WH White **BK** Black

Refer to [Cable References XZCP11V12L••](#) or [XZCP12V12L••](#), page 61.

Automatic start is possible by removing the start button in the schematic above (short circuit instead) and by connecting directly **S13** to **S14** (electrical jumper between S13 and S14).

NOTICE

INOPERABLE EQUIPMENT

The maximum cable length for EDM/restart feedback loop and any other connections is 30 m (98.42 ft.).

Failure to follow these instructions can result in equipment damage.

⚠ WARNING

UNINTENDED EQUIPMENT OPERATION

The KM1 and KM2 contactors must have [force-guided contacts](#), page 19.

Failure to follow these instructions can result in death, serious injury, or equipment damage.

Advanced Model - Daisy-Chain connection with a Safety Controller

This figure describes the connection of a XCSR00... single model with an Safety controller:

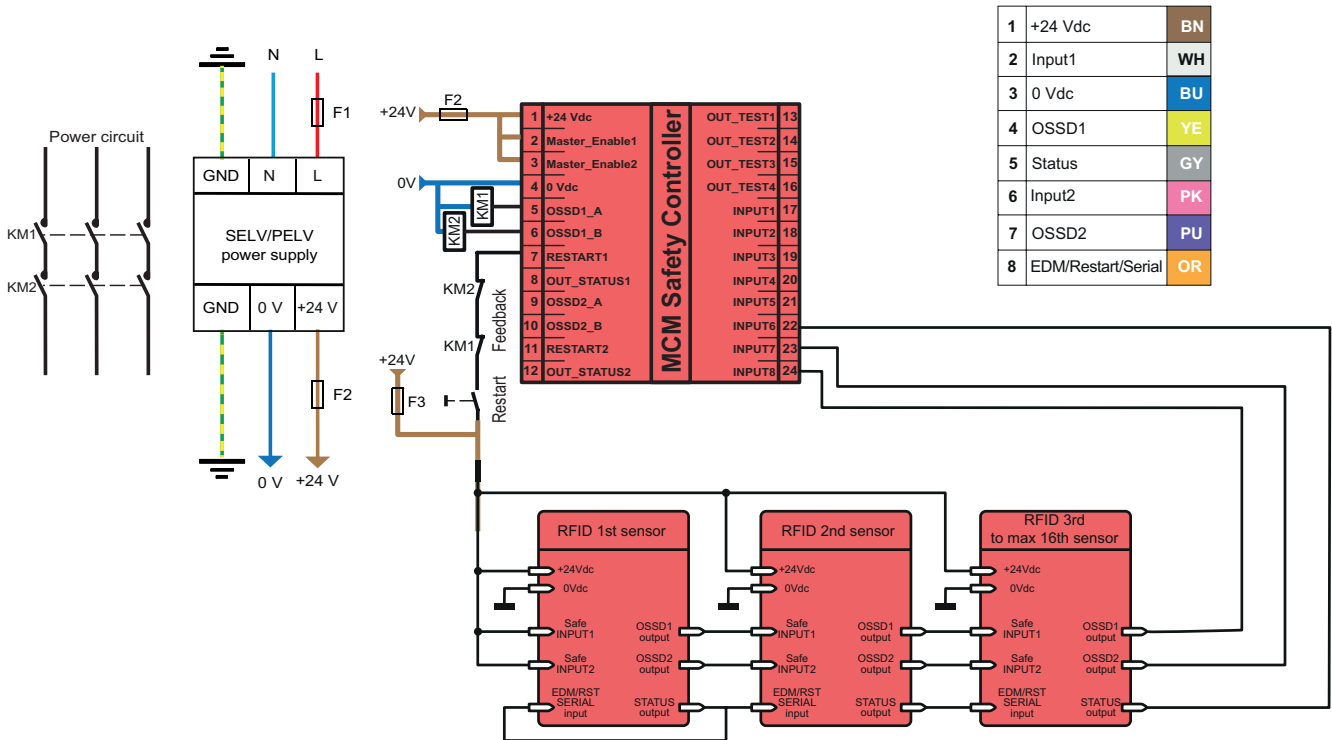

- BN Brown BU Blue GY Grey PU Purple
- WH White YE Yellow PK Pink OR Orange

Refer to [Y connectors XCSRZY1 and XCSRZY2, page 60](#) and [M12-8 pin jumper XZCR2829P11, page 62](#).

Automatic start is possible by removing the start button in the schematic above (short circuit instead) and by connecting directly **S13** to **S14** (electrical jumper between S13 and S14).

NOTICE

INOPERABLE EQUIPMENT

The maximum cable length for EDM/restart feedback loop and any other connections is 30 m (98.42 ft.).

Failure to follow these instructions can result in equipment damage.

⚠ WARNING

UNINTENDED EQUIPMENT OPERATION

The KM1 and KM2 contactors must have [force-guided contacts, page 19](#).

Failure to follow these instructions can result in death, serious injury, or equipment damage.

Advanced model - Series Connecting with a XPSUAF Module

This figure describes the series connection of five XCSR•2••• daisy-chain models with an XPSUAF module, with EDM and monitored manual start:

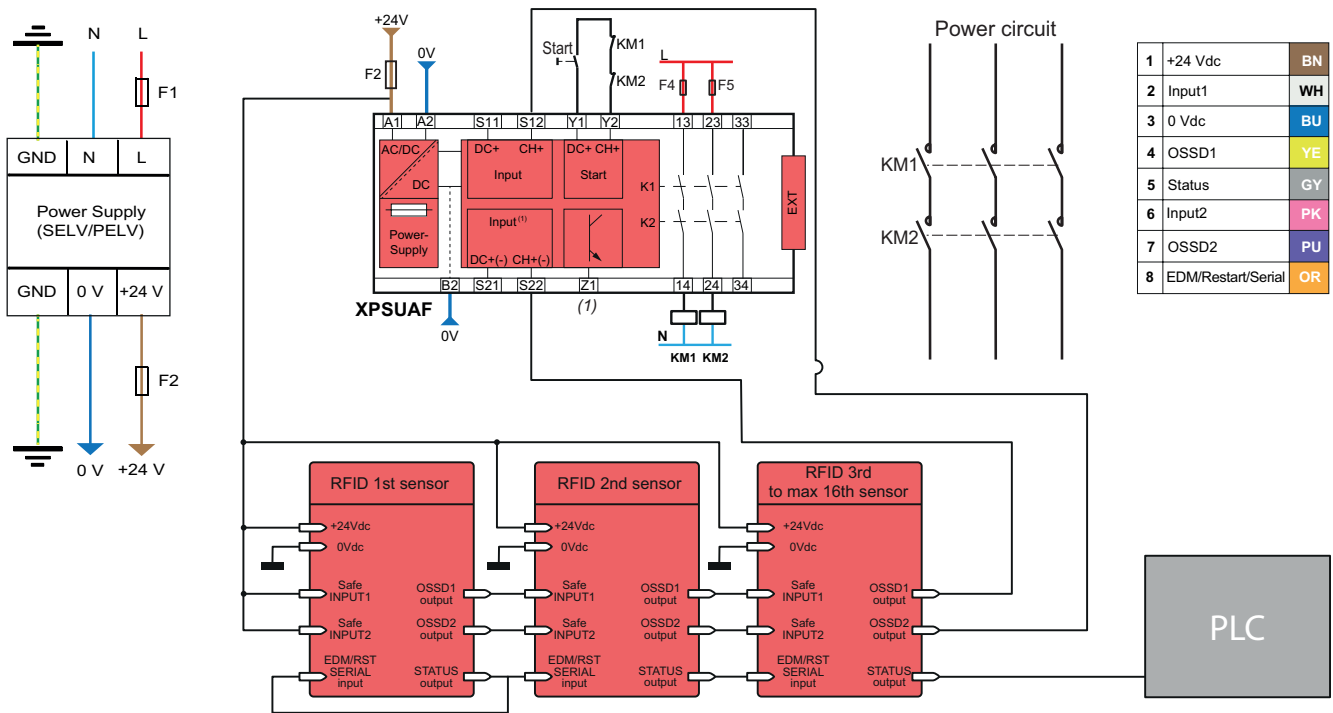

(1) Pulsed output for diagnostics

- BN** Brown **BU** Blue **GY** Grey **PU** Purple
- WH** White **YE** Yellow **PK** Pink **OR** Orange

Refer to [Y connectors XCSRZY1 and XCSRZY2, page 60](#) and [M12-8 pin jumper XZCR2829P11, page 62](#).

NOTICE

INOPERABLE EQUIPMENT

The maximum cable length for EDM/restart feedback loop and any other connections is 30 m (98.42 ft.).

Failure to follow these instructions can result in equipment damage.

⚠ WARNING

UNINTENDED EQUIPMENT OPERATION

The KM1 and KM2 contactors must have [force-guided contacts, page 19](#).

Failure to follow these instructions can result in death, serious injury, or equipment damage.

Diagnostic & Maintenance

Diagnostic by HMI

This table describes the operating and output states with LED meanings and output states of the XCSRМ RFID Safety Switch:

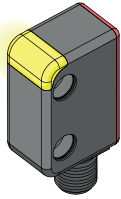
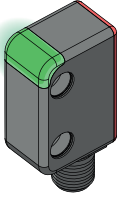
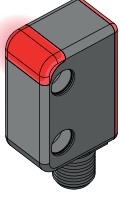
	Configured mode (power up)		Led Color	Blinking
	Single sensor with EDM in AUTO mode		Yellow	2
	Single sensor without EDM in AUTO mode		Yellow	3
	Single sensor in MANUAL mode		Yellow	4
	First sensor of serial connection		Yellow	5
	Sensor of serial connection		Yellow	6
	Sensor status (normal operation)	Led Color	Meaning	
	BREAK	Red	OSSD outputs LOW	
	GUARD	Green	OSSD outputs HIGH	
	RESTART	Yellow	Waiting for Restart	
	GUARD / INPUT OFF	Green / Red - Blinking	One or more sensors in the chain is in BREAK state	
	PROGRAMMING	Blinking Green	Actuator programming (Pairing)	
	CONFIG	Blinking Yellow	Configuration type	
	FAIL	Blinking Red	Error condition	
	Error (diagnostic)	Led Color	Blinking	Action to take
	OSSD outputs error	Red	1	Check OSSD connections (4, 7)
	Safety input incongruency	Red	2	Check sensor series connections (Input 2, 6 /OSSD 4, 7)
	EDM error	Red	3	Check EDM connections (8)
	Over voltage detected	Red	4	Check connections / Replace the product
	Internal error	Red	5	Replace the product
	Pairing procedure counter overflow	Red	6	Maximum number of automatic pairing procedures reached. Use wiring procedure. In case of Single model, replace the sensor.
	Incorrect wire Configuration	Red	7	Check connections
	Antenna overvoltage detected	Red	10	Replace the product

New Actuator Pairing During Maintenance

NOTICE

INOPERABLE EQUIPMENT

- For a new pairing operation, the actuator must be placed and maintained at a distance \leq Sao, without misalignment with the switch, until the end of the pairing operation.
- During an actuator pairing process, do not place other actuator in the detection area.

Failure to follow these instructions can result in equipment damage.

The possibility to pair up to two new blank transponders, provides flexibility in case of actuator damages. However, the integrity of the safety system is reduced due to the availability of actuators as spare parts which could increase the possibilities of tampering.

⚠ WARNING

UNINTENDED EQUIPMENT OPERATION

Strict procedures must be implemented in order to control the access to these blank transponders and to their use.

Failure to follow these instructions can result in death, serious injury, or equipment damage.

The pair-able switch can be only programmed (by the user during the start-up phase) using a XCSRK1BU pair-able actuator.

It is possible to pair the new RFID actuator in two ways:

Automatic Pairing Procedure

For start-up automatic pairing procedure, it is necessary to proceed as follows:

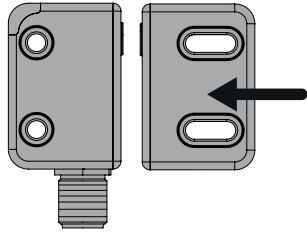
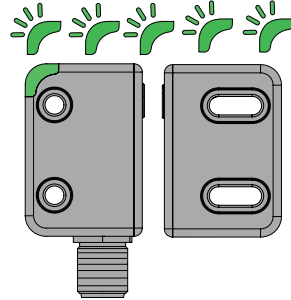
Step	Action	Details
1	Place the actuator in front of the switch (at a distance < 2mm).	 <p>Initial position</p>
2	Power on the RFID switch. The switch reads the actuator code and starts the pairing process. The code memorization (condition B) will not start if the switch and the actuator were previously paired.	 <p>Switched on, pairing process (fast blinking)</p>

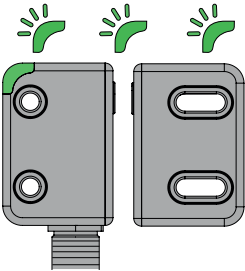
Step	Action	Details
2	The procedure will be completed after 5 seconds.	 <p>Paired, waiting for a restart (slow blinking)</p>

NOTE:

- This procedure will take about 5 seconds. The above procedure can only take place **3 times**, after which it reverts to the through wire pairing procedure for advanced unlimited pairing version, XCSRMU3••••.
- All the conditions are signaled in real-time by the multicolor LED based on the RFID switch.

Pairing through Wire Procedure

This configuration is valid for advanced unlimited pairing version, XCSRMU3•••• only.

For pairing through wire procedure, the switch must be wired following the configuration in the section [Configuration for Allocating a new ID to the sensor, page 53](#).

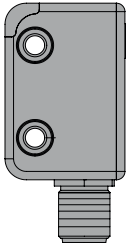
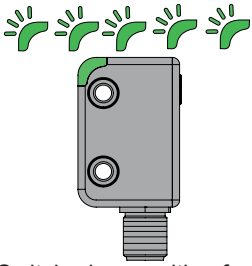
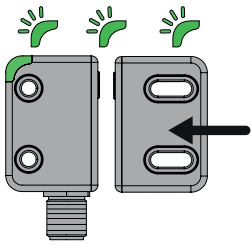
Step	Action	Details
1	Power on the XCSR RFID switch.	 <p>Waiting for power on</p>
	After power on, the switch will be ready for pairing with the actuator	 <p>Switched on, waiting for programming (fast blinking)</p>
2	Approach actuator to switch, when the actuator is approaching the RFID switch at a distance ≤ 2 mm (0.078 in), the switch is programmed after 5 seconds	 <p>Programmed, waiting for a restart (slow blinking)</p>

All the conditions are signaled in real-time by the multicolor LED based on the RFID sensor.

Configuration for Allocating a new ID to the sensor

For the advanced version (XCSRMU3****), the switch can be programmed with a new ID. This function will be realized by the user during the start-up phase (→ PAIRING PROCEDURE), configuring the switch as in the following diagram.

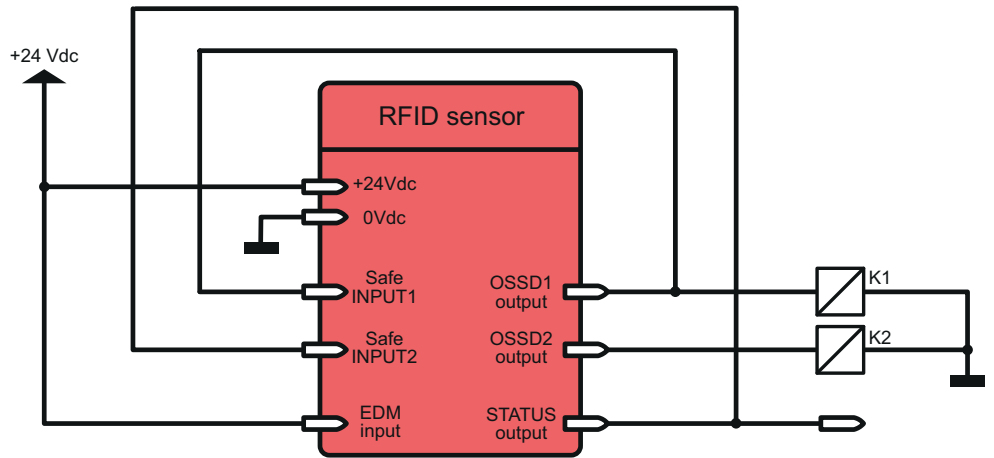

Signal / (pin)	Colors
Input 1 (2)	WH: White
Input 2 (6)	PK: Pink
EDM Input / (8)	OR: Orange

Connected to / (pin)	Colors
OSSD1 / (4)	YE: Yellow
Status / (5)	GY: Grey
24 Vdc / (1)	BN: Brown

Diagnostic of Series Connection by Pulsed State Output

Status Output Transmission Protocol

A system Status output is available in the RFID switch for diagnostics. the output signal is a 24 Vdc square waveform that corresponds to the status of the switch chain.

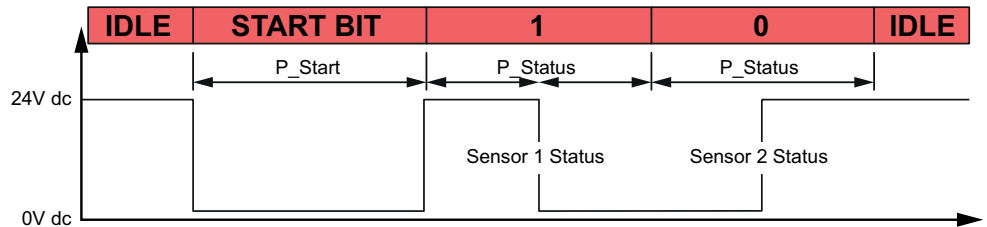

NOTE: The timing requirements for data transmission are not critical to the safety of the device, as “Status” is not a safety. The following table shows the timing requirements.

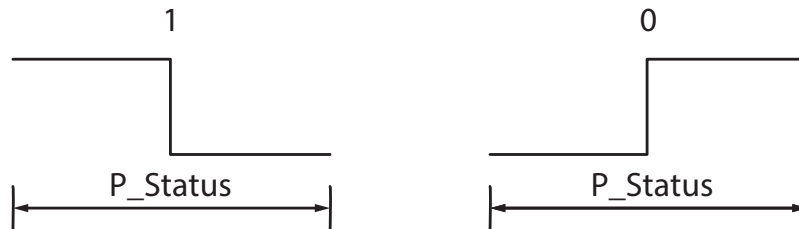

Time requirement	Description	Bit Timing (ms)
IDLE	High level	Continuous
P_Start	Low level	150 ± 10
P_Status center Bit 0	Rise edge	150 ± 10
P_Status center Bit 1	Fall edge	150 ± 10
Intercharacter	High level	≥ 5000
Delay retransmission	High level	150 ± 10

Technical Characteristics

Overview

This chapter describes the technical characteristics of the XCSRМ RFID Safety Switch.

XCSRМ RFID Safety Switch Specifications

Conformity/Approvals

This table provides the standards and approvals:

Conforming to standards	EN/ISO 14119, EN/IEC 60947-5-2, EN/IEC 60947-5-3, EN/ETSI 301 489-1, EN/ETSI 300 330 IEC 61508 (SIL 3), IEC 62061 (SILCL 3), ISO 13849-1 (PLe–Cat.4) UL 508, CSA C22.2, CFR 47 FCC 15, RSS GEN, RSS 210
Approvals	CE, cULus (The safety function of this device has been evaluated by TÜV Sud, not by UL), TÜV, FCC (under application)

Environmental Specifications

This table provides the environmental specifications:

Environmental characteristics		Description
Ambient air temperature	For operation	-25...+70 °C (-13...+158 °F) Humidity < 95% - without condensation
	For storage	-25...+70 °C w Humidity < 95% - without condensation
Degree of protection	M12 0.15 m cable models	IP65, and IP67 conforming with EN/IEC 60529 IP69K for enclosure conforming with DIN 40050
Resistance to shocks and vibrations	–	In accordance with EN/IEC 60947-5-3: Shocks, conforming with EN/IEC 60068-2-27: 30 gn (impulse duration 11 ms) Vibration, conforming with EN/IEC 60068-2-6: ± 1 mm amplitude (10...55 Hz)
Materials	–	Housing: Nylon Black color on cover, Red color on detection face: RAL 3000
Environmental chemicals		
Chemical resistance	Aliphatic hydrocarbons	Resistant
	Alcohols	
	Detergents and cleansers	
	Detergents and cleansers containing alkali products	
	Alkaline (non-chlorinated) cleaning agents	
	Acid cleaning agents	
	Ecolab® certificate	
Environmental resistance	Humidity	Resistant
	Weathering (sun, water)	

Characteristic Times

This table provides the characteristic times:

Characteristic times	Unit	Value	Description
Response time	ms	$T_t \leq 250\text{ms}$	Refer to Definition of Characteristic Times , page 10.
Risk time	ms	$T_r < 55\text{ ms}$ (+ 12 ms per additional switch in Daisy-Chain configuration)	
First-up time	s	$T_{ON} < 1\text{ s}$	
Pairing mode time	s	$T_{PM} = 20\text{ s}$	
Safety inputs inconsistency time	ms	$T_{IT} < 500\text{ ms}$	
Switching frequency	Hz	0.5 Hz maximum	

Typical Operating Distances (Face to Face Mounting)

This table provides the typical operating distances:

Characteristic times	Unit	Value	Description
Assured operating sensing distance (Sao)	mm	$S_{ao} = 10\text{ mm } (0.39\text{ in})$	FD1 Functional Direction along longitudinal axis, page 32.
Typical release sensing distance	mm	$12\text{ mm } (*) (0.47\text{ in})$	
Assured release sensing distance (Sar)	mm	$S_{ar} = 25\text{ mm } (0.98\text{ in})$	
Repeat accuracy	–	$\leq 1.2\% \times S_r$	
Typical hysteresis	–	$H_r < 2.4\text{ mm } (20\% \times S_r), S_r = 12\text{ mm } (0.47\text{ in})$	

(*) Ambient temperature, on non-magnetic support, without misalignment between the actuator and the switch.

Electrical Characteristics

The given table provides the electrical characteristics:

Electrical characteristics	Unit	Description
Power supply	V	24 Vdc -20% +20% The power supply must meet requirements of IEC 60204-1 relative to SELV/ PELV power supply.
Maximum current consumption (no load)	mA	30 mA
Rated impulse withstand voltage	kV	Uimp = 1 kV
EMC immunity withstands	–	Conforming EN/IEC 60947-5-3, EN/IEC 61326-3-1, and EN/ETSI 301 489-1
Safety outputs (OSSD)	–	Single and daisy-chain: <ul style="list-style-type: none"> • Maximum 300 mA per output at 24 Vdc • Drop out voltage < 3.5 Vdc • Maximum load capacitance 300 nF under 24 Vdc • Switching capacity: DC12: Ue = 24 Vdc - Ie = 300 mA DC12: Resistive load Short Circuit protection conforming to EN/IEC 60947-5-3
Safety-related inputs (advanced model only)	–	Two DC digital positive inputs 24 Vdc -20% +20% Current consumption < 5 mA
Status output	–	Maximum 100 mA at 24 Vdc
Maximum XCSRМ RFID Safety Switches connectable in series	–	< 16 XCSRМ•3••• Advanced model (refer to Series Connections, page 38)
Signals	–	One triple color LED
Connections	–	Single Model XCSRМ•0•••: 5-pin M12 connector, 2 m /5 m /10 m (6.56 ft /16.40 ft /32.80 ft) cables, 100 mm (3.93 in) cable + M12 connector Advanced Model XCSRМ•3•••: 8-pin M12 connector, 100 mm (3.93 in) cable + M12 connector Refer to Electrical Connections, page 37 .
Protection against electric shocks	–	Class III as per EN/IEC 61140

Radio-Emission Characteristics

The given table provides the radio-emission characteristics:

Radio-emission characteristics	Unit	Description
Operating frequency band	kHz	122...128
Maximum radiated magnetic field	dBµA/m	-7.77 dBµA/m at 10 m, according to EN/ETSI 300 330

Safety Related Data

General Description This table provides safety related data for the XCSRМ RFID Safety Switches:

Mission Time (TM) EN/ISO 13849-1	PFH _D EN/ISO 13949-1 and EN/IEC 62061
20 years	2.62 x 10 ⁻⁹ Per reader

For safety related data definitions, refer to the [Glossary, page 63](#).

Dimensions

Dimensions of the product

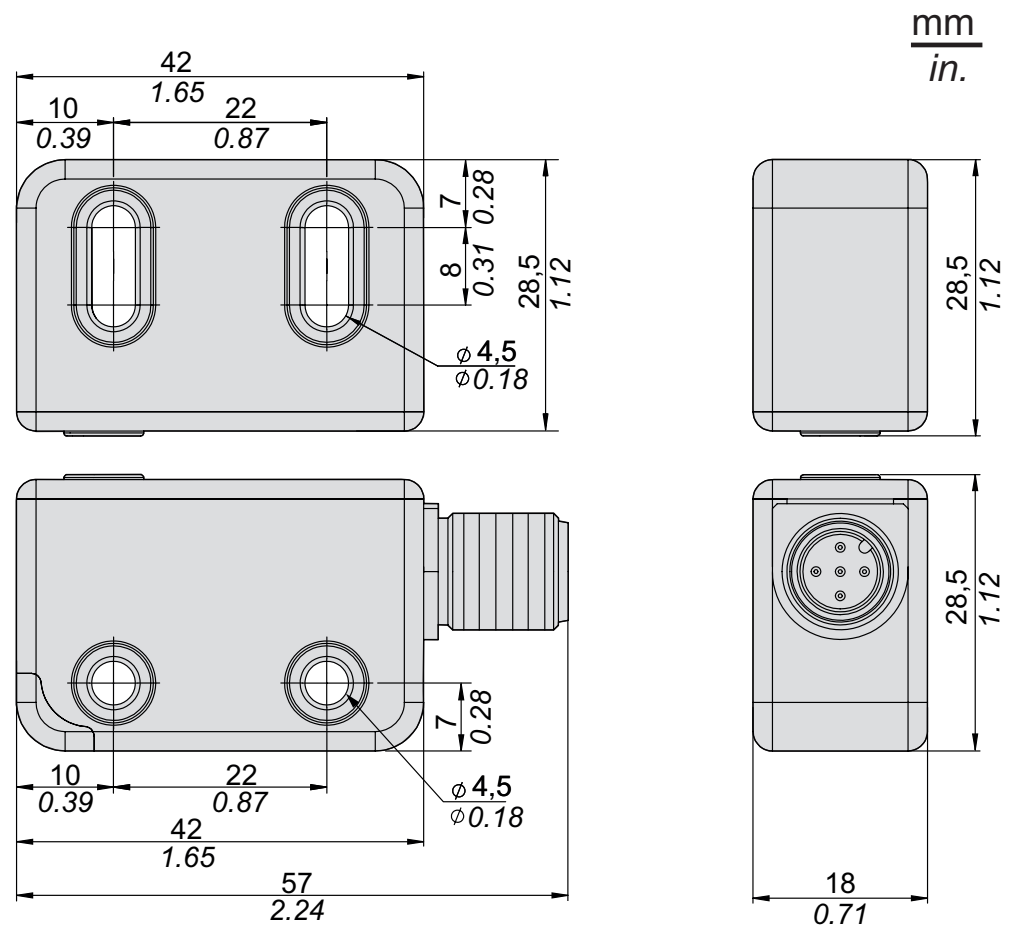

Dimensions of Accessories

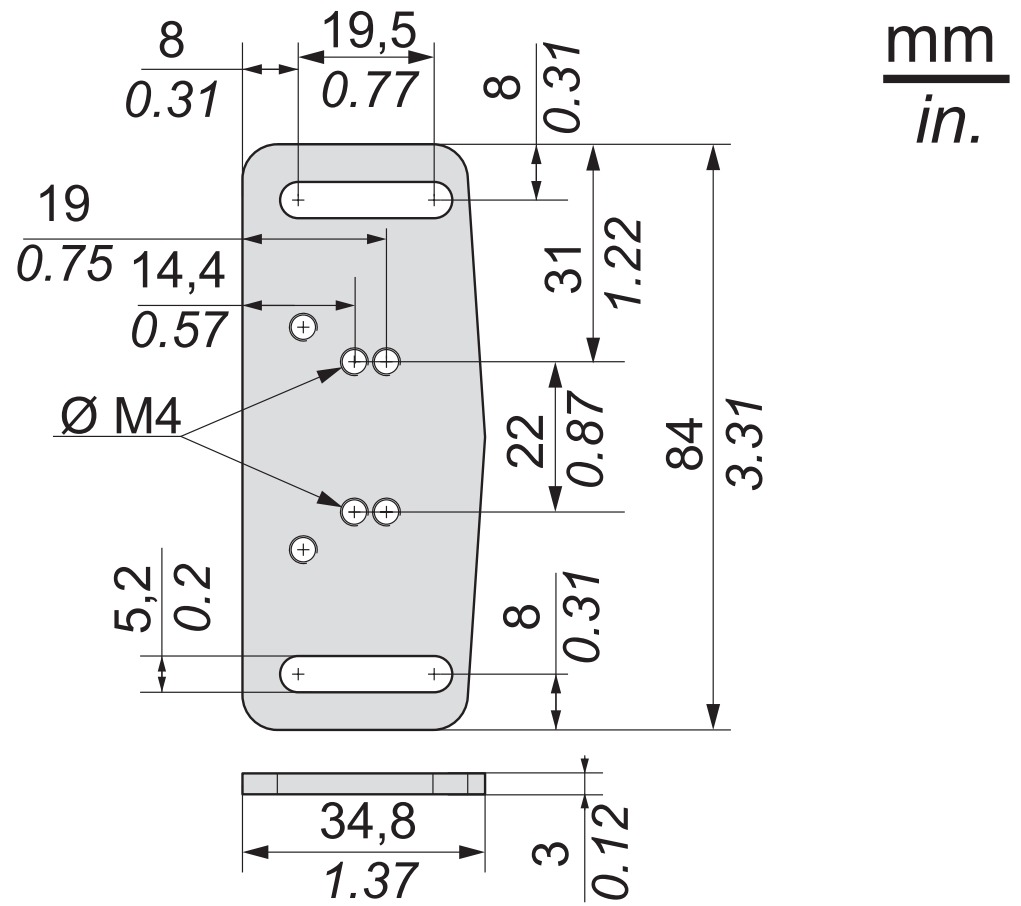

XCSRZSTK1

Accessories

Mounting Accessories

This table describes M4 one-way screw that should be used to mount the XCSRМ RFID Safety Switches:

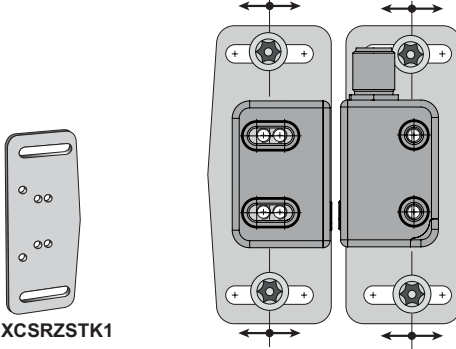
Reference	Description	
XCSRZSTK1 ⁽¹⁾	Mounting plate for both switch and actuator.	 <p>XCSRZSTK1</p> <p>NOTE:</p> <ul style="list-style-type: none"> • To order separately • For fixing the mounting support on the machine, the use of M5 tamper-proof screws is strongly recommended
<p>(1) For fixing the mounting support on the machine, the use of M5 tamper-proof screws is strongly recommended.</p>		

Actuator

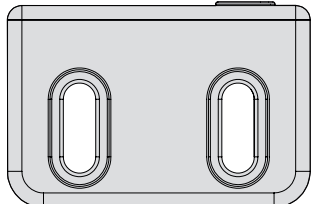
Reference	Description	
XCSRK1BU	Unlimited pairing actuator	
XCSRK1BL	Generic coded actuator	

Y Connector

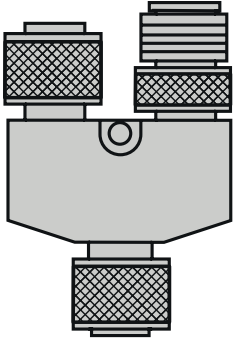
Reference	Description	
XCSRZY1	Splitter connector M12, 8-8-5 poles, Female-Male-Female, first in daisy-chain	
XCSRZY2	Splitter connector M12, 8-5-5 poles, Female-Male-Female, following in daisy chain	

Cables

This table describes the 5-pin cables for use with single (XCSRМ•0•••) models and for the connection between a safety control unit and the last switch of a daisy-chain (XCSRМ•3•••):

Cables (pre-wired 5 pins)	Description	Length
XZCP11V12L2	Connector M12 - Female - Straight - 5 poles - PUR - pre-wired 0.34 mm ² (AWG22). Unshielded cable	2 m (6.56 ft)
XZCP11V12L5		5 m (16.4 ft)
XZCP11V12L10		10 m (32.8 ft)
XZCP11V12L20		20 m (65.6 ft)
XZCP12V12L2	Connector M12 - Female - 90° - 5 poles - PUR - pre-wired 0.34 mm ² (AWG22). Unshielded cable	2 m (6.56 ft)
XZCP12V12L5		5 m (16.4 ft)
XZCP12V12L10		10 m (32.8 ft)
XZCP12V12L20		20 m (65.6 ft)
XZCC12FDM50B	Connector M12 - Female - Straight - 5 poles with screw terminals - cable gland - Metal clamping ring	-
XZCC12FCM50B	Connector M12 - Female - 90° - 5 poles with screw terminals - cable gland - Metal clamping ring	-

This table describes the jumper cables for direct series connection of Y connectors (XCSRМ•3••• in Daisy chain connection):

Cables (jumpers 5 pins)	Description	Length
XZCR1511064D1	2 straight M12 - Female/Male- PUR - 5 poles 0.34 mm ² (AWG22). Unshielded cable	1 m (0.98 ft)
XZCR1511064D2		2 m (9.84 ft)
XZCR1511064D5		5 m (16.4 ft)
XZCR1511064D10		10 m (32.8 ft)

M12 5-pins connector description:

Pin number	Wire color	Connector
1	Brown	
2	White	
3	Blue	
4	Black	
5	Gray	

This table describes the 8-pin cables for XCSRМ•3••• in Standalone:

Cables (pre-wired 8 pins)	Description	Description
XZCP29P12L2	Connector M12 - Female - Straight - 8 poles - PUR - pre-wired 0.34 mm ² (AWG22). Unshielded cable	2 m (6.56 ft)
XZCP29P12L5		5 m (16.4 ft)
XZCP29P12L10		10 m (32.8 ft)
XZCP29P12L20		20 m (65.6 ft)
XZCP53P12L2	Connector M12 - Female - 90° - 8 poles - PUR - pre-wired 0.34 mm ² (AWG22). Unshielded cable	2 m (6.56 ft)
XZCP53P12L5		5 m (16.4 ft)
XZCP53P12L10		10 m (32.8 ft)
XZCP53P12L20		20 m (65.6 ft)
XZCC12FDM80B	Connector M12 - Female - Straight - 8 poles with screw terminals - cable gland - Metal clamping ring	-
XZCC12FCM80B	Connector M12 - Female - 90° - 8 poles with screw terminals - cable gland - Metal clamping ring	-

This table describes the jumper cables for direct series connection from XCSRМ•3••• to Y connectors:

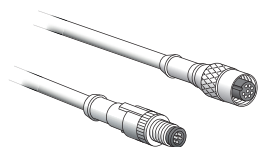
Reference	Description	
XZCR2829P11D2	Jumper straight M12 8-pin Male, straight M12 8-pin Female, PUR cable 2m (6.56 ft)	
XZCR2829P11D5	Jumper straight M12 8-pin Male, straight M12 8-pin Female, PUR cable 5m (16.40 ft)	
XZCR2829P11D10	Jumper straight M12 8-pin Male, straight M12 8-pin Female, PUR cable 10m (32.80 ft)	
XZCR2829P11D20	Jumper straight M12 8-pin Male, straight M12 8-pin Female, PUR cable 20m (65.61 ft)	

M12 8-pins connector description:

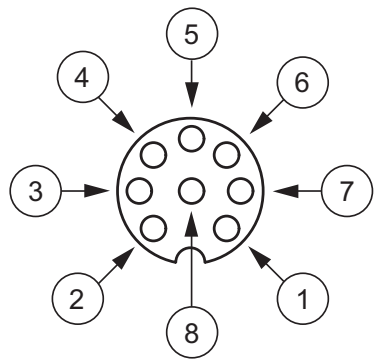
Pin number	Wire color	Connector
1	Brown	
2	White	
3	Blue	
4	Black	
5	Gray	
6	Pink	
7	Purple	
8	Orange	

Glossary

A

ANSI

American National Standards Institute. The administrator and coordinator of the U.S. private sector standardization system.

AWG

(American wire gauge) The standard that specifies wire section sizes in North America.

C

Category (Cat.)

Describe the safety-related parts of control systems performance in relation to their ability to resist to failures and resulting behavior in case of failure. Five categories are defined depending on design architectures.

Control-reliable

The device, system, or interface shall be designed, constructed, and installed such that a single component failure within the device, interface, or system shall not prevent normal stopping action from taking place, but shall prevent a successive machine cycle (ANSI B11.191).

E

EDM/MPCE (External Device Monitoring/Machine Primary Control Element Monitoring)

A means by which the XCSR RFID switch monitors the state of external control devices.

EMC

(ElectroMagnetic Compatibility)

I

IEC

(International Electrotechnical Commission) A non-profit and non-governmental international standards organization that prepares and publishes international standards for electrical, electronic, and related technologies.

IP 67

(ingress protection) The protection classification according to IEC 60529. IP 67 modules are protected against ingress of dust, contact, and water up to an immersion depth of 1 m.

IP69K

Protection classification according to DIN40050 relative to high pressure cleaning test.

M

Mission Time

Period of time covering the intended use of a safety related system.

O**Off state**

The state in which the output circuit is interrupted (open) and does not allow current to flow.

On state

The state in which the output circuit is complete (closed) and allows the flow of current.

Output Safety Switching Device (OSSD)

The component of the XCSR RFID switch connected to the machine control system which, when the guard door is open, responds by going to Off state. This is also known as a safety output.

P**Performance level (PL)**

Ability of safety-related parts of control systems (SRP/CS) to perform a safety function in order to achieve the required risk reduction.

Probability of Dangerous Failure per Hour

(PFH_D) Average probability of dangerous failure per hour for high demand mode of operation.

R**Response times:**

Refer to [Definition of Characteristic Times, page 10](#).

S**Safety Integrated Level (SIL)**

The failure mode evaluation based on the risk assessment in accordance with IEC 61508. Estimation of the required SIL is performed for each safety-related control function (SRCF) and represent the levels that the control-command must respect according to the known risk factors associated with the installation. Level 3 is the highest and Level 1 the lowest level.

Sao (Assured Operating Sensing Distance)

S_{ao} is the distance from the sensing face within which the presence of the specified target is correctly detected under all specified environmental conditions and manufacturing tolerances

Sar (Assured Release Sensing Distance)

S_{ar} is the distance from the sensing face beyond which the absence of the specified target is correctly detected under all specified environmental conditions and manufacturing tolerances

SELV

(*safety extra low voltage*) A system that follows IEC 61140 guidelines for power supplies is protected in such a way that voltage between any 2 accessible parts (or between 1 accessible part and the PE terminal for class 1 equipment) does not exceed a specified value under normal conditions or under inoperable conditions.

www.telemecaniquesensors.com

The information provided in this catalogue contains description of products sold by TMSS France, its subsidiaries and other affiliated companies ('Offer') with technical specifications and technical characteristics of the performance of the corresponding Offer.

The content of this document is subject to revision at any time without notice due to continued progress in methodology, design and manufacturing.

To the extent permitted by applicable law, no responsibility or liability is assumed by TMSS France, its subsidiaries and other affiliated companies for any type of damage arising out of or in connexion with (a) informational content of this catalogue not conforming with or exceeding the technical specifications, or (b) any error contained in this catalogue, or (c) any use, decision, act or omission made or taken on the basis of or in reliance on any information contained or referred to in this catalogue.

NEITHER TMSS FRANCE, ITS SUBSIDIARIES, NOR ITS OTHER AFFILIATES, AS THE CASE MAYBE, MAKE NO WARRANTY OR REPRESENTATION OF ANY KIND, WHETHER EXPRESS OR IMPLIED, AS TO WHETHER THIS CATALOGUE OR ANY INFORMATION CONTAINED THEREIN SUCH AS PRODUCTS WILL MEET REQUIREMENTS, EXPECTATIONS OR PURPOSE OF ANY PERSON MAKING USE THEREOF.

Telemecanique™ Sensors is a trademark of Schneider Electric Industries SAS used under license by TMSS France. Any other brands or trademarks referred to in this catalogue are property of TMSS France or, as the case may be, of its subsidiaries or other affiliated companies. All other brands are trademarks of their respective owners.

This catalogue and its content are protected under applicable copyright laws and provided for informative use only.

No part of this catalogue may be reproduced or transmitted in any form or by any means (electronic, mechanical, photocopying, recording, or otherwise), for any purpose, without the prior written permission of TMSS France. Copyright, intellectual, and all other proprietary rights in the content of this catalogue (including but not limited to audio, video, text, and photographs) rests with TMSS France, its subsidiaries, and other affiliated companies or its licensors. All rights in such content not expressly granted herein are reserved. No rights of any kind are licensed or assigned or shall otherwise pass to persons accessing this information.

As standards, specifications and design change from time to time, please ask for confirmation of the information given in this publication.

©2025, TMSS France, All Rights Reserved.

TMSS France SAS

Share capital: 366 931 214 €
Tour Eqho, 2 avenue Gambetta
92400 Courbevoie – France
908 125 255 RCS Nanterre

March 2025 - V0.1

TESEUG000071EN